INFORMATION MANUAL

EXTRA 330LX

MANUFACTURER

EXTRA Flugzeugproduktions- und Vertriebs- GmbH
Flugplatz Dinslaken
46569 Hünxe, Federal Republic of Germany

WARNING

This is an Information Manual and may be used for general purposes only.

This Information Manual is not kept current.

It must not be used as a substitute for the official FAA/EASA Approved Pilot's Operating Handbook required for operation of the airplane.

Left blank intentionally

LOG OF REVISIONS

Dates of issue for original and revised pages:	Date and sign of approval:
Original 4. February 2011	EASA MAJOR CHANGE APPROVAL 10034512 Date of Approval 8. April 2011
Revision No. 1 31. May 2012	Approved under the authority of DOA N° EASA.21J.073 (ANAC Validation Process; EASA Project N° 0010017605) Date of Approval 8. October 2012
Revision No. 2 6. November 2012	EASA MAJOR CHANGE APPROVAL 10045828 Date of Approval 22. July 2013
Revision No. 3 5. September 2013	EASA MAJOR CHANGE APPROVAL 10046661 Date of Approval 09. October 2013
Revision No. 4 12. March 2014	Approved under the authority of DOA N° EASA.21J.073 (ref. ÄM-300-14-03, -04 & -05) 12. March 2014
Revision No. 5 29. September 2014	Approved under the authority of DOA N° EASA.21J.073 (ref. ÄM-300-14-09, -10, -12 & -14) 29. September 2014

LOG OF EFFECTIVE PAGES

Page	Date	Page	Date
Title	4. February 2011	920-6	4. February 2011
i thru ii	29. September 2014	920-7	5. September 2013
iii thru vi	4. February 2011	920-8	4. February 2011
1-1 thru 1-4	4. February 2011	921-1	12. March 2014
1-5	29. September 2014	921-2	31. May 2012
1-6 thru 1-8	4. February 2011	921-3 thru 921-5	12. March 2014
2-1	6. November 2012	921-6	31. May 2012
2-2 thru 2-4	4. February 2011	922-1 thru 922-16	6. November 2012
2-5	5. September 2013	923-1 thru 923-10	12. March 2014
2-6	29. September 2014	924-1 thru 924-8	29. September 2014
2-7	4. February 2011		
2-8	29. September 2014		
2-7 thru 2-14	4. February 2011		
2-15 thru 2-16	6. November 2012		
3-1 thru 3-8	4. February 2011		
4-1	6. November 2012		
4-2 thru 4-6	4. February 2011		
4-7	29. September 2014		
4-8 thru 4-11	4. February 2011		
4-12 thru 4-13	5. September 2013		
4-14	6. November 2012		
5-1 thru 5-12	4. February 2011		
5-13	5. September 2013		
5-14 thru 6-9	4. February 2011		
6-10 thru 6-11	12. March 2014		
6-12 thru 6-13	5. September 2013		
6-14 thru 6-18	29. September 2014		
6-15	5. September 2013		
6-16	12. March 2014		
7-1 thru 7-9	4. February 2011		
7-10	29. September 2014		
7-11 thru 8-4	4. February 2011		
9-1 thru 9-2	29. September 2014		
9-3 thru 9-4	4. February 2011		
901-1 thru 905-4	4. February 2011		
906-1	6. November 2012		
906-2	4. February 2011		
906-3 thru 906-6	6. November 2012		
907-1 thru 907-2	4. February 2011		
907-3	5. September 2013		
907-4 thru 916-8	4. February 2011		
917-1	6. November 2012		
917-2 thru 917-3	4. February 2011		
917-4	6. November 2012		
917-5	4. February 2011		
917-6 thru 917-12	6. November 2012		
918-1 thru 918-8	29. September 2014		
919-1 thru 920-2	4. February 2011		
920-3	5. September 2013		
920-4	4. February 2011		
920-5	5. September 2013		

Left blank intentionally

INTRODUCTION

This handbook contains 9 sections, and includes the material required to be furnished to the pilot by FAR Part 23. It also contains supplementary data supplied by EXTRA Flugzeugproduktions- und Vertriebs- GmbH.

THIS MANUAL IS FURNISHED TO THE CIVIL AVIATION AUTHORITIES AS A PART OF THE CERTIFICATION MATERIAL FOR THIS MODEL.

NOTES

This Flight Manual applies only to the aircraft whose nationality and registration marks are noted on the title page.

This Flight Manual is only valid in connection with the latest approved revision. Refer to the EXTRA Homepage (direct link: <http://www.extraaircraft.com/techserv.asp>), where the POH Revision Index always shows the current revision status.

It is the responsibility of the pilot to be familiar with the contents of this Flight Manual including revisions and any relevant supplements.

Pages of this Airplane Flight Manual must not be exchanged and no alterations of or additions to the approved contents may be made without the EXTRA Flugzeugproduktions- und Vertriebs- GmbH/EASA approval. The editor has the copyright of this Flight Manual and is responsible for edition of revisions/ amendments and supplements.

Amendments, which affect the airworthiness of the aircraft will be announced in the mandatory Service Bulletins issued by the manufacturer EXTRA Flugzeugproduktions- und Vertriebs- GmbH coming along with the "Airworthiness Directive" (AD) publication issued by the EASA. The owner is responsible for incorporating prescribed amendments and should make notes about these on the records of amendments.

Should this Flight Manual get lost, inform EXTRA Flugzeugproduktions- und Vertriebs- GmbH, Flugplatz Dinslaken 46569 Hünxe, Federal Republic of Germany.

Should this Flight Manual be found, kindly forward it to the civil board of aviation in the country the aircraft is registered.

WARNINGS, CAUTIONS AND NOTES

The following definitions apply to Warnings, Cautions, and Notes:



=> Operating procedures, techniques, etc., which could result in personal injury or loss of life if not carefully followed.



=> Operating procedures, techniques, etc., which could result in damage to equipment if not carefully followed.

NOTE

=> An operating procedures, technique, etc., which is considered essential to emphasize.

"Shall", "Will", "Should" and "May"

The words "Shall" or "will" is used to express a mandatory requirement. The word "should" is used to express nonmandatory provisions. The word "may" is used to express permissible.

MAINTABLE OF CONTENTS

<i>Section</i>		<i>Page</i>
1	GENERAL	1-1
2	LIMITATIONS	2-1
3	EMERGENCY PROCEDURES	3-1
4	NORMAL PROCEDURES	4-1
5	PERFORMANCE	5-1
6	WEIGHT & BALANCE/EQUIPMENT LIST	6-1
7	AIRPLANE & SYSTEMS DESCRIPTIONS	7-1
8	AIRPLANE HANDLING, SERVICE & MAINTENANCE	8-1
9	SUPPLEMENTS	9-1

**SECTION 1
GENERAL**

Table of Contents

<i>Paragraph</i>		<i>Page</i>
1.0	DESCRIPTION	1-3
1.1	SPECIFICATION OF CLASS	1-3
1.2	MANUFACTURER	1-3
1.3	TECHNICAL DATA	1-3
1.3.1	3-View Drawing	1-3
1.3.2	Main Data	1-4
1.3.3	Wing	1-4
1.3.4	Horizontal Tail	1-4
1.3.5	Elevator	1-4
1.3.6	Vertical Tail	1-4
1.3.7	Rudder	1-4
1.4	ENGINE	1-5
1.5	PROPELLER	1-5
1.5.1	Exhaust System	1-5
1.6	FUEL	1-5
1.7	OIL	1-5
1.8	LOADING	1-6
1.9	TERMINOLOGY	1-6
1.10	SECONDARY TERMINOLOGY	1-7
1.11	CONVERSION TABLE	1-7

Left blank intentionally

1.0 DESCRIPTION

The fuselage of the EXTRA 330LX is built of a tig-welded steel-tube construction. Wings, empennage and landing gear are manufactured from composite material.

The aircraft is a two-seater with the rear seat instrumented for pilot in command.

1.1 SPECIFICATION OF CLASS

The aircraft is certified in normal and acrobatic category.

1.2 MANUFACTURER

EXTRA Flugzeugproduktions- und Vertriebs- GmbH,
Flugplatz Dinslaken
46569 Hünxe,
Federal Republic of Germany.

1.3 TECHNICAL DATA

1.3.1 3-VIEW DRAWING

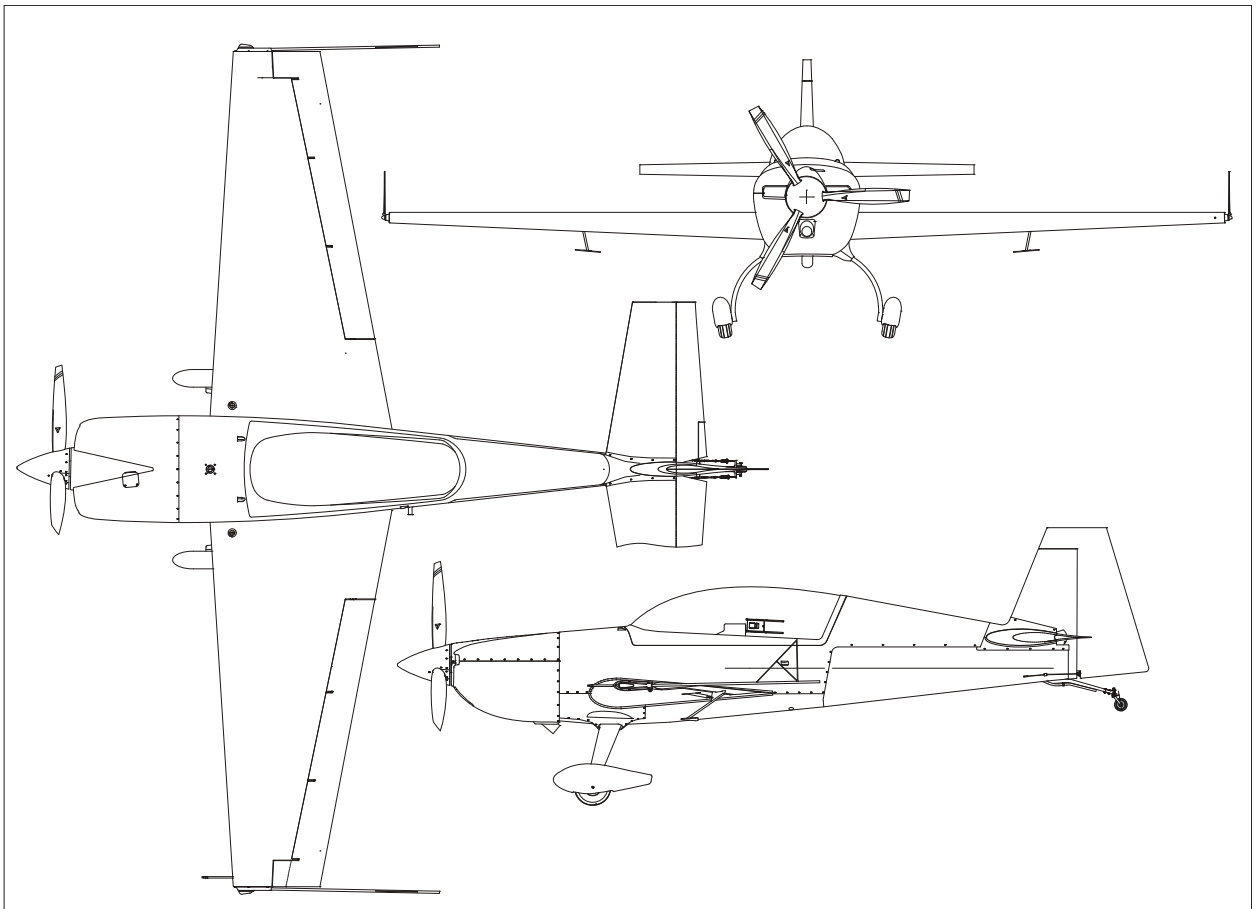

1.3.2 MAINDATA

- Length	7.20 m (23.06 ft)
- Height	2.62 m (8.60 ft)
- Span	8.00 m (26.25 ft)
- Wheel base	5.12 m (16.80 ft)
- Wheel track	1.80 m (5.91 ft)

1.3.3 WING

- Wing span	8.0 m (26.25 ft)
- Wing-area	10.72 m ² (115.39 ft ²)
- Airfoil Root:	MA 15 S
- Airfoil Tip:	MA 12 S
- Chord Root:	1.85 m (6.07 ft)
- Chord Tip:	0.83 m (2.72 ft)
- MAC	1.405 m (4.61 ft)
- Aileron area (without horn balance)	2 x 0.839 m ² (2 x 9.03 ft ²)
- Aileron area (with horn balance)	2 x 0.876 m ² (2 x 9.43 ft ²)
- Aileron deflection	up/down 30°, tolerance ±2°

1.3.4 HORIZONTAL TAIL

- Span	3.20 m (10.50 ft)
- Area	2.56 m ² (27.56 ft ²)
- Airfoil	Wortmann FX 71-L-150/30

1.3.5 ELEVATOR

- Area	0.768 m ² (8.27 ft ²)
- Elevator-deflection	up 25°, toler. ±2°; down 25°, toler. -2°
- Trim-tab-deflection	up 35°, down 27°, tolerance ±2°

1.3.6 VERTICAL TAIL

- Area	1.55 m ² (16.68 ft ²)
- Airfoil	Wortmann FX 71-L-150/30

1.3.7 RUDDER

- Area (without horn balance)	0.68 m ² (7.32 ft ²)
- Area (with horn balance)	0.75 m ² (8.07 ft ²)
- Rudder deflection	left/right 30°, tolerance ±2°

1.4 ENGINE

Manufacturer: Textron-Lycoming Williamsport Plant PA 17701 USA.
 Type: Lycoming AEIO-580-B1A
 Rated power: 315 HP/235 kW @ 2700 RPM
 303 HP/226 kW @ 2600 RPM
 286 HP/213 kW @ 2400 RPM

1.5 PROPELLER

Manufacturer: MT-Propeller Entwicklung GmbH, Federal Republic of Germany.
 Type: MTV-9-B-C/C 198-25 3-blade constant speed.
 Type: MTV-14-B-C/C 190-130 4-blade constant speed.

1.5.1 EXHAUST SYSTEM

Manufacturer: Gomolzig Flugzeug- und Maschinenbau GmbH, Federal Republic of Germany
 Complete 6 in 1 System with integrated Silencer.

1.6 FUEL

Fuel type AVGAS 100/100 LL (for alternate fuel grades see later issues of Textron Lycoming S.I. No 1070)
 Minimum 100/130 octane. Maximum 115/145 octane.

Total fuel capacity: 189 L (49.9 US.gal)
 - Wingtanks (2 x 60 L): 120 L (31.7 US.gal)
 - Center tank: 60 L (15.9 US.gal)
 - Acro tank: 9 L (2.3 US.gal)

Usable fuel capacity in the system: 187 L (49.4 US.gal)
 Usable fuel capacity for acrobatic: 67 L (17.7 US.gal)

1.7 OIL

Maximum sump capacity: 15.13 L (16 US.qt)
 Minimum sump capacity: 8.51 L (9 US.qt)

Average ambient air temperature	Mil-L6082 grades	Mil-22851 ashless dispersant grades
All temperatures	----	SAE 15W50 or 20W50
> 27°C (80°F)	SAE 60	SAE 60
> 16°C (60°F)	SAE 50	SAE 40 or 60
- 1°C til 32°C (30°F - 90°F)	SAE 40	SAE 40

1.7 OIL (Cont.)

Average ambient air temperature	Mil-L6082 grades	Mil-22851 ashless dispersant grades
- 18°C til 21°C (0°F - 70°F)	SAE 30	SAE 30,40 or 20W40
- 18°C til 32°C (0°F - 90°F)	SAE 20W50	SAE 20W50 or 15W50
< -12°C (10°F)	SAE 20	SAE 30 or 20W30

(single or multi - viscosity aviation grade oils see latest issue of Textron Lyc. S.I. No. 1014)

1.8 LOADING

Wing loading @ MTOW	Normal/Acrobatc III	88.62 kg/m ²	(18.15 lbs/ft ²)
	Acrobatc II	81.16 kg/m ²	(16.63 lbs/ft ²)
	Acrobatc I	76.49 kg/m ²	(15.67 lbs/ft ²)
Power loading @ MTOW	Normal/Acrobatc III	4.04 kg/kW	(6.65 lbs/hp)
	Acrobatc II	3.70 kg/kW	(6.09 lbs/hp)
	Acrobatc I	3.49 kg/kW	(5.74 lbs/hp)

1.9 TERMINOLOGY

Air Speeds

CAS	Calibrated Air Speed. CAS is the same as TAS (True Air Speed) in standard atmospheric condition at sea level
KCAS	Calibrated speed in knots
GS	Ground speed
IAS	Indicated air speed
KIAS	Indicated speed in knots
TAS	True air speed. It's the same as CAS compensated for altitude, temperature and density
V _A	Maneuvering speed
V _{NE}	Never exceed speed
V _{NO}	Maximum structural crusing speed
V _S	Stalling speed or minimum steady flight speed
V _X	Best angle-of-climb speed
V _Y	Best rate-of-climb speed

Meteorological terminology

ISA	International standard atmospheric condition
OAT	Outside air temperature

1.10 SECONDARY TERMINOLOGY

fpm	Feet/minute
ft	Feet = 0.3048 m
in	inch = 2.54 cm
m	Meter
L	Litres
US.gal	US (liquid) gallon = 3.79 litres
US.qt	US (liquid) quart = 0.946 litres
hp	Horse power (english)
h	Hour
kts	Knots (nm/h) = 1.852 kilometer per hour
km/h	Kilometer per hour
lbs	English pound = 0.4536 kg
hPa	hekto Pascal
inHg	Inches of mercury
MP	Manifold pressure
PA	Pressure altitude (ft)
nm	Nautical miles = 1.852 km
rpm	Revolutions per minute
CG	Center of gravity
Arm	Arm is the horizontal distance from reference datum
Moment	is the product of weight of an item multiplied by its arm.

1.11 CONVERSIONTABLE

knots <> km/h		km/h <> knots		ft <> m		m <> ft		NM <> km		km <> NM	
60	111	100	54	500	152	250	820	10	19	10	5
65	120	110	59	1000	305	375	1230	20	37	20	11
70	130	120	65	1500	457	500	1640	30	56	30	16
75	139	130	70	2000	610	625	2051	40	74	40	22
80	148	140	76	2500	762	750	2461	50	93	50	27
85	157	150	81	3000	914	875	2871	60	111	60	32
90	167	160	86	3500	1067	1000	3281	70	130	70	38
95	176	170	92	4000	1219	1125	3691	80	148	80	43
100	185	180	97	4500	1372	1250	4101	90	167	90	49
105	194	190	103	5000	1524	1375	4511	100	185	100	54
110	204	200	108	5500	1676	1500	4921	110	204	110	59
115	213	210	113	6000	1829	1625	5331	120	222	120	65
120	222	220	119	6500	1981	1750	5741	130	241	130	70
125	232	230	124	7000	2134	1875	6152	140	259	140	76
130	241	240	130	7500	2286	2000	6562	150	278	150	81
135	250	250	135	8000	2438	2125	6972	160	296	160	86
140	259	260	140	8500	2591	2250	7382	170	315	170	92
145	269	270	146	9000	2743	2375	7792	180	333	180	97
150	278	280	151	9500	2896	2500	8202	190	352	190	103
155	287	290	157	10000	3048	2625	8612	200	370	200	108
160	296	300	162	10500	3200	2750	9022	220	407	250	135
165	306	310	167	11000	3353	2875	9432	240	444	300	162
170	315	320	173	11500	3505	3000	9843	260	482	350	189
175	324	330	178	12000	3658	3125	10253	280	519	400	216
180	333	340	184	12500	3810	3250	10663	300	556	450	243
185	343	350	189	13000	3962	3375	11073	320	593	500	270
190	352	360	194	13500	4115	3500	11483	340	630	550	297
195	361	370	200	14000	4267	3625	11893	360	667	600	324
200	370	380	205	14500	4420	3750	12303	380	704	650	351
205	380	390	211	15000	4572	3875	12713	400	741	700	378
210	389	400	216	15500	4724	4000	13123	420	778	750	405
215	398	410	221	16000	4877	4125	13533	440	815	800	432
220	407	420	227	16500	5029	4250	13944	460	852	850	459
225	417	430	232	17000	5182	4375	14354	480	889	900	486
230	426	440	238	17500	5334	4500	14764	500	926	950	513
235	435	450	243	18000	5486	4625	15174	520	963	1000	540

SECTION 2
LIMITATIONS

Table of Contents

<i>Paragraph</i>		<i>Page</i>
2.1	GENERAL	2-3
2.2	AIR SPEED (IAS)	2-3
2.3	CROSS-WIND COMPONENT	2-3
2.4	ENGINE	2-3
2.4.1	Fuel	2-3
2.4.2	Engine Limitations	2-4
2.5	PROPELLER	2-5
2.6	WEIGHT LIMITS	2-5
2.7	WEIGHT AND C.G. ENVELOPE	2-5
2.7.1	Normal Flight	2-5
2.7.2	Acrobatic Flight	2-5
2.8	ACROBATIC MANEUVERS	2-6
2.8.1	Normal Flight	2-6
2.8.2	Acrobatic Flight	2-6
2.9	LOAD FACTOR	2-7
2.9.1	Normal Flight	2-7
2.9.2	Acrobatic Flight	2-7
2.10	FLIGHT CREW LIMITS	2-8
2.11	KINDS OF OPERATION LIMITS	2-8
2.11.1	Structural Temperature/Colour Limitation	2-8
2.12	MAXIMUM OPERATING ALTITUDE	2-8
2.13	TIRE PRESSURE	2-8
2.14	MARKINGS AND PLACARDS	2-8
2.14.1	Aircraft Identification Plate	2-8
2.14.2	Operating Placards	2-9
2.14.3	Instrument Markings	2-14
2.15	KINDS OF OPERATION EQUIPMENT LIST	2-15

Left blank intentionally

2.1 GENERAL

This section includes operating limitations, instrument markings, and basic placards necessary for the safe operation of the aircraft, its engine, standard systems, and standard equipment. The limitations included in this section have been approved by the EASA. Observance of these operating limitations is required by national aviation regulations.

NOTE

In case of an aircraft equipped with specific options additional information required for safe operation will be contained in Section 9 "Supplements".

Instrument markings and placards are provided for the acrobatic category only; for normal category refer to corresponding limitations. This aircraft is certified under Type Certification Data Sheet (T.C.D.S. EASA.A.362).

Any exceedance of given limitations has to be reported by the pilot so that necessary inspection or maintenance procedures according to the *MAINTENANCE MANUAL EXTRA 330LX* can be performed.

2.2 AIR SPEED (IAS)

Never Exceed Speed	V_{NE}	219 knots	(406 km/h)
Max. Structural Cruising Speed (Normal Cat.)	V_{NO}	138 knots	(256 km/h)
Max. Structural Cruising Speed (Acro Cat. I, II, III)	V_{NO}	154 knots	(285 km/h)
Maneuver Speed (Normal Cat.)	V_A	138 knots	(256 km/h)
Maneuver Speed (Acro Cat. I, II, III)	V_A	154 knots	(285 km/h)
Max. Aileron Control Inputs (Acro Cat. I, II, III)	up to	185 knots	(343 km/h)

2.3 CROSS-WIND COMPONENT

Max. demonstrated cross-wind component for take-off and landing is 15 knots (27 km/h).

2.4 ENGINE

Engine-type: Textron-Lycoming AEIO-580-B1A
Rated maximum power: 235 kW (315 HP) @ 2700 rpm.

2.4.1 FUEL

Minimum grade aviation gasoline: 100/100LL; for alternate fuel grades see latest revision of Lycoming S.I. No. 1070.

Total fuel capacity:	189 L	(49.9 US.gal)
Usable fuel capacity:	187 L	(49.4 US.gal)
Total fuel capacity for acrobatic in acro & center tank:	69 L	(18.2 US.gal)
Usable fuel capacity for acrobatic in acro & center tank:	67 L	(17.7 US.gal)

For acrobatic flight wing tanks must be empty.

2.4.2 ENGINE LIMITATIONS

a) Maximum Rotational Speed

Take-Off and Maximum Continuous: 2700 rpm*

NOTE*

Applicable RPM limitations approved for the MTV-9-B-C/C 198-25 propeller must be observed. Refer to Section 2.5.

b) Oil-temperature

- Maximum 118°C (245°F)

c) Oil capacity

- Maximum sump capacity: 15.13 L (16 US.qt)
- Minimum sump capacity: 8.51 L (9 US.qt)

d) Oil pressure

- Minimum Idling 172 kPa (25 psig)
- Normal 379 - 655 kPa (55 - 95 psig)
- Starting, Warm up, Taxi and Take-Off 793 kPa (115 psig)



It is normal for the oil pressure to "flicker" from 69 to 207 kPa (10 to 30 psig) when going from upright to inverted flight. During knife edge flights and zero-g flights oil pressure may drop and the oil system may not scavenge resulting in engine failure or damage if flight is prolonged. Knife edge and zero-g flight should not exceed 10 seconds.



If oil pressure drops to 0 kPa (psig) the propeller pitch changes automatically to coarse (high) pitch with a corresponding decrease in RPM. Apply positive g to avoid engine stoppage.

e) Fuel pressure

at fuel flow divider:
- Maximum 97 kPa (14 psig)

f) Cylinder head temperature

- Max 241°C (465°F)

2.5 PROPELLER

MT-Propeller Entwicklung GmbH, Federal Republic of Germany

- a) Standard: MTV-9-B-C/C198-25, 3-blade constant speed
- b) Alternative: MTV-14-B-C/C190-130, 4-blade constant speed

Maximum rotational speed

- Take-Off and Maximum Continuous: 2600 rpm*

NOTE*

RPM limitation due to compliance with applicable noise protection requirements (ICAO Annex 16 and FAR 36). However for non-US registered airplanes an enhanced rotational speed limitation of 2700 RPM may be permissible when registered in the Acrobatic Category only as ICAO Annex 16 grants an exception for airplanes specially designed for acrobatic purposes.

2.6 WEIGHT LIMITS

Max allowed empty weight:

- Normal category 738 kg (1627 lbs)
- Acrobatic category III 742 kg (1636 lbs)
- Acrobatic category II 662 kg (1460 lbs)
- Acrobatic category I 686 kg (1513 lbs)

Max allowed T/O weight:

- Normal category & Acrobatic category III 950 kg (2095 lbs)
- Acrobatic category II 870 kg (1918 lbs)
- Acrobatic category I 820 kg (1808 lbs)

Max allowed landing weight: 950 kg (2095 lbs)

2.7 WEIGHT AND C.G. ENVELOPE

Vertical reference = fire-wall.

Horizontal reference = upper longerons in cockpit.

2.7.1 NORMAL FLIGHT

Max T/O Weight:	forward C.G.	rear C.G.
950 kg (2095 lbs) (and below)	67.1 cm (26.4")	84.1 cm (33.1")

2.7.2 ACROBATIC FLIGHT

Max T/O Weight:	forward C.G.	rear C.G.
950 kg (2095 lbs) (and below)	67.1 cm (26.4")	84.1 cm (33.1")

2.8 ACROBATIC MANEUVERS

2.8.1 NORMAL FLIGHT

All acrobatic maneuvers are prohibited except stall, chandelle, lazy eight and turns up to 60 degrees bank angle.

2.8.2 ACROBATIC FLIGHT

The plane is designed for unlimited acrobatics (wing tank must be empty). Inverted flight maneuvers are limited to max 4 minutes.

The structure is designed for full aileron control input up to 185 KIAS (343 km/h) in combination with 2/3 of the applicable max. load factor.

Recommended basic maneuver entry speeds are listed in the following list.

NOTE

This airplane is capable up to 10g maneuvers. If acrobatic maneuvers will be performed with a co-pilot or passenger, the pilot should ensure that the co-pilot/passenger has been properly briefed on the physiological effects of high g maneuvers. This briefing should include accepted muscles straining and breathing techniques to counter the physiological effects of high g maneuvers. During the flight, the pilot should ensure the co-pilot/passenger is doing OK.

Check weight and C/G!



Particular caution must be exercised when performing maneuvers at speeds above V_A [154 KIAS (285 km/h)]. Large or abrupt rudder and elevator control inputs above this speed as well as full aileron control inputs above 185 KIAS (343 km/h) may impose unacceptably high loads which exceed the structural capability of the aircraft.

NOTE

For acrobatic maneuvers see Section 4. All maneuvers can be performed in upright and inverted flight attitude.

Maneuvers	Recommended entry speeds IAS		Symbol	Remarks
	min knots (km/h)	max knots (km/h)		
Segment: horizontal Line	V_S	V_{NE}		
45° climbing	80 (148)	V_{NE}		
90° up	V_A	V_{NE}		
45° diving	V_S	V_{NE}		reduce throttle
90° diving	V_S	V_{NE}		reduce throttle
1/4 Loop climb.	100 (185)	190 (352)		
Loop	100 (185)	190 (352)		
Stall turn	100 (185)	190 (352)		
Aileron roll	80 (148)	185 (343)		full deflection
Snap roll	80 (148)	140 (259)		
"tail slide"	100 (185)	190 (352)		
Spin	V_S			
Inverted spin	V_S			
Knife edge	>150 (278)			< 10 s
Inverted Flight	> V_S	190 (352)		< 4 min

2.9 LOADFACTOR

2.9.1 NORMAL FLIGHT

MTOW 950 kg (2095 lbs)

+ 6 g / - 3 g

2.9.2 ACROBATIC FLIGHT

Category I MTOW 820 kg (1808 lbs)

+ 10 g / - 10 g for 1 seat occupied

Category II MTOW 870 kg (1918 lbs)

+ 8 g / - 8 g for 2 seat occupied

Category III MTOW 950 kg (2095 lbs)

+ 6 g / - 6 g for 2 seat occupied

2.10 FLIGHT CREW LIMITS

Minimum crew is one pilot in the rear seat. Solo flying from rear seat only. Maximum 2 persons are allowed. For hearing protection noise suppression (passive or active) communication headsets are required. The rear cockpit is equipped with a complete set of airplane controls and instruments.

2.11 KINDS OF OPERATION LIMITS

Only VFR flights at day are allowed. The A/C may be operated at OAT from -20°C (-4°F) to +44°C (+111°F). Below temperatures of -10°C (+14°F) the oil vent line must be modified by the low temperature kit (breather line). Flight in known icing-conditions is prohibited. Smoking is prohibited.

2.11.1 STRUCTURAL TEMPERATURE/COLOUR LIMITATION

Structure is qualified up to 72°C (161.6°F). Structure temperatures (composite) above 72°C (161.6°F) are not permitted. Not to exceed this temperature limit, color specification for composite structure (manufacturer document EA-03205.19) has to be complied with. To check the temperature inside the cockpit (potential "green house" effect) a reversible temperature indicator (*STRUCTURAL OVERHEAT INDICATOR*) is applied on the upper side of the wing main spar in the carry-through section. After reaching the temperature limit of 72°C (161,6°F) the word "RISK" appears and flying is prohibited.



2.12 MAXIMUM OPERATING ALTITUDE

Max. certified operating altitude is 10,000 ft (3048 m) MSL

2.13 TIRE PRESSURE

The tire pressure is 3.4 bar (49 psi).

2.14 MARKINGS AND PLACARDS

2.14.1 AIRCRAFT IDENTIFICATION PLATE

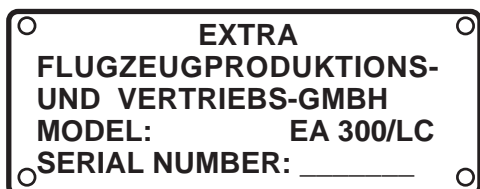

*)The latest national aviation regulations must be observed in determining whether the placard is required.

2.14.2 OPERATING PLACARDS

V_A = 154 KTS (ACRO)
V_A = 138 KTS (NORMAL) or **V_A = 285 km/h (ACRO)**
V_A = 256 km/h (NORMAL)

(near the airspeed indicator)

The markings and placards installed in this airplane contain operating limitations which must be complied with when operating this airplane in the acrobatic category. Other limitations that must be complied with when operating this airplane in this category or in the normal category are contained in the airplane flight manual. Applicable RPM limitations must be observed.

(in the rear cockpit)

This airplane is certified for VFR day operation. Operation under known icing conditions prohibited.

(on the rear instrument panel)

F U E L
AVGAS 100/100LL

(near each filler cap)

OIL

(on the separate hatch of the upper cowling)

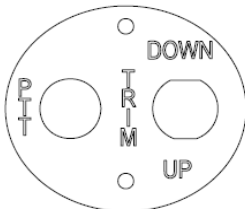

(On the rear control stick)

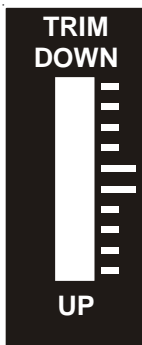

(On the rear instrument panel on the trim LED indicator)

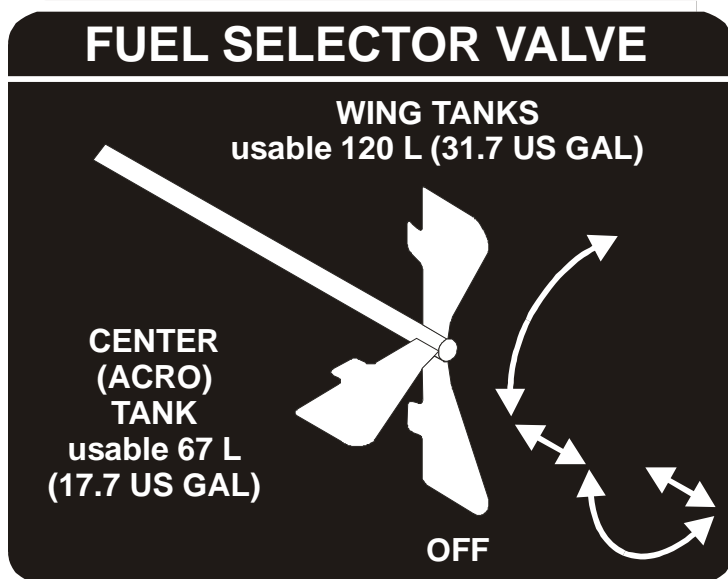

(in both cockpits next to the fuel selector)

**WING TANK
MUST BE EMPTY FOR ACROBATICS.
USABLE FUEL 120L (31.7 US GAL).**

(On the rear instrument panel beneath wing tank fuel capacity indicator)

**CENTER TANK INDICATION
SHOWS "ZERO" IN LEVEL FLIGHT
BELOW 9 L (2.4 US GAL).
UNUSABLE FUEL 2 L (0.5 US GAL)**

(On the rear instrument panel beneath center tank fuel capacity indicator)

**THE REMAINING FUEL IN LEVEL
FLIGHT CANNOT BE USED SAFELY
WHEN INDICATOR READS "ZERO"!**

(On the rear instrument panel beneath the acro & center tanks fuel capacity indicators)

**ACROBATIC:
±10 G, 1 Pilot, MTOW: 820 kg (1808 lbs)
± 8 G, 2 Persons on board, MTOW: 870 kg (1918 lbs)
± 6 G, 2 Persons on board, MTOW: 950 kg (2095 lbs)**

(In both cockpits)

**NORMAL: +6G / -3G MTOW 950 KG (2095 LBS)
ACROBATICS INCL. SPIN NOT APPROVED!**

(In both cockpits)

NO SMOKING

(In both cockpits)

**USE OF HEADSET IS REQUIRED
USE OF PARACHUTE IS RECOMMENDED**

(On the right side of both instrument panels)

LOW RPM ← PROP → HIGH RPM

(On RPM control in the rear cockpit)

LEAN ← MIXTURE → RICH

(On mixture control in the rear cockpit)

CLOSE ← THROTTLE → OPEN

(Near throttle control in both cockpits)

CANOPY LOCK
LOCK ← ● → UNLOCK ●

(near canopy locking handles of each cockpit)

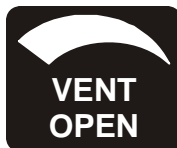
**VENT
OPEN**

(Near the eyeball-type adjustable vents)

CAUTION

Particular caution must be exercised when performing maneuvers at speeds above V_A [154 KIAS (285 km/h)]. Large or abrupt rudder and elevator control inputs above this speed as well as full aileron control inputs above 185 KIAS (343 km/h) may impose unacceptably high loads which exceed the structural capability of the aircraft.

(In both cockpits)

**WARNING:
SOLO FLYING FROM
REAR SEAT ONLY!**

(In front instrumental panel)

CALLSIGN

(In both cockpits)

For	N	030	060	E	120	150
Steer						
For	S	210	240	W	300	330
Steer						

(Near Mag. Dir. Indicator)

WING TANK DRAIN

(Near the LH drain valve in the bottom fuselage cover)

CENTER TANK DRAIN

(Near the RH drain valve in the bottom fuselage cover)

GASCOLATOR DRAIN

(Near the drain valve on the RH lower side of the firewall)

**USE STRAIGHT MINERAL OIL
FOR A MINIMUM OF 50 HOURS**

(On the inside of the separate hatch / upper cowling)

**3.4 BAR
49 PSI**

(On the outside of the wheel fairings)

**TORQUE TUBE
LUBRICATION**

(On the centreline of bottom fuselage cover)

////////// NO STEP! \\\生////

(In rear cockpit, on the aileron control rods)

NO HANDHOLD

(In rear cockpit, on the LH side of the panel cover)

NO BAGGAGE

(On the FOD protection cover behind the pilot seat)



(In both cockpits, on the RH side)

Approved acrobatic maneuvers and recommended entry airspeeds					
Maneuvers	Airspeeds		Maneuvers	Airspeeds	
	min KIAS	max KIAS		min KIAS	max KIAS
Segment:					
Horizontal Line	V_S	V_{NE}	Aileron roll	80	185
45° climbing	80	V_{NE}	Snap roll	80	138
90° up	V_A	V_{NE}	"Tail-slide"	100	190
45° diving	V_S	V_{NE}	Spin	V_S	----
90° diving	V_S	V_{NE}	Inverted spin	V_S	----
1/4 Loop climb.	100	190	Inverted flight (Less than 4 min)	$>V_S$	190
Loop	100	190	Knife edge (Less than 10 s)	>150	----
Stall turn	100	190			

or

Approved acrobatic maneuvers and recommended entry airspeeds					
Maneuvers	Airspeeds		Maneuvers	Airspeeds	
	min km/h	max km/h		min km/h	max km/h
Segment:					
Horizontal Line	V_S	V_{NE}	Aileron roll	148	343
45° climbing	148	V_{NE}	Snap roll	148	256
90° up	V_A	V_{NE}	"Tail-slide"	185	352
45° diving	V_S	V_{NE}	Spin	V_S	----
90° diving	V_S	V_{NE}	Inverted spin	V_S	----
1/4 Loop climb.	185	352	Inverted flight (Less than 4 min)	$> V_S$	352
Loop	185	352	Knife edge (Less than 10 s)	>278	----
Stall turn	185	352			

(in both cockpits)

**) call sign placard

2.14.3 INSTRUMENT MARKINGS

AIR SPEED INDICATOR

green arc	64 KIAS (119 km/h) - 154 KIAS (285 km/h)
yellow arc	154 KIAS (285 km/h) - 219 KIAS (406 km/h)
red line	219 KIAS (406 km/h)

OIL PRESSURE INDICATOR

red line	25 psig
yellow arc	25 psig - 55 psig
green arc	55 psig - 95 psig
yellow arc	95 psig - 115 psig
red line	115 psig

OIL TEMPERATURE INDICATOR

yellow arc	< 140 °F
green arc	140°F - 210°F
yellow arc	210°F - 245°F
red line	245°F

CYLINDER HEAD TEMPERATURE INDICATOR

yellow arc	< 150°F
green arc	150°F - 435°F
yellow arc	435°F - 465°F
red line	465°F

RPM INDICATOR

green arc	700 rpm - 2600/2700* rpm
red line	2600/2700* rpm

*) Refer to Section 2.4.2 and 2.5.

G - METER

green arc	- 5 g - + 8 g
yellow arc	+ 8 g - + 10 g
red line	+ 10 g

FUEL FLOW INDICATOR

green arc	0 gal/h - 35 gal/h
red radial	35 gal/h

	NORMAL	ACROBATIC	
		1 seat	2 seats
ENGINE INDICATION			
1. RPM indicator	1	1	1
4. Manifold pressure indicator	1	1	1
2. Exhaust gas temperature indicator	0	0	0
3. Cylinder head temperature indicator	1	1	1
OIL			
1. Oil temperature indicator	1	1	1
2. Oil pressure indicator	1	1	1
FLIGHT CREW EQUIPMENT			
1. Parachute rear	0	*	*
2. Parachute front	0	0	*
3. Seat belt rear	1	1	1
4. Seat belt front	1	0	1
5. Headset rear	1	1	1
6. Headset front	1	0	1

NOTE

The zeros (0) used in the above list mean that either the equipment or system, or both were not required for type certification for that kind of operation.

Either equipment or systems in addition to those listed above may be required by the national operating regulations.

The asterisks (*) used in the above list mean that latest national aviation regulations must be observed in determining whether the equipment and/or system are required. According FAR Part 91 „General Operating and Flight Rules" each occupant of an US registered airplane must wear an approved parachute when performing acrobatic maneuvers.

Extra Flugzeugproduktions- und Vertriebs- GmbH considers acrobatics without wearing an approved parachute to be unsafe.

SECTION 3
EMERGENCY PROCEDURE

Table of Contents

<i>Paragraph</i>		<i>Page</i>
3.0	INTRODUCTION	3-3
3.0.1	General	3-3
3.0.2	General Behaviour in Emergency Situations	3-3
3.1	AIRSPEEDS FOR EMERGENCY OPERATION	3-4
3.2	OPERATIONAL CHECKLIST	3-4
3.2.1	Engine Failure during Take-off Roll	3-4
3.2.2	Engine Failure immediately after Take-off	3-4
3.2.3	Engine Failure during Flight (Restart Process)	3-4
3.2.4	Loss of Oil Pressure	3-5
3.2.5	High Oil Temperature	3-5
3.2.6	Alternator Failure	3-5
3.3	FORCED LANDINGS	3-6
3.3.1	Emergency Landing without Engine Power	3-6
3.3.2	Precautionary Landing with Engine Power	3-6
3.4	FIRES	3-6
3.4.1	During Start on Ground	3-6
3.4.2	If Engine Fails to Start	3-7
3.4.3	Engine Fire in Flight	3-7
3.5	ICING	3-7
3.5.1	Inadvertent Icing Encounter	3-7
3.6	UNINTENTIONAL SPIN	3-7
3.7	MANUAL BAIL-OUT	3-7
3.8	EMERGENCY EXIT AFTER TURN OVER	3-8
3.9	ELEVATOR CONTROL FAILURE	3-8

Left blank intentionally

3.0 INTRODUCTION

3.0.1 GENERAL

This section contains the checklist and procedures coping with emergencies that may occur. This checklist must be followed in various emergencies to ensure maximum safety for the crew and/or aircraft.

Thorough knowledge of these procedures will enable the aircrew to better cope with an emergency. The steps should be performed in the listed sequence. However the procedures do not restrict the aircrew from taking any additional action necessary to deal with the emergency.

3.0.2 GENERAL BEHAVIOUR IN EMERGENCY SITUATIONS

As soon as one of the crew member becomes aware that an emergency situation exists, he must immediately alert the other crew member of the situation. In any emergency situation, contact should be established with a ground station as soon as possible after completing the initial corrective action. Include **position, altitude, heading, speed, nature of the emergency and pilot's intentions** in the first transmission. There after the ground station should be kept informed of the progress of the flight and of any changes or developments in the emergency. Three basic rules apply to most emergencies and should be observed by each aircrew member:

1. Maintain aircraft control
2. Analyze the situation and take proper action
3. Land as soon as possible/as soon as practical

The meaning of "*as soon as possible*" and "*as soon as practical*" as used in this section is as follows:

Land AS SOON AS POSSIBLE (ASAP) = Emergency conditions are urgent and require an immediate landing at the nearest suitable airfield, considering also other factors, such as weather conditions and aircraft mass.

Land AS SOON AS PRACTICAL= Emergency conditions are less urgent and in the aircrews judgement the flight may be safely continued to an airfield where more adequate facilities are available.



Make only one attempt to restore an automatically disconnected power source or reset or replace an automatically disconnected CPD (circuit protection device) that affects flight operations or safety. Each successive attempt to restore an automatically disconnected power source, or the resetting of an automatically disconnected CPD can result in progressively worse effects.

3.1 AIRSPEEDS FOR EMERGENCY OPERATION

Stall speed	64 KIAS (119 km/h)
Engine failure after take-off	90 KIAS (167 km/h)
Best recommended gliding speed (glide angle 1 : 6,2)	
-Normal & Acro III Category 950 kg (2095 lbs)	90 KIAS (167 km/h)
-Acro II 870 kg (1918 lbs)	87 KIAS (161 km/h)
-Acro I 820 kg (1808 lbs)	85 KIAS (157 km/h)
Precautionary landing with engine power	90 KIAS (167 km/h)
Landing without engine power	90 KIAS (167 km/h)
Maximum demonstrated cross wind component	15 Knots (27 km/h)

3.2 OPERATIONAL CHECKLIST

3.2.1 ENGINE FAILURE DURING TAKE-OFF ROLL

1. Throttle	IDLE
2. Brakes	APPLY
3. Mixture	IDLE CUT OFF
4. Ignition switch	OFF
5. Battery switch	OFF
6. Alternator switch	OFF

3.2.2 ENGINE FAILURE IMMEDIATELY AFTER TAKE-OFF

Stall speed 64 KIAS (119 km/h)

1. Airspeed	90 KIAS (167 km/h)
2. Mixture	IDLE CUT OFF
3. Fuel shutoff valve	OFF (Pull & Turn)
4. Ignition switch	OFF
5. Battery switch	OFF
6. Alternator switch	OFF
7. Forced landing	PERFORM as practical

3.2.3 ENGINE FAILURE DURING FLIGHT (RESTART PROCESS)

1. Airspeed	90 KIAS (167 km/h)
2. Fuel shutoff valve	CENTER & ACRO
3. Mixture	RICH
4. Boost pump	ON
5. Ignition switch	BOTH (or START if propeller has stopped)

3.2.4 LOSS OF OIL PRESSURE

- | | |
|---------------------------------------|---------------------------|
| 1. Positive "g" | Apply |
| If oil pressure is not regained then: | |
| 2. Airspeed | 90 KIAS (167 km/h) |
| 3. Throttle | REDUCE AS REQUIRED |
| 4. Engine oil temperature | OBSERVE INDICATION |
| 5. Land | ASAP |
| | BE PREPARED FOR POWER OFF |
| | LANDING |



If oil pressure drops to 0 psi (kPa) the propeller pitch changes automatically to coarse (high) pitch with a corresponding decrease in RPM.

3.2.5 HIGH OIL TEMPERATURE

- | | |
|-------------|---------------------------|
| 1. Throttle | REDUCE |
| 2. Mixture | ENRICH; if practical |
| 3. Airspeed | INCREASE, if practical |
| 4. Land | ASAP |
| | BE PREPARED FOR POWER OFF |
| | LANDING |

3.2.6 ALTERNATOR FAILURE

An alternator failure is indicated by the red light of the low voltage monitor.

If red light illuminates:

- | | |
|-------------------------------|------------|
| 1. Digital voltage indication | CROSSCHECK |
|-------------------------------|------------|

If indication is above 13 V, alternator is in function:

- | | |
|-----------|----------|
| 2. Flight | CONTINUE |
|-----------|----------|

if it is not:

- | | |
|-------------------------------|---------------------|
| 3. rpm | CHECK min. 2500 rpm |
| 4. Alternator switch | OFF AND ON |
| 5. ALTERNATOR circuit breaker | PULL AND RESET |
| 6. Low voltage monitor | CHECK INDICATION |

If red light is off:

- | | |
|-----------|----------|
| 7. Flight | CONTINUE |
|-----------|----------|

If red light illuminates again:

- | | |
|---------|----------------------|
| 8. Land | AS SOON AS PRACTICAL |
|---------|----------------------|

3.3 FORCED LANDINGS

3.3.1 EMERGENCY LANDING WITHOUT ENGINE POWER

- | | |
|-----------------------------------|--------------------|
| 1. Seat belts, shoulder harnesses | SECURE |
| 2. Airspeed | 90 KIAS (167 km/h) |
| 3. Mixture | IDLE CUT OFF |
| 4. Fuel shutoff valve | OFF (Pull & Turn) |
| 5. Ignition switch | OFF |
| 6. Battery switch | OFF |
| 7. Alternator switch | OFF |
| 8. Touchdown | SLIGHTLY TAILLOW |
| 9. Brakes | OPTIMUM BRAKING |

3.3.2 PRECAUTIONARY LANDING WITH ENGINE POWER

- | | |
|-----------------------------------|---|
| 1. Seat belts, shoulder harnesses | SECURE |
| 2. Airspeed | 90 KIAS (167 km/h) |
| 3. Selected field | FLY OVER,
noting terrain and obstructions, then
reaching a safe altitude and airspeed |
| 4. Battery switch | OFF |
| 5. Alternator switch | OFF |
| 6. Touchdown | SLIGHTLY TAILLOW |
| 7. Ignition switch | OFF |
| 8. Mixture | IDLE CUT OFF |
| 9. Fuel shutoff valve | OFF (Pull & Turn) |
| 10. Brakes | APPLY HEAVILY |

3.4 FIRES

3.4.1 DURING START ON GROUND

- | | |
|-----------------------|---|
| 1. Cranking | CONTINUE to get a start
which would suck the
flames and accumulated
fuel through the air
inlet and into the engine. |
| 2. Fuel shutoff valve | OFF (Pull & Turn) |
| 3. Power | 1700 RPM for one minute. |
| 4. Engine | SHUT DOWN |
| 5. After engine stop | ABANDON aircraft and
inspect for damage |
| 6. Fire | EXTINGUISH using fire
extinguisher if available |



Do not open engine compartment access doors while engine is on fire.

3.4.2 IF ENGINE FAILS TO START

- | | |
|--------------------------|-------------------|
| 1. Cranking | CONTINUE |
| 2. Throttle | FULL OPEN |
| 3. Mixture | IDLE CUT OFF |
| 4. Fuel shutoff valve | OFF (Pull & Turn) |
| If fire is extinguished: | |
| 5. Battery switch | OFF |
| 6. Alternator switch | OFF |
| 7. Ignition switch | OFF |
| 8. Engine compartment | INSPECT |

3.4.3 ENGINE FIRE IN FLIGHT

- | | |
|-----------------------|---|
| 1. Mixture | IDLE CUT OFF |
| 2. Fuel shutoff valve | OFF (Pull & Turn) |
| 3. Battery switch | OFF |
| 4. Alternator switch | OFF |
| 5. Airspeed | 100 KIAS (185 km/h),
find your airspeed/attitude which will keep
the fire away from the cockpit |
| 6. Land | AS SOON AS POSSIBLE |

3.5 ICING

3.5.1 INADVERTENT ICING ENCOUNTER

1. Turn back or change altitude to obtain an outside temperature that is less conducive to icing.
2. Plan a landing at the nearest airfield. With extremely rapid ice build-up select a suitable "off airport" landing field.

3.6 UNINTENTIONAL SPIN

Refer to section 4 (Normal Procedures) acrobatic maneuver, spin recovery.

3.7 MANUAL BAIL-OUT

When in an emergency situation that requires abandoning the aircraft and while wearing a parachute, which is at least strongly recommended for acrobatics:

1. Inform your passenger
2. Reduce speed to 100 KIAS (185 km/h) if possible
3. Pull mixture to lean
4. Open canopy (the low pressure over the canopy in normal flight will flip the canopy full open immediately)
5. Take off headset
6. Open seat belt
7. Leave airplane to the left side
8. Try to avoid wing and tail
9. Open parachute

3.8 EMERGENCY EXIT AFTER TURNOVER

- | | |
|---|-------------------|
| 1. Battery switch | OFF |
| 2. Alternator switch | OFF |
| 3. Fuel shutoff valve | OFF (Pull & Turn) |
| 4. Seat belts | OPEN |
| 5. Parachute harnesses (if wearing a parachute) | OPEN |
| 6. Canopy handle | PULL TO OPEN |

NOTE

If canopy fails to open break the canopy.

- | | |
|-------------|---------------|
| 7. Aircraft | EVACUATE ASAP |
|-------------|---------------|

3.9 ELEVATOR CONTROL FAILURE

In case of elevator control failure the aircraft can be flown with the elevator trim. In this case trim nose up to the desired speed and control horizontal flight or descend with engine power. For landing trim nose up and establish a shallow descend by adjusting throttle. To flare the plane gently increase power to bring the nose up to landing attitude.

SECTION 4
NORMAL PROCEDURES

Table of Contents

<i>Paragraph</i>		<i>Page</i>
4.0	GENERAL	4-3
4.0.1	Airspeeds for Normal Operation	4-3
4.0.2	Checklist and Procedures	4-3
4.1	PREFLIGHT INSPECTION	4-4
4.2	CHECKLIST PROCEDURES	4-4
4.3	STARTING PROCEDURES	4-6
4.3.1	Cold Engines	4-6
4.3.2	Hot Engines	4-6
4.4	TAXIING THE AIRCRAFT	4-6
4.5	TAKE-OFF PROCEDURE	4-7
4.5.1	Before Take-Off	4-7
4.5.2	Take-Off	4-7
4.6	CLIMB	4-8
4.7	CRUISE	4-8
4.8	LANDING PROCEDURES	4-8
4.8.1	Descent	4-8
4.8.2	Approach	4-8
4.8.3	Before Landing	4-8
4.8.4	Normal Landing	4-9
4.9	GO-AROUND	4-9
4.10	SHUTDOWN	4-9
4.11	LEAVING THE AIRCRAFT	4-9
4.12	ACROBATIC MANEUVERS	4-10
4.12.1	General	4-10
4.12.2	Maneuvers	4-10
4.12.3	Spin	4-12
4.13	NOISE CHARACTERISTICS	4-12

Left blank intentionally

4.0 GENERAL

4.0.1 AIRSPEEDS FOR NORMAL OPERATION

CATEGORY	ACRO I	ACRO II	ACRO III	NORMAL
	820 kg (1808 lbs)	870 kg (1918 lbs)	950 kg (2095 lbs)	950 kg (2095 lbs)
	KIAS (km/h)	KIAS (km/h)	KIAS (km/h)	KIAS (km/h)
Start:				
-Rotate Speed	63 (117)	65 (120)	68 (126)	68 (126)
Climb:				
-V _x	91 (169)	92 (170)	96 (178)	96 (178)
-V _y	99 (183)	101 (187)	106 (196)	106 (196)
-Recommended Normal Climb Speed	100 (185)	105 (194)	110 (204)	110 (204)
-Max. Cruise	181 (335)	181 (335)	181 (335)	181 (335)
Landing:				
-Approach	84 (156)	89 (165)	93 (172)	93 (172)
-on Final	76 (141)	78 (144)	82 (152)	82 (152)
-Go-Around Speed	93 (172)	98 (181)	102 (189)	102 (189)
Recommended Airspeed For Flight In Rough Air (max.) (V _A)	154 (285)	154 (285)	154 (285)	138 (256)
Max. Demonstrated Cross Wind Component	15 kts (27)	15 kts (27)	15 kts (27)	15 kts (27)

4.0.2 CHECKLIST AND PROCEDURES

This handbook contains the checklist and procedures to operate the aircraft in normal and acrobatic operation. The pilot should be familiar with all procedures contained in this Pilot's Operating Handbook, which must be carried on board. The pilot has to comply with Checklist for daily check and inspections (see Section 8, Handling, Servicing and Maintenance).

4.1 PREFLIGHT INSPECTION

4.1.1 EXTERIOR INSPECTION ILLUSTRATION

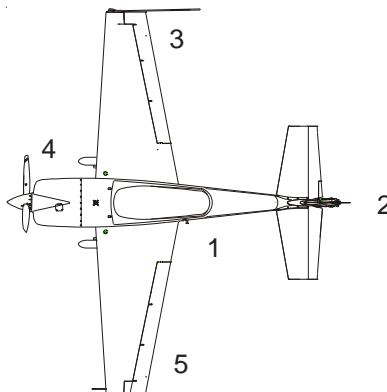

4.1.2 GENERAL

Visually check airplane for general condition during walk around inspection. Perform exterior check as outlined in the picture above in counterclockwise direction.

4.2 CHECKLIST PROCEDURES

1) Cockpit

1. Pilot's Operating Handbook	(AVAILABLE)
2. Airplane weight and balance	CHECKED
3. Ignition switch	OFF
4. Battery switch	ON
5. Fuel quantity indicators	CHECK
6. Battery switch	OFF
7. Fuel selector *	ACRO & CENTER TANK

NOTE*

Although safe operation does not require the use of the tanks in a specific sequence, it is recommended to set fuel selector to "ACRO & CENTER TANK" position!

2) Empennage

1. All round inspection, canopy, surfaces, stabilizer, elevator, trim rudder and tailwheel	CHECK
2. Horizontal stabilizer attachment bolts	CHECK FOR FREEPLAY BY MOVING THE TIP OF THE HORIZ. STABILIZER UP- AND DOWNWARDS

3) Right Wing

1. Aileron, freedom of movement and security	CHECK
2. Trailing edge	CHECK
3. Fuel tank vent opening (right landing gear)	CHECK
4. Fuel quantity	CHECK
5. Fuel tank filler cap	CHECK

-
- | | |
|------------------------------|---|
| 6. Wing fuel tank drain | DRAIN FOR AT LEAST
4 SECONDS TO CLEAR SUMP OF
POSSIBLE WATER;
CHECK CLOSED |
| 7. Right landing gear, wheel | CHECK |

4) Nose

- | | |
|----------------------------------|---|
| 1. Engine oil dipstick | CHECK |
| 2. Propeller and spinner | CHECK |
| 3. Air inlet | CHECK |
| 4. Acro & center fuel tank drain | DRAIN FOR AT LEAST
4 SECONDS TO CLEAR SUMP OF
POSSIBLE WATER;
CHECK CLOSED |
| 5. Fuel filter drain | DRAIN FOR AT LEAST
4 SECONDS TO CLEAR FILTER
OF POSSIBLE WATER;
CHECK CLOSED |
| 6. Exhaust silencer | CHECK FOR DAMAGE AND
SECURE ATTACHMENT |

5) Left wing

- | | |
|--|---|
| 1. Left landing gear, wheel and brakes | CHECK |
| 2. Fuel quantity | CHECK |
| 3. Fuel tank filler cap | CHECK |
| 4. Wing fuel tank drain | DRAIN FOR AT LEAST
4 SECONDS TO CLEAR SUMP OF
POSSIBLE WATER;
CHECK CLOSED |
| 5. Pitot cover | REMOVE |
| 6. Trailing edge | CHECK |
| 7. Aileron, freedom of movement and security | CHECK |

6) Before starting engine

- | | |
|---|-----------------|
| 1. Preflight inspection | COMPLETE |
| 2. Passenger briefing | COMPLETE |
| 3. Parachute handling briefing | COMPLETE |
| 4. Seats, seatbelts, shoulder harnesses | ADJUST AND LOCK |
| 5. Canopy | CLOSE AND LOCK |
| 6. Brake | CHECK |
| 7. Battery switch | ON |
| 8. Avionics power switch | OFF |
| 9. Electrical equipment | OFF |
| 10. Alternator | ON |
| 11. Wingtip position/Strobe lights | ON |

4.3 STARTING PROCEDURES

4.3.1 COLD ENGINES

The following starting procedures are recommended, however, the starting conditions may necessitate some variation from these procedures.

1. Perform pre-flight inspection.
2. Set propeller governor control to "High RPM" position.
3. Open throttle approximately 1/4 travel.
4. Turn boost pump "ON".
5. Move mixture control to "FULL RICH" until a slight but steady fuel flow is noted (approximately 3 to 5 seconds) and return mixture control to "IDLE CUT-OFF". Turn boost pump "OFF".
6. Engage starter.
7. When engine fires release the ignition switch back to "BOTH".
8. Move mixture control slowly and smoothly to "FULL RICH".
9. Check the oil pressure gauge. If minimum oil pressure is not indicated within 30 seconds, shut off the engine and determine cause of trouble.

4.3.2 HOT ENGINES

Because of the fact that the fuel percolates and the system must be cleared of vapor, it is recommended to use the same procedure as outlined for cold engine start.

4.4 TAXIING THE AIRCRAFT

- | | |
|-------------------------|--|
| 1. Canopy | CLOSE AND LOCK |
| 2. Brake | CHECK |
| 3. Altimeter | Set on QFE or QNH
Scale error max. +60 ft |
| 4. Avionic switch | ON |
| 5. Electrical equipment | ON |
| 6. Radio | Set and test |
| 7. Mixture | Leave in "FULL RICH" position |

Operate only with the propeller in minimum blade angle (High RPM).
Warm-up at approximately 1000-1200 RPM. The engine is ready for take-off when the throttle can be opened without the engine faltering.

4.5 TAKE-OFF PROCEDURE

4.5.1 BEFORE TAKE-OFF

Before you line up at the runway for take-off:

Oil pressure and oil temperature	CHECK
Magnetos	CHECK as follows:
Engine RPM:	1800 min ⁻¹

Pay attention to the three small LEDs in the "Status" area on the upper left corner of the P-1000 face:

Ignition switch position:	LEFT
Status area:	Right red LED illuminates
Display:	shows RPM drop
Ignition switch position:	RIGHT
Status area:	Left red LED illuminates
Display:	shows RPM drop
Ignition switch position:	BOTH
Status area:	Right and left red LED remain off The middle LED is not allowed to alert, otherwise the difference is more than permissible.

NOTE

During the short circuit (grounding) of a single magneto, the respective red LED must illuminate. The maximal allowed RPM drop at 1800 min⁻¹ is 175 min⁻¹. The maximum difference between the magnetos shall not to be more than 50 RPM (identify with the illuminated yellow LED).

Alternator output	CHECK
Propeller control	MOVE through its complete range to check operation and return to full HIGH RPM position.
Boost pump	ON (check indicator movement on the fuel flow gauge).
Flight controls	CHECK free and correct
Trim	SET to appropriate takeoff position (half way nose down)

4.5.2 TAKE-OFF

Set throttle smoothly to max and let the airspeed go up to 65-68 KIAS (120-126 km/h). A light pressure on the stick lifts the tail to horizontal position. Rotate the aircraft at 68 KIAS (126 km/h). On reaching climb speed of 110 KIAS (204 km/h) proceed with climb.

4.6 CLIMB

Climbs may be performed up to maximum continuous RPM. RPM above 2400 should, however, be used only when necessary for maximum performance in order to avoid unnecessary noise.

Turn boost pump "OFF".

4.7 CRUISE

- | | |
|-----------------|-------------------------------------|
| 1. Altitude | As selected |
| 2. Throttle/RPM | ADJUST for cruising speed |
| 3. Mixture | ADJUST for minimum fuel consumption |
| 4. Trim | As required |
| 5. Fuel | CHECK periodically |

4.8 LANDING PROCEDURES

4.8.1 DESCENT

- | | |
|-------------------|----------------------|
| 1. Throttle | REDUCE |
| 2. Mixture | "FULL RICH" |
| 3. RPM Control | SET to 2400 RPM |
| 4. Trim | ADJUST |
| 5. Fuel selector* | "ACRO & CENTER TANK" |

NOTE*

Although safe operation does not require the use of the tanks in a specific sequence, it is recommended to set fuel selector to "ACRO & CENTER TANK" position!

4.8.2 APPROACH

- | | |
|---------------|-------------------------------|
| 1. Boost pump | ON |
| 2. Mixture | SET to "RICH" |
| 3. Airspeed | REDUCE to approach speed |
| 4. Propeller | SET to low pitch ("HIGH RPM") |

NOTE

It is recommended to set the RPM to 2400 during approach and landing in order to avoid unnecessary noise. In case of "Go Around", RPM control must be set to max. RPM before applying power.

4.8.3 BEFORE LANDING

- | | |
|----------------------|-----------------------------|
| 1. Landing approach | PROCEED |
| 2. Airspeed on final | maintain 82 KIAS (152 km/h) |
| 3. Elevator trim | ADJUST |
-

NOTE

Stall speed will be:

MTOW = 820 kg (1808 lbs):	59 KIAS (109 km/h)
MTOW = 870 kg (1918 lbs):	61 KIAS (113 km/h)
MTOW = 950 kg (2095 lbs):	64 KIAS (119 km/h)

4.8.4 NORMAL LANDING

- | | |
|------------------|--|
| 1. Landing | PERFORM as practicable with respect to surface and weather condition |
| 2. Landing light | As desired |

NOTE

The rudder is effective down to 30 KIAS (56 km/h)

- | | |
|--------------|------------------|
| 3. Touchdown | 3 point landing |
| 4. Throttle | CLOSE / IDLE |
| 5. Braking | Minimum required |

4.9 GO-AROUND

Decide early in the approach if it is necessary to go around and then start go-around before too low altitude and airspeed are reached.

Proceed as follows:

- | | |
|----------------|---|
| 1. RPM control | HIGH RPM / Full forward |
| 2. Throttle | OPEN / Take-off power |
| 3. Airspeed | Minimum 102 KIAS (189 km/h)
rotate to go-around altitude |

4.10 SHUTDOWN

- | | |
|--------------------|----------------------------|
| 1. Boost pump | OFF |
| 2. Landing light | OFF |
| 3. Engine | RUN for 1 min. at 1000 RPM |
| 4. Dead cut check | PERFORM |
| 5. Avionic switch | OFF |
| 6. Mixture | IDLE CUT OFF |
| 7. Ignition switch | OFF |
| 8. Battery switch | OFF |

4.11 LEAVING THE AIRCRAFT

- | | |
|----------------|----------------|
| 1. Canopy | CLOSE and LOCK |
| 2. Aircraft | SECURE |
| 3. Pitot cover | ATTACH |
| 4. Log book | COMPLETE |

4.12 ACROBATIC MANEUVERS

4.12.1 GENERAL

NOTE

Prior to executing these maneuvers tighten harnesses and check all loose items are stowed. Start the maneuvers at safe altitude and maximum continuous power setting if not otherwise noted.

For maneuver limits refer to Section 2 LIMITATIONS.

After termination of acrobatic maneuvers the artificial horizon (if installed) must be reset if possible.

At high negative g-loads and zero g-periods it is normal that oil pressure and RPM indication might drop down momentarily returning to normal status at positive g-loads.



The high permissible load factors of the airplane may exceed the individual physiological limits of pilot or passenger. This fact must be considered when pulling or pushing high g's.

4.12.2 MANEUVERS



Particular caution must be exercised when performing maneuvers at speeds above V_A [154 KIAS (285 km/h)]. Large or abrupt rudder and elevator control inputs above this speed as well as full aileron control inputs above 185 KIAS (343 km/h) may impose unacceptably high loads which exceed the structural capability of the aircraft.

Acrobatics is traditionally understood as maneuvers like loop, humpty bump, hammerhead turn, aileron roll etc..

This manual does not undertake to teach acrobatics, however, it is meant to demonstrate the plane's capabilities.

For this reason maneuvers are divided into segments. The segments are described. Limitations are pointed out.

- Segment horizontal line:
A horizontal line may be flown with any speed between V_S and V_{NE}
- Segment line 45° climbing:
The plane will follow the line at max. power. The speed will not decrease below 80 KIAS (148 km/h)

- Segment line 90° up:
Any entry speed may be used. Out of a horizontal pull-up at 200 KIAS (370 km/h) the vertical penetration will be 2.500 ft. The speed will gradually decrease to 0.

NOTE

In extremely long lines a RPM decay may occur. This is related to a loss of oil pressure. Positive g's should be pulled immediately in order to protect the engine. Oil pressure will return immediately.

- Segment line 45° diving:
Throttle must be reduced in order to avoid exceeding V_{NE} .
- Segment line 90° diving:
Throttle must be reduced to idle in order to avoid exceeding V_{NE} .

Above segments may be filled up with aileron rolls or snap rolls. Watch $V_A = 154$ KIAS (285 km/h) for aileron rolls with max. deflection. Snap rolls should not be performed at speeds above 140 KIAS (259 km/h).

- Segment 1/4 loop, climbing:
The minimum recommended speed is 100 KIAS (185 km/h). If the maneuver is to be followed by a vertical line, a higher entry speed is required depending on the expected length of the line. A complete loop can be performed at speeds above 100 KIAS (185 km/h).

NOTE

Since the maximum horizontal speed is 185 KIAS (343 km/h), higher speeds should be avoided in acrobatics since an unnecessary loss of altitude would occur.

- Torque maneuvers:
All maneuvers with high angular velocity associated with high propeller RPM must be considered dangerous for the engine crankshaft.

Although wooden composite propeller blades are used, the gyroscopic forces at the prop flange are extremely high.



CAUTION

If performing a gyroscopic maneuver such as flat spin, power on, or knife edge spin, reduce RPM to 2400 in order to minimize the gyroscopic forces.

4.12.3 SPIN

To enter a spin proceed as follows:

- Reduce speed, power idle
- When the plane stalls:
 - Kick rudder to desired spin direction
 - Hold ailerons neutral
 - Stick back (positive spinning), stick forward (negative spinning)

The plane will immediately enter a stable spin.

- Ailerons against spin direction will make the spin flatter.
- Ailerons into spin direction will lead to a spiral dive.

Above apply for positive and negative spinning.

To stop the spin:

- Apply opposite rudder
- Make sure, power idle
- Hold ailerons neutral
- Stick to neutral position

The plane will recover within 1/2 turn.

Recovery can still be improved by feeding in in-spin ailerons.

NOTE

If ever disorientation should occur during spins (normal or inverted) one method always works to stop the spin:

- **Power idle**
- **Kick rudder to the heavier side
(this will always be against spin direction)**
- **Take hands off the stick**

The spin will end after 1/2 turn. The plane will be in a steep dive in a side-slip. Recovery to normal flight can be performed easily.

NOTE

After six turns of spinning the altitude loss including recovery is 3200 ft.

4.13 NOISE CHARACTERISTICS

The noise level with silencer Gomolzig EA300-606000 (6 in 1) and propeller MTV-9-B-C/C 198-25 at 2600 RPM has been established in accordance with

- ICAO Annex 16, 4th Edition incorporating Amendment 8, Volume 1, Chapter 10 as 77.8 dB(A)

ICAO Annex 16, Appendix C, Amendment 10 as 74.2 dB(A)

The noise level with silencer Gomolzig EA300-606000 (6 in 1) and propeller MTV-14-B-C/C 190-130 at 2600 RPM has been established in accordance with

- ICAO Annex 16, 6th Edition incorporating Amendment 10, Volume 1, Chapter 10 as 74.2 dB(A).

Left blank intentionally

SECTION 5

PERFORMANCE

Table of Contents

<i>Paragraph</i>		<i>Page</i>
5.1	GENERAL	5-3
5.1.1	Performance Charts	5-3
5.1.2	Definitions of Terms	5-3
5.1.3	Sample Problem	5-3
5.2	ISA CONVERSION	5-5
5.3	AIRSPEED CALIBRATION	5-6
5.4	STALL SPEED	5-7
5.5	TAKE-OFF PERFORMANCE	5-8
5.6	RATE OF CLIMB PERFORMANCE	5-9
5.7	TIME TO CLIMB, FUEL TO CLIMB	5-10
5.8	RANGE	5-11
5.9	ENDURANCE	5-12
5.10	CRUISE PERFORMANCE	5-13
5.11	LANDING PERFORMANCE	5-14

Left blank intentionally

SECTION 5

PERFORMANCE

5.1 GENERAL

Performance data charts on the following pages are presented to facilitate the planning of flights in detail and with reasonable accuracy under various conditions. The data in the charts have been computed from actual flight tests with the aircraft and engine in good condition and using average piloting techniques.

It should be noted that the performance information presented in the range and endurance charts allow for 45 minutes reserve fuel at specified speeds. Some indeterminate variables such as engine and propeller, air turbulence and others may account for variations as high as 10% or more in range and endurance. Therefore, it is important to utilize all available information to estimate the fuel required for the particular flight.

5.1.1 Performance Charts

Performance data are presented in tabular or graphical form to illustrate the effect of different variables. Sufficiently detailed information are provided in the tables so that conservative values can be selected and used to determine the particular performance figure with reasonable accuracy.

All speeds in this chapter are Indicated Air Speeds (IAS) except otherwise stated. The performance figures below are given under following conditions.

1. Maximum allowed weight 950 kg (2095 lbs) except otherwise stated
2. Take-off and landing on concrete surface.
3. No wind.
4. Standard atmospheric condition.

5.1.2 Definitions of Terms

For definition of terms, abbreviations and symbols refer to section 1, General.

5.1.3 Sample Problem

TAKE-OFF CONDITIONS

Field Pressure Alt	2000 ft (610 m)
Temperature	15°C (59°F)
Wind Component (Headwind)	8 KT (15 km/h)
Field Length	3000 ft (914 m)

CRUISE CONDITIONS

Total Distance	400 NM (741 km)
Pressure Altitude	8000 ft (2438 m)
Temperature (ISA)	-1°C (30°F)

TAKE-OFF

Take-Off Distance is shown by Fig. 5.5

Example:

- T/O Weight: 870 kg (1918 lbs)
- Ground Roll: 112 m (367 ft)
- Total Distance to clear a 50 ft obstacle: 248 m (813 ft)

These distances are well within the available field length incl. the 8 kts (15 km/h) headwind.

RATE OF CLIMB

Fig. 5.6 shows the Rate Of Climb using Take-off Power

The Rate of Climb at 2000 ft (610 m): 2320 ft/min (11.8 m/s)

The Time to Climb from 2000 ft (610 m) to 8000 ft (2438 m) is acc. to Fig. 5.7:

=> (4,0 - 0,9) min = 3,1 min

The Fuel to Climb from 2000 ft (610 m) to 8000 ft (2438 m) is:

=> (5,8 - 1,4) Liters = 4,4 Liters (1.2 US Gal.)

CRUISE

Cruise Altitude and Power Setting should be determined for most economical fuel consumption and several other considerations. In an altitude of 8000 ft (2438 m) and a Power Setting of 65 % a Fuel Consumption of 52 L/H (13.7 US Gal/H) and 3,25 NM/L (12.3 NM/US Gal) can be obtained by Fig. 5.9.

RANGE AND ENDURANCE

Fig. 5.8 presents Range and Endurance values for a T/O Weight of 950 kg (2095 lbs) including fuel for warm up and Take-Off from SL, max continuous Power climb to cruising altitude, and a reserve of 21 liter (5.5 US Gal.) for 45 minutes with 45% Power. 5,5 liters (1,45 US Gal.) unusable fuel is taken into account.

For the sample problem (appr.)

Total Fuel	171 L	(45.1 US Gal.)
Warm Up & T/O	- 5 L	(1.3 US Gal.)
Reserve	- 21 L	(5.54 US Gal.)
Unusable Fuel-	5.5 L	(1.45 US Gal.)
	=====	=====
Usable Fuel	139.5 L	(36.8 US Gal.)
Range	415 NM	(768 km)
Endurance	2.49 HRS	

5.2 ISA CONVERSION

ISA Conversion of pressure altitude and outside air temperature

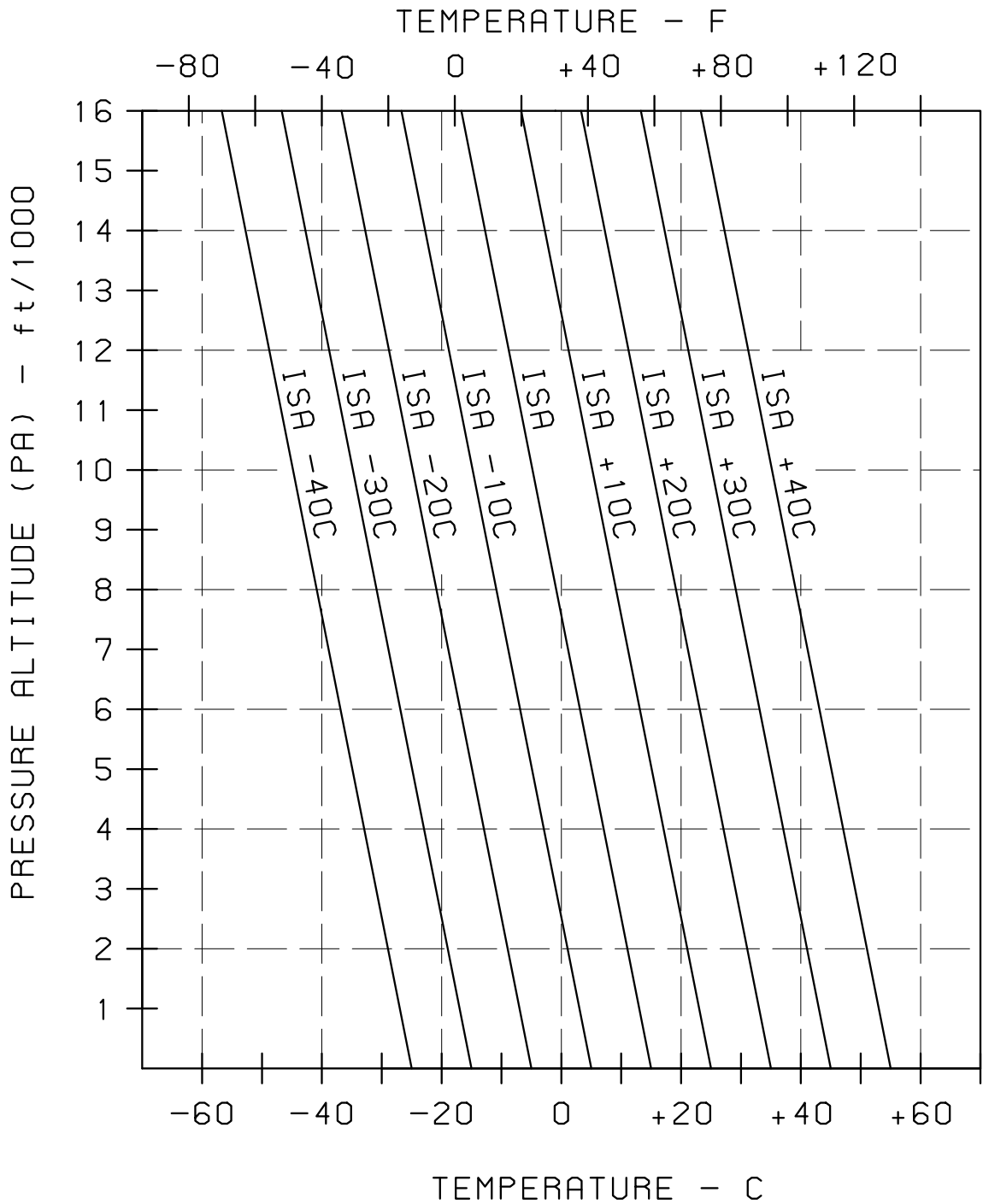

5.3 AIRSPEED CALIBRATION

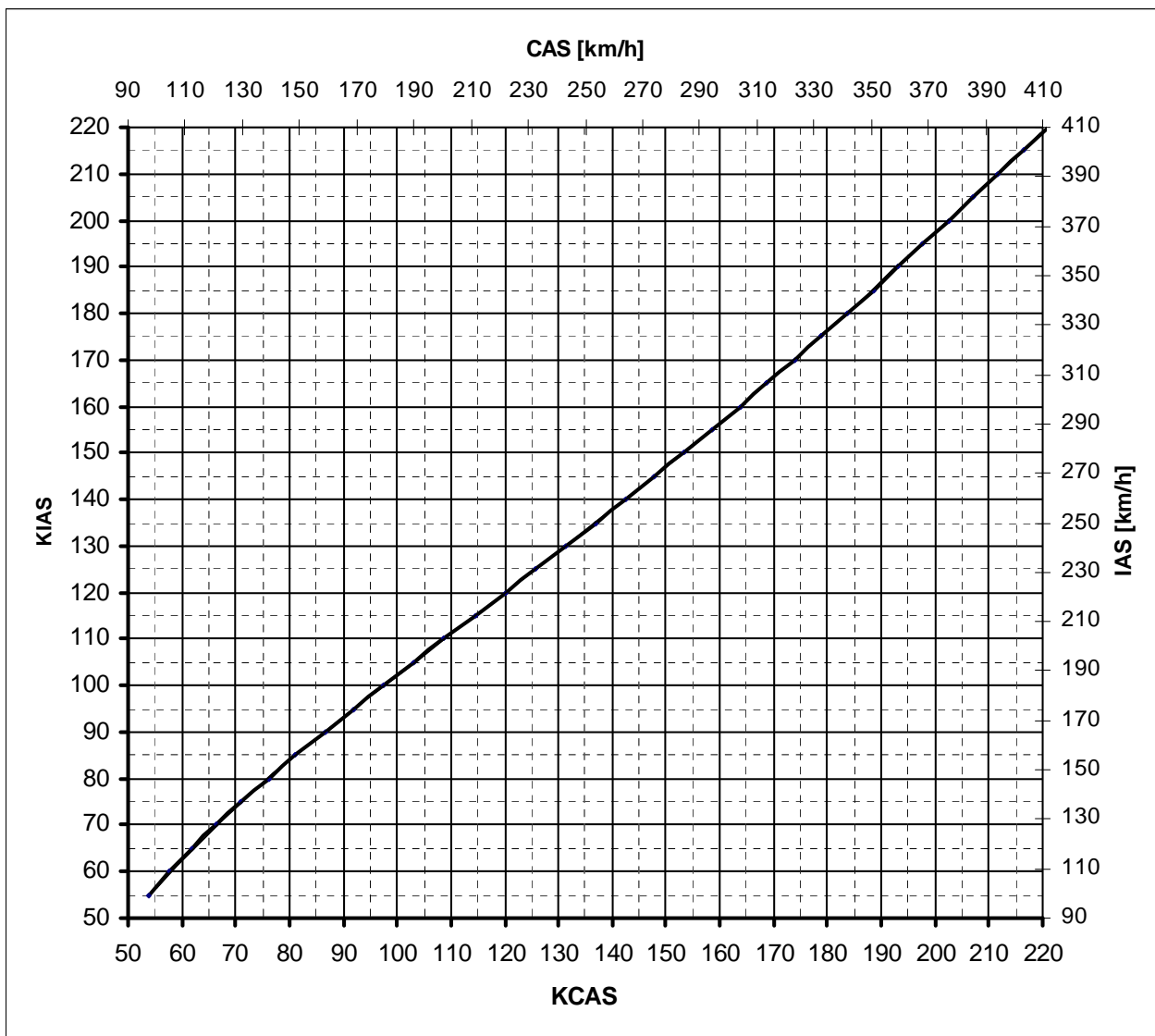

NOTE

Indicated airspeed assumes zero instrument error

5.4 STALL SPEED

CONDITION:

POWER IDLE
FORWARD C/G

STALL SPEEDS

ANGLE OF BANK

WEIGHT kg (lbs)	CATEGORY	0° 1 g	30° 1,15 g	45° 1,41 g	60° 2 g
		KIAS (km/h)	KIAS (km/h)	KIAS (km/h)	KIAS (km/h)
950 (2095)	NORMAL/ACRO III	64 (119)	69 (128)	76 (141)	91 (169)
870 (1918)	ACRO II	61 (113)	66 (122)	73 (135)	87 (161)
820 (1808)	ACRO I	59 (109)	64 (119)	71 (131)	84 (156)

Max altitude loss during stall recovery is approximately 100 ft (30 m)

5.5 TAKE-OFF PERFORMANCE

Power : T/O Power
Runway: Concrete

NOTE

For every 5 kts (9 km/h) headwind, the T/O distance can be decreased by 4%. For every 3 kts (6 km/h) tailwind [up to 10 kts (19 km/h)], the T/O distance is increased by 10%. On a solid, dry and plain grass runway, the T/O is increased by 15%.

OAT			0°C (32°F)		15°C (59°F)		30°C (86°F)	
T/O weight	Rotating Speed	PA	T/O Roll	T/O over 15 m (50 ft)	T/O Roll	T/O over 15 m (50 ft)	T/O Roll	T/O over 15 m (50 ft)
kg (lbs)	KIAS (km/h)	ft (m)	m (ft)	m (ft)	m (ft)	m (ft)	m (ft)	m (ft)
950 (2095)	68 (126)	SL	96 (315)	207 (679)	115 (377)	248 (813)	133 (436)	285 (935)
		2000 (610)	115 (377)	248 (814)	138 (453)	298 (978)	160 (525)	342 (1122)
		4000 (1219)	138 (453)	298 (978)	166 (545)	357 (1171)	192 (630)	410 (1345)
		6000 (1829)	166 (545)	358 (1175)	199 (653)	429 (1407)	230 (755)	492 (1614)
870 (1918)	65 (120)	SL	78 (256)	167 (548)	93 (305)	200 (656)	107 (351)	230 (755)
		2000 (610)	94 (308)	200 (656)	112 (367)	240 (787)	128 (420)	276 (906)
		4000 (1219)	112 (367)	241 (791)	134 (440)	288 (945)	154 (505)	331 (1086)
		6000 (1829)	135 (443)	289 (948)	161 (528)	346 (1135)	185 (607)	397 (1302)
820 (1808)	63 (117)	SL	67 (220)	114 (374)	79 (259)	170 (558)	93 (305)	200 (656)
		2000 (610)	80 (262)	173 (568)	95 (312)	204 (669)	112 (367)	240 (787)
		4000 (1219)	97 (318)	207 (679)	114 (374)	248 (814)	134 (440)	288 (945)
		6000 (1829)	116 (381)	249 (817)	137 (449)	294 (965)	161 (528)	347 (1138)

5.6 RATE OF CLIMB PERFORMANCE

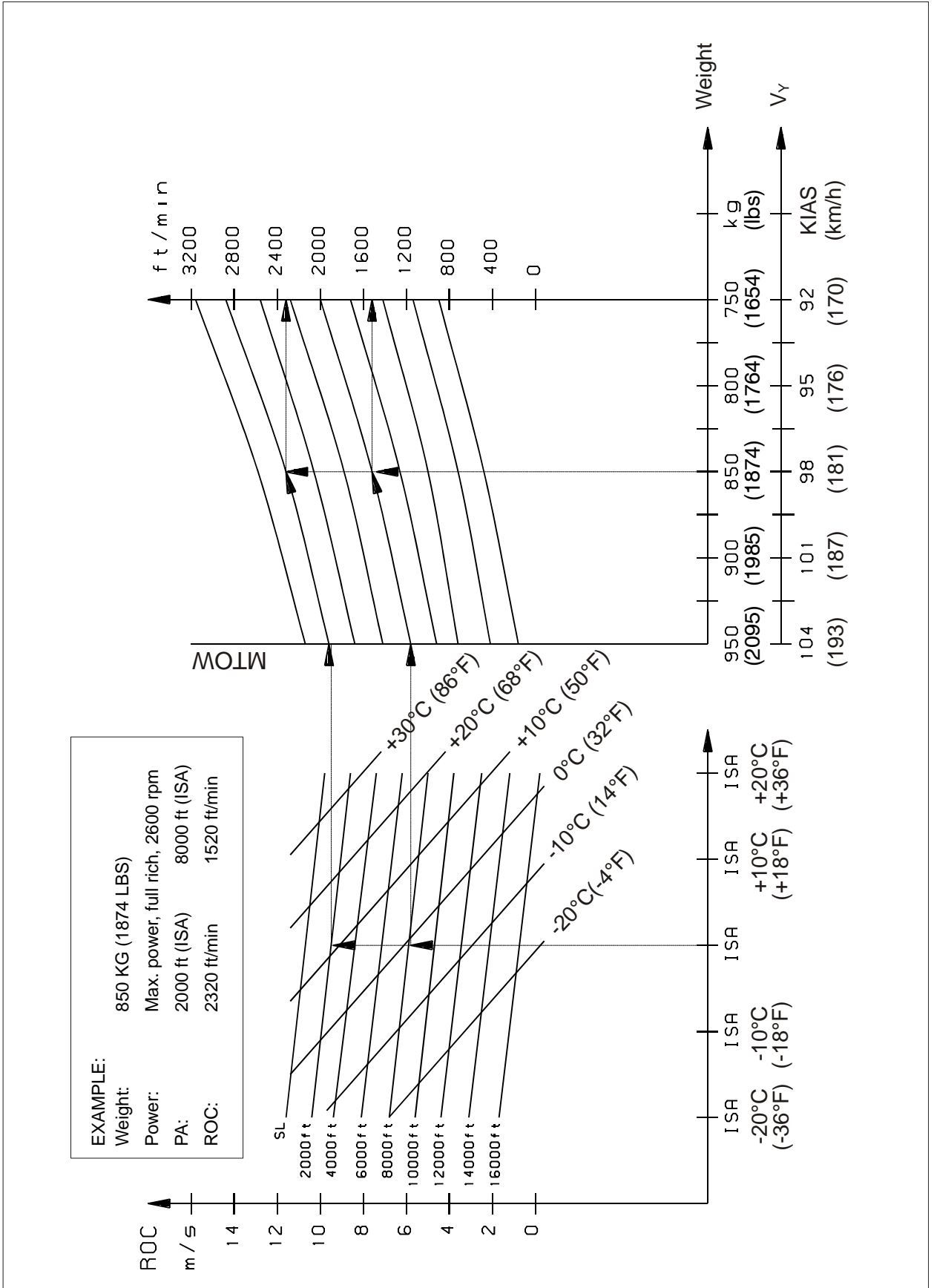

5.7 TIME TO CLIMB, FUEL TO CLIMB

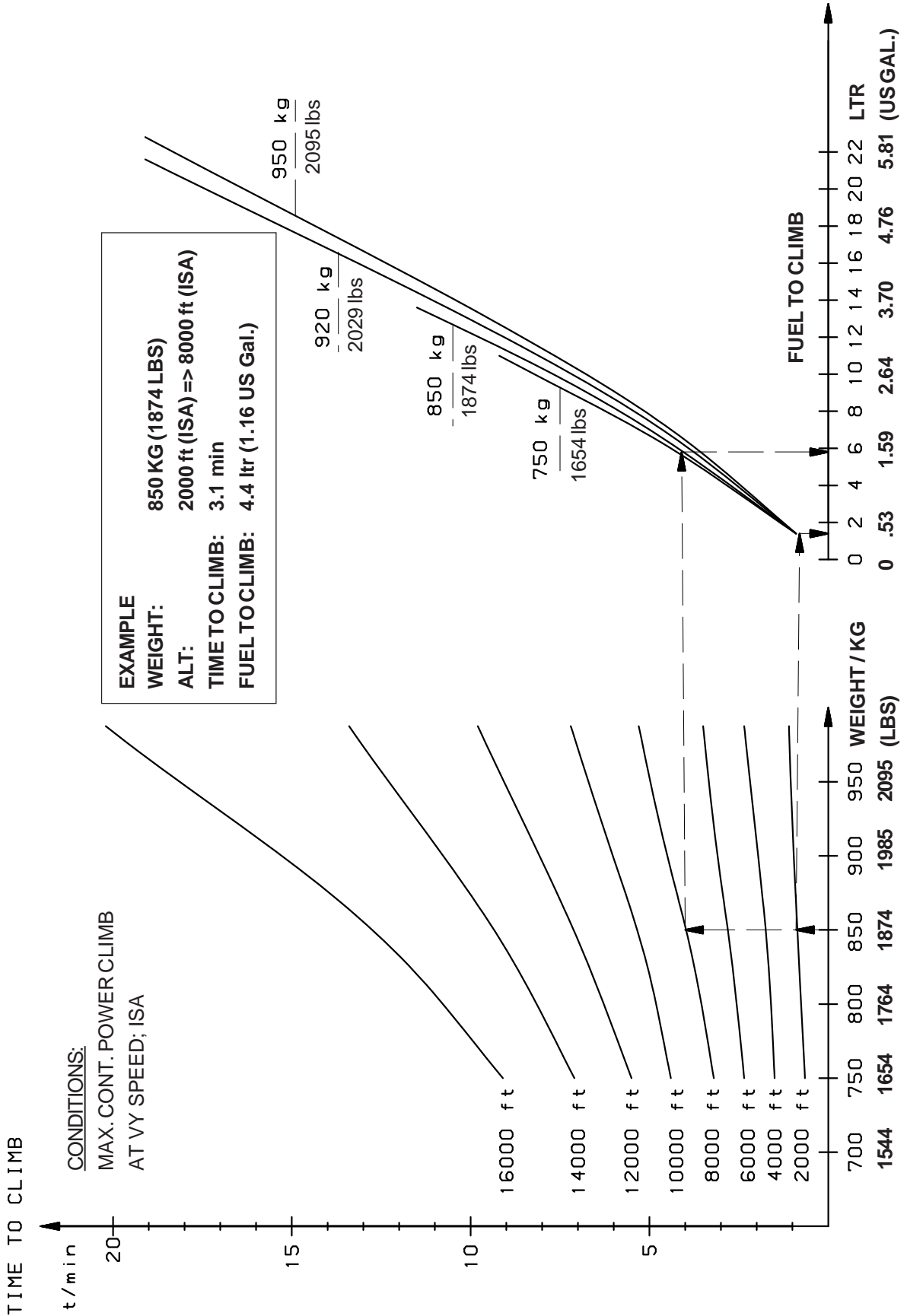

5.8 RANGE

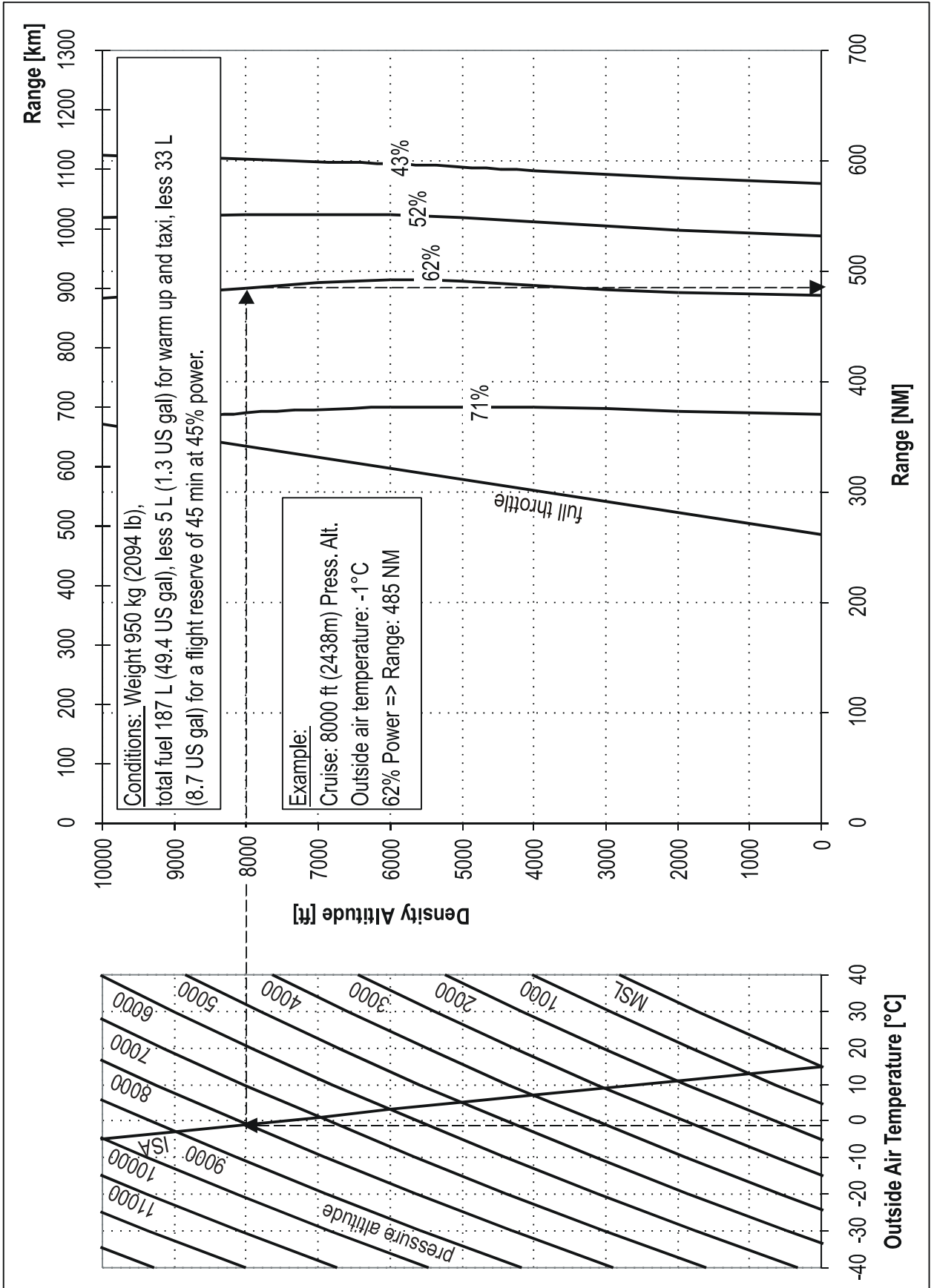

5.9 ENDURANCE

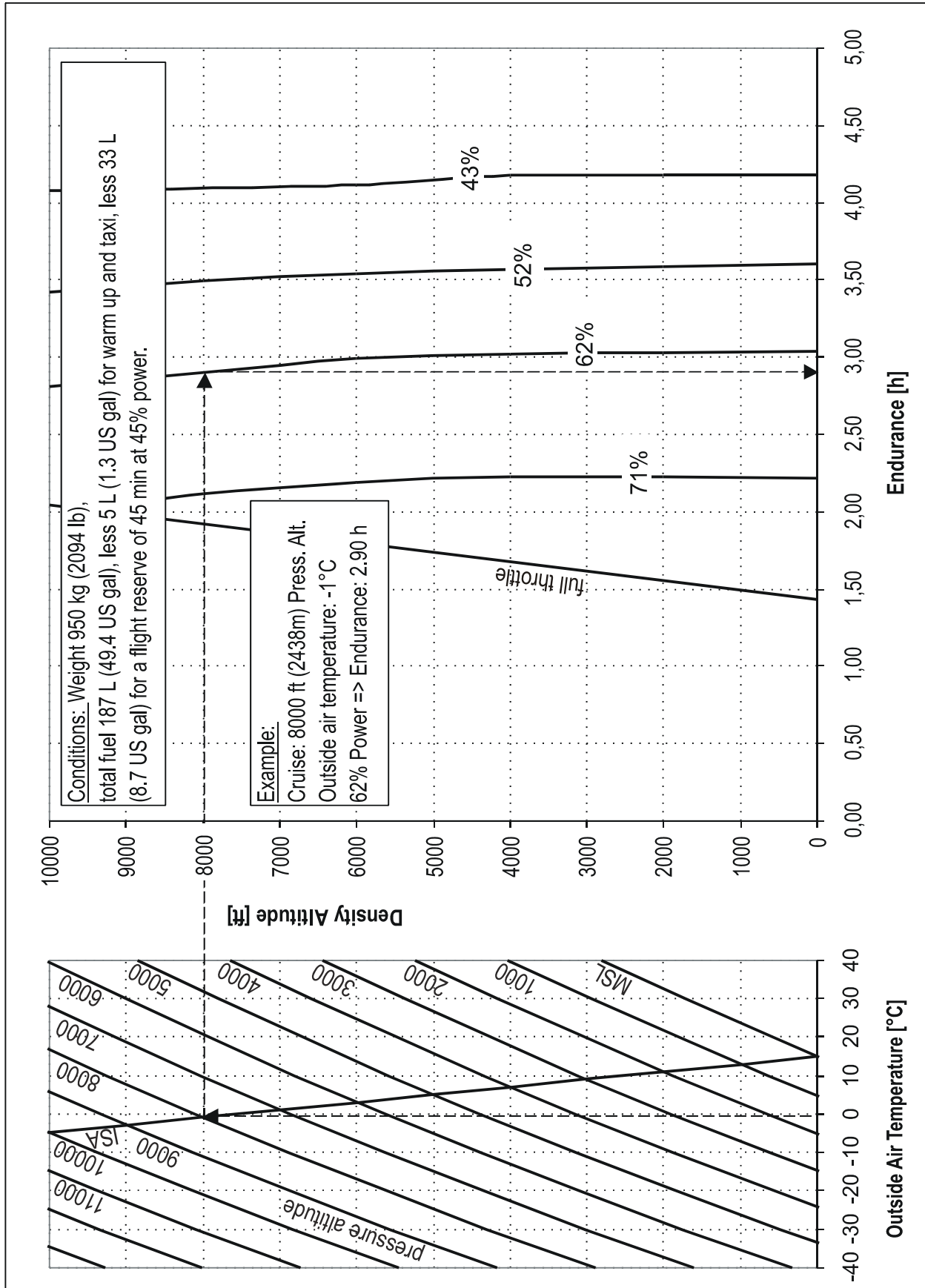

5.10 CRUISE PERFORMANCE

Configuration:

T/O Weight	950 kg (2095 lb)
Acro & Center Tank Fuel Capacity	69 L (18.2 US gal)
Total Fuel Capacity	189 L (49.9 US gal)

Range and Endurance values include fuel for warm-up and Take-Off from SL, max. cont. Power climb to cruising altitude, and a reserve of 21 L (5.55 US gal) for 45 minutes with 45% Power. 2 L (0.53 US gal) unusable fuel is taken into account. (At ISA-Conditions.)

PA [ft] (m)	Eng. [rpm]	Manif. Press. [inHg]	Power Setting		Fuel Consumption		TAS		IAS		Endur. ① [h]	Range ① [nm] (km)		Mixture ② Best ...
			[%]	[hp]	[L/h]	[gal/h]	[kts]	(km/h)	[kts]	(km/h)				
2000 (610)	2700*	26.5	91	286	88.2	(23.3)	182.6	(338)	169	(313)	1.73	317	(587)	Power
	2400	24.0	71	225	68.7	(18.2)	167.6	(310)	156	(289)	2.22	373	(691)	Power
	2200	23.2	62	195	50.5	(13.3)	159.3	(295)	149	(276)	3.03	481	(891)	Economy
	2000	22.5	52	165	42.6	(11.3)	150.2	(278)	141	(261)	3.59	538	(996)	Economy
	2000	19.4	43	135	36.5	(9.6)	139.9	(259)	132	(244)	4.18	584	(1082)	Economy
4000 (1219)	2700*	24.5	85	267	82.7	(21.9)	181.5	(336)	164	(304)	1.85	333	(617)	Power
	2400	23.4	71	225	68.7	(18.2)	170.9	(317)	154	(285)	2.22	378	(700)	Power
	2200	22.7	62	195	50.5	(13.3)	162.4	(301)	147	(272)	3.02	487	(902)	Economy
	2000	21.8	52	165	42.6	(11.3)	153.1	(284)	140	(259)	3.57	544	(1007)	Economy
	2000	19.0	43	135	36.5	(9.6)	142.6	(264)	131	(243)	4.18	591	(1095)	Economy
6000 (1829)	2700*	22.8	79	248	77.6	(20.5)	180.5	(334)	158	(293)	1.97	351	(650)	Power
	2500	22.2	71	225	69.8	(18.4)	174.3	(323)	153	(283)	2.19	377	(698)	Power
	2200	22.2	62	195	50.5	(13.3)	165.6	(307)	146	(270)	3.00	493	(913)	Economy
	2000	21.5	52	165	42.6	(11.3)	156.1	(289)	139	(257)	3.55	551	(1020)	Economy
	2000	18.5	43	135	36.5	(9.6)	145.4	(269)	130	(241)	4.12	598	(1107)	Economy
8000 (2438)	2700*	21.0	73	231	73.4	(19.4)	179.6	(333)	162	(300)	2.08	367	(680)	Power
	2675*	20.7	71	225	71.9	(19.0)	177.8	(329)	153	(283)	2.12	371	(687)	Power
	2350	20.6	62	195	52.0	(13.7)	169.0	(313)	144	(267)	2.90	485	(898)	Economy
	2050	20.6	52	165	43.0	(11.4)	159.3	(295)	137	(254)	3.49	552	(1022)	Economy
10000 (3048)	2700*	19.8	69	215	69.6	(18.4)	178.6	(331)	148	(274)	2.19	382	(707)	Power
	2500	19.2	62	195	53.6	(14.2)	172.4	(319)	143	(265)	2.81	476	(882)	Economy
	2150	19.3	52	165	43.7	(11.5)	162.5	(301)	136	(252)	3.42	549	(1017)	Economy

- ① For temperatures above/below Standard (ISA), increase/decrease Range 1,7% and Endurance 1,1% for each 10°C (18°F) above/below Standard Day Temperature for particular altitude.
- ② Leaning with exhaust gas temperature (EGT) gage. For the adjustment "**Best Power**", first lean the mixture to achieve the top exhaust temperature (peak EGT) and then enrich again until the exhaust temperature is 100°F lower than peak EGT. For the adjustment "**Best Economy**", simply lean the mixture to achieve the top exhaust temperature (peak EGT).



Always return the mixture to full rich before increasing power settings.

*) This RPM setting is not allowed for airplanes registered in the normal category, in which noise protection requirements must be complied with.

5.11 LANDING PERFORMANCE

Power : Idle
Runway: Concrete
Brakes: maximum

NOTE

**For every knot (1.852 km/h) headwind, the landing distance can be decreased by 3%.
On a solid, dry and plain grass runway, the landing is increased by 15%.**

OAT			0°C (32°F)		15°C (59°F)		30°C (86°F)	
Landing weight	Airspeed	PA	Land. Roll	Land. over 15m (50 ft)	Land. Roll	Land. over 15m (50 ft)	Land. Roll	Land. over 15m (50 ft)
kg (lbs)	KIAS (km/h)	ft (m)	m (ft)	m (ft)	m (ft)	m (ft)	m (ft)	m (ft)
950 (2095)	93 (172)	SL	171 (561)	527 (1729)	177 (581)	548 (1798)	185 (607)	586 (1923)
		2000 (610)	181 (594)	558 (1831)	188 (617)	580 (1903)	197 (646)	602 (1975)
		4000 (1219)	192 (630)	592 (1942)	199 (653)	615 (2018)	208 (682)	639 (2096)
		6000 (1829)	203 (666)	627 (2057)	211 (692)	652 (2139)	220 (722)	678 (2224)
870 (1918)	89 (165)	SL	158 (518)	488 (1601)	164 (538)	507 (1663)	171 (561)	527 (1729)
		2000 (610)	165 (541)	518 (1699)	175 (574)	537 (1762)	181 (594)	558 (1831)
		4000 (1219)	177 (581)	548 (1798)	185 (607)	570 (1870)	192 (630)	592 (1942)
		6000 (1829)	188 (617)	582 (1909)	195 (640)	605 (1985)	203 (666)	627 (2057)
820 (1809)	84 (156)	SL	150 (492)	465 (1526)	156 (512)	483 (1585)	163 (535)	502 (1647)
		2000 (610)	159 (522)	492 (1614)	166 (545)	511 (1677)	173 (568)	532 (1745)
		4000 (1219)	168 (551)	522 (1713)	176 (577)	543 (1781)	184 (604)	565 (1854)
		6000 (1829)	179 (587)	553 (1814)	186 (610)	575 (1886)	194 (636)	598 (1962)

SECTION 6

WEIGHT AND BALANCE AND EQUIPMENT LIST

Table of Contents

<i>Paragraph</i>		<i>Page</i>
6.1	GENERAL	6-3
6.2	AIRCRAFT WEIGHING PROCEDURE	6-3
6.2.1	Owners Weight and Balance Record	6-4
6.3	CENTER OF GRAVITY CALCULATION (SAMPLE PROBLEM)	6-5
6.3.1	Sample	6-7
6.3.2	Weight and Balance Record Sheet	6-7
6.4	LOADING WEIGHTS AND MOMENTS	6-8
6.5	WEIGHTS AND MOMENTS LIMITS	6-9
6.6	EQUIPMENT LIST	6-10

Left blank intentionally

6.1 GENERAL

This section describes the procedure for establishing the basic weight and moment of the aircraft. Sample forms are provided for reference. Procedures for calculating the weight and movement for various operations are also provided. A comprehensive list of all equipment available for this aircraft is included. It is the responsibility of the pilot to ensure that the aircraft is loaded properly.

6.2 AIRCRAFT WEIGHING PROCEDURE

The aircraft weight is determined by weighing all three wheel loads simultaneously by three scales with the aircraft levelled.
(Upper fuselage reference line horizontal)

Datum line for weight arms x is the fire wall.

X_1 = distance: fire wall - main wheel

X_2 = distance: fire wall - tail wheel

X_N = distance: fire wall - item N

X_G = distance: fire wall - Center of Gravity

W_1 = Sum of weights indicated by the two scales below the main wheels

W_2 = Weight indicated by the scale below the tail wheel

W = Total weight = $W_1 + W_2$

$XG = \frac{(W_1 \times X_1) + (W_2 \times X_2)}{W}$ = CG position

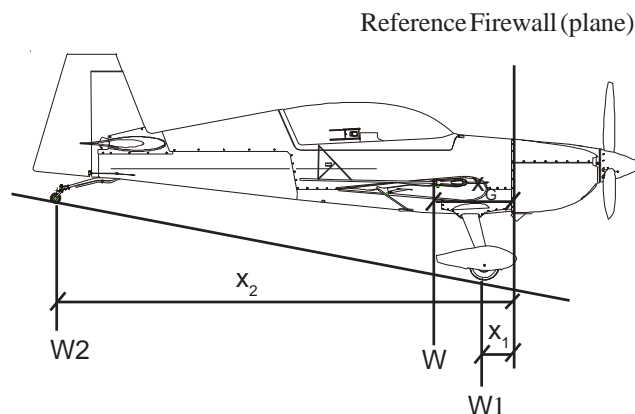

$$W = W_1 + W_2, \quad XG = \frac{(W_1 \times X_1) + (W_2 \times X_2)}{W}$$

If a new weight is added to the known old weight and CG position the resulting new weight and CG can be obtained by a simple calculation:

Situation before adding item:

W_o, X_o = Airplane weight, CG position

W_n, X_n = Weight, distance from fire wall of item to add

New Weight of airplane and new CG:

$$W = W_o + W_n$$

$$XG = \frac{W_o \times X_o + W_n \times X_n}{W} : \text{CG position}$$

6.2.1 Owners Weight and Balance Record

Enter below all weight change data from aircraft log book.

EXTRA 330LX		SERIAL NUM				
Date	Description of modification	Weight change Added (+), Removed (-)			Running empty weight	
		Wt./kg [lbs]	Arm/cm [inch]	Moment/kg*cm [lbs*inch]	Wt./kg [lbs]	Moment/kg*cm [lbs*inch]
	Empty weight as delivered	—	—	—		

6.3 CENTER OF GRAVITY CALCULATION (SAMPLE PROBLEM)

Position	PILOT Rear Seat		ACRO-TANK Fuel 51 LTR (13.4 US GAL)		COPILOT Front Seat		WING-TANK Fuel 120LTR (31,7 US GAL)	
	(kg)	(lbs)	(kg)	(lbs)	(kg)	(lbs)	(kg)	(lbs)
①	90	198.5	-	-	-	-	-	-
②	90	198.5	37	81.5	-	-	-	-
③	90	198.5	37	81.5	-	-	86.4	190.5
④	90	198.5	-	-	60	132.3	-	-
⑤	90	198.5	37	81.5	60	132.3	-	-
⑥	90	198.5	37	81.5	60	132.3	86.4	190.5
⑦	90	198.5	-	-	90	198.5	-	-
⑧	90	198.5	37	81.5	90	198.5	-	-

Position	PILOT Rear Seat		ACRO-TANK Fuel 51 LTR (13.4 US GAL)		COPILOT Front Seat		WING-TANK Fuel 101LTR (26.7 US GAL)	
	(kg)	(lbs)	(kg)	(lbs)	(kg)	(lbs)	(kg)	(lbs)
⑨	90	198.5	37	81.5	90	198.5	73	160.9

6.3 CENTER OF GRAVITY CALCULATION (SAMPLE PROBLEM)

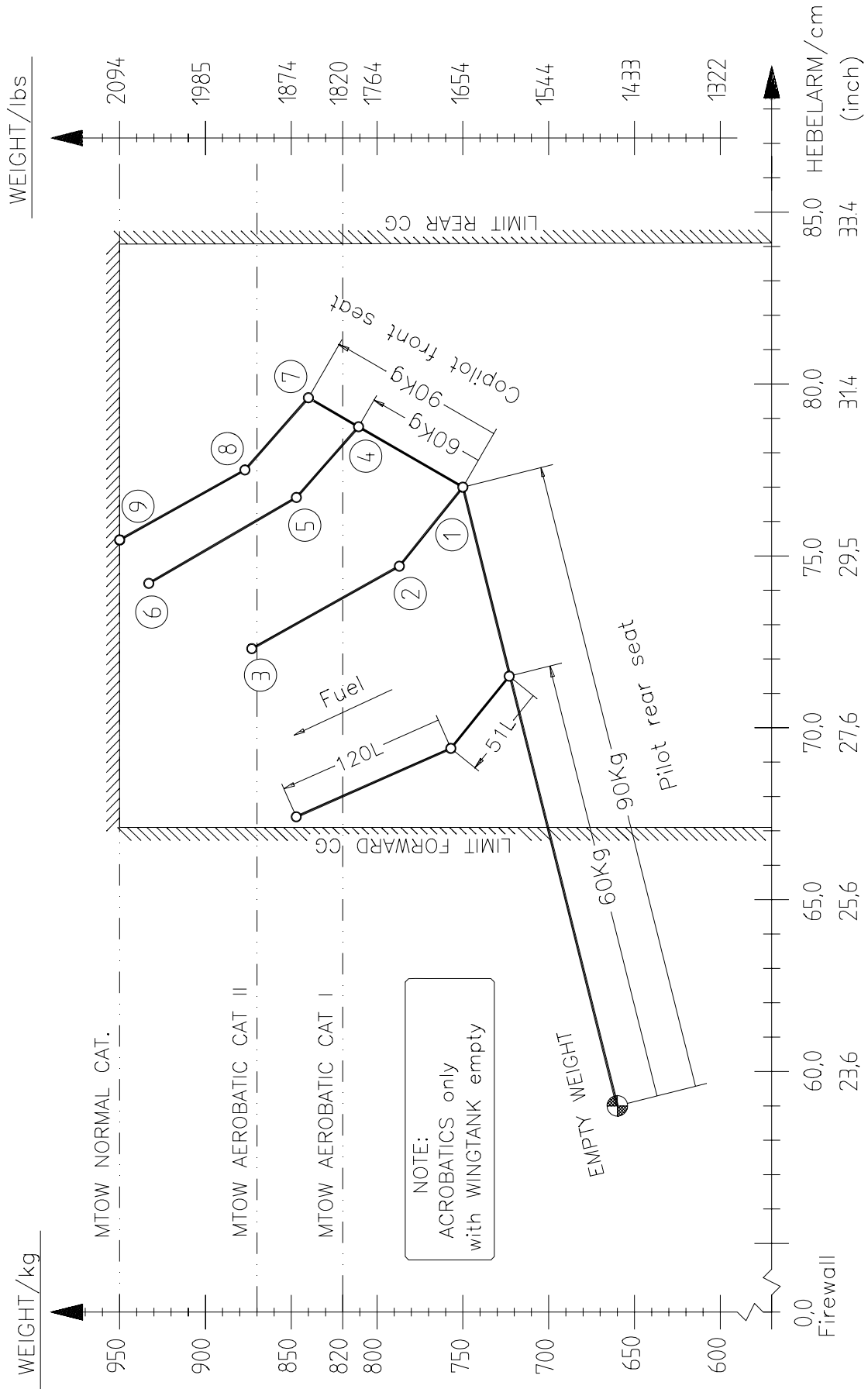

6.3.1 Sample

Take-off Condition:

Pilot On Rear Seat	90.0 kg	(198.5 lbs)
Copilot On Front Seat	90.0 kg	(198.5 lbs)
51 L Fuel in Acro Tanks	37.0 kg	(81.5 lbs)
101 L Fuel In Wing Tanks	73.0 kg	(160.9 lbs)
Aircraft Empty Weight	660.0 kg	(1455 lbs)
	=====	=====
	950.0 kg	(2094.4 lbs)

To find C/G, follow line "Pilot Rear Seat" from Empty Weight to "90 kg" [198.5 lbs] (Point 1). Continue on line "Copilot Front Seat" to 90 kg (Point 7). Now follow line "Fuel" via Point 8 (51 L [13.5 US.gal] Acro Fuel) to Point 9 (101 L [26.6 US.gal] Fuel in Wing Tank).

FIND: Weight ~ 950 kg (2094.4 lbs)
 C/G ~ 75.4 cm (29.6 inch)

6.3.2 Weight and Balance Record Sheet

	WEIGHT	ARM	MOMENT
EMPTYWEIGHT			
PILOT			
COPILOT			
ACROFUEL			
WINGFUEL			

$\Sigma W =$

$\Sigma (W \times X) =$

$$XG = \frac{\Sigma (W \times X)}{\Sigma W} =$$

6.4 LOADING WEIGHTS AND MOMENTS

OCCUPANTS : max. 2

WEIGHT		PILOT		COPILOT	
Pilot + Parachute		<u>REAR SEAT</u> Arm = 207cm (81.5 inch)		<u>FRONT SEAT</u> Arm = 98 cm (38.4 inch)	
KG	LBS	KG x CM	(IN x LBS) MOMENT	KG x CM	(IN x LBS)
60	132	12420	(10758)	5880	(5068)
65	143	13455	(11654)	6370	(5491)
70	154	14490	(12551)	6860	(5913)
75	165	15525	(13447)	7350	(6336)
80	176	16560	(14344)	7840	(6758)
85	187	17595	(15240)	8330	(7180)
90	198	18630	(16137)	8820	(7603)

TOTAL FUEL CAPACITY: 189 L (49.9 US gal)

FUEL					
<u>ACRO & CENTER TANK</u>			<u>WING TANK</u>		
L (USgal)	kg (lb)	kg x cm (lb x in)	L (USgal)	kg (lb)	kg x cm (lb x in)
9 (2.4)	6.5 (14.3)	182 (157)	10 (2.6)	7.2 (15.9)	360 (313)
20 (5.3)	14.4 (31.8)	420 (365)	20 (5.3)	14.4 (31.8)	721 (629)
25 (6.6)	18.0 (39.7)	529 (459)	40 (10.6)	28.8 (63.5)	1442 (1257)
30 (7.9)	21.6 (47.6)	638 (553)	60 (15.9)	43.2 (95.3)	2164 (1886)
35 (9.2)	25.2 (55.6)	746 (648)	80 (21.1)	57.6 (127.0)	2885 (2514)
40 (10.6)	28.8 (63.5)	855 (742)	100 (26.4)	72.0 (158.8)	3607 (3144)
45 (11.9)	32.4 (71.4)	964 (836)	120 (31.7)	86.4 (190.5)	4328 (3771)
50 (13.2)	36.0 (79.3)	1073 (931)			
55 (14.5)	39.6 (87.3)	1182 (1026)			
60 (15.9)	43.2 (95.2)	1290 (1120)			
65 (17.2)	46.8 (103.2)	1399 (1215)			
69 (18.2)	49.7 (109.6)	1487 (1291)			

6.5 WEIGHTS AND MOMENTS LIMITS

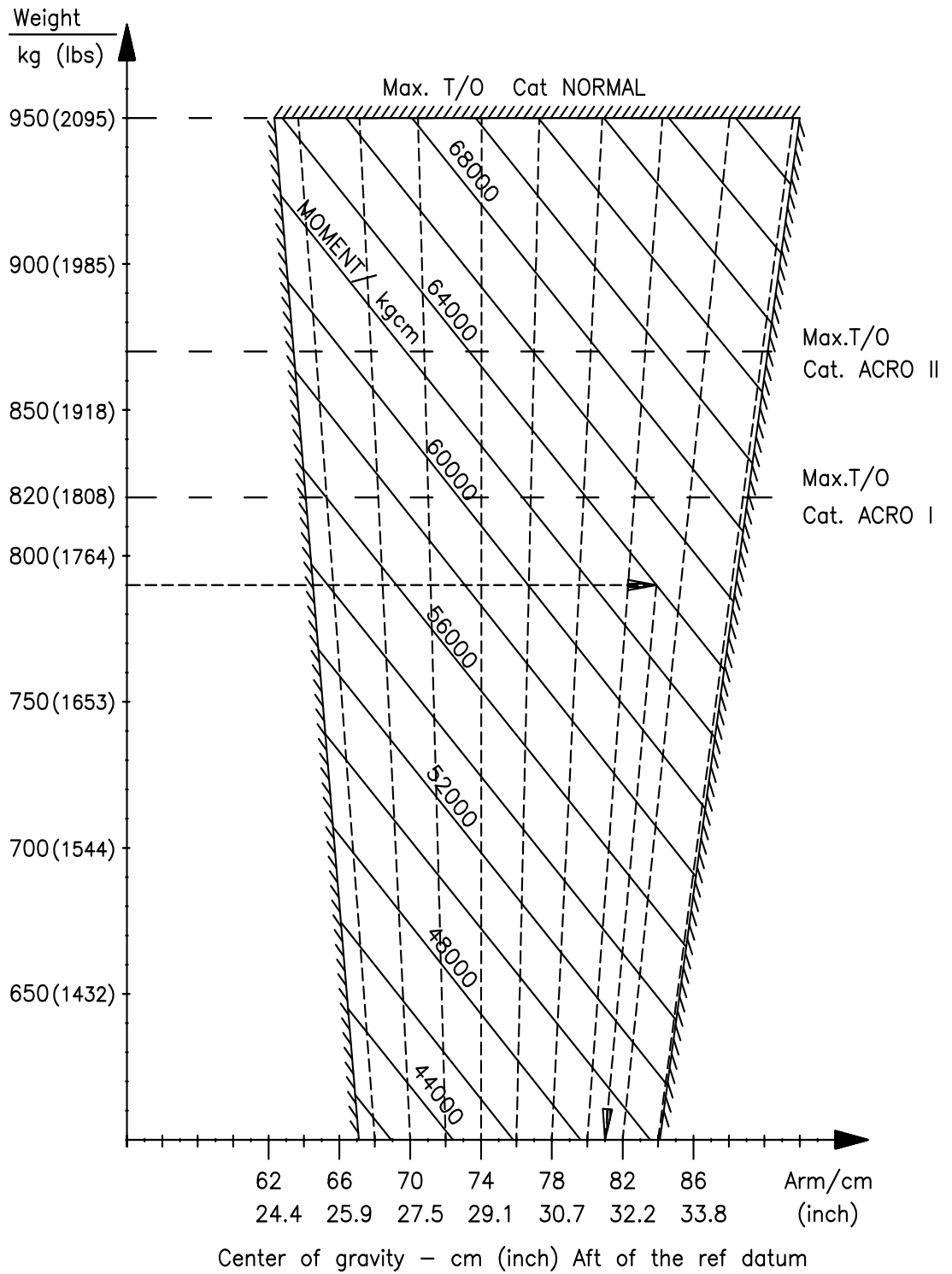

EXAMPLE:
At 790 KG (1741 LBS) and 640000 kgcm the C/G location is 80.0 cm (31.4") aft of ref datum

6.6 EQUIPMENT LIST EXTRA 330LX S/N:

QTY	ITEM	MANUFACT.	MODELNO	PART OR P/N	WEIGHT (kg)	ARM (m)	R* A O	INST
Mooring (10)								
2	Wing Tie Down Rings	Extra		8C801.002	0.05	1.07	O	
1	Canopy Lock	Extra		83401.001-LK	0.25	1.90	O	
Venting and Heating (21)								
1	Heater	Extra	EA-8D606	Option 300/LT KBS01	3.70	0.20	O	
Electrics (24)								
1	Battery	Concorde	RG-25 XC	03617	10.40	0.23	R	
1	Battery Lightweight	Concorde	RG-12LSA	03617	5.90	0.23	A	
1	Alternator 60 Amps	Plane Power	AL12-E160/B	33552	3.00	-0.86	R	
1	Alternator 65 Amps	Prestolite	66021637	33558	4.00	-0.86	A	
1	Alternator 55 Amps	Bosch	0 120 489 917	33508	4.60	-0.86	A	
1	Shunt (100A. 100mV)	Electronics International	S-50	FA3008	0.09	0.25	R	
1	Volt/Ammeter	Electronics International	VA-1A-50	FA3007-PG	0.22	1.62	R	
1	External Power Socket (Piper Type)	Cole Hersee	11041-06	31731	1.46	1.07	O	
1	Batt. Charger Plug 12V	Extra	EA-93102.18	02636	0.02	0.17	O	
1	12VDC Power Outlet Socket	Sutars	1218	31494	0.03	1.62	O	
Cockpit (25)								
1	Safety Belt Assy Rear Seat (seat belts w. ratchet, shoulder harness, crotch strap)	Hooker	(1011230 [3x] & 1113012-1 [1x], 1H5630-3 [2x] 1CS924-D [1x])	FK0002 or FK0019	3.30	2.12	R	
1	Safety Belt Assy Front Seat (seat belts, shoulder harness, crotch strap)	Hooker	1011230 [4x] 1H3030-3 [2x] 1CS924-D [1x]		2.90	1.03	R	
1	Safety Belt Assy Front Seat (seat belts w. ratchet, shoulder harness, crotch strap)	Hooker	(1011230 [3x] & 1113012-1 [1x], 1H3030-3 [2x] 1CS924-D [1x])	FK0004 or FK0020	3.30	1.03	A	
Emergency Equipment								
1	First Aid Pack	Hartmann	7394280	33423	0.39	2.70	R	
Flight Controls (27)								
1	Elevator Trim System Electric	Ray Allen	EA-4D401.0	31668	0.40	4.24	R	
1	Mechanically Adjustable Pedal Sys.	Extra	EA-46304		4.92	1.22	R	
1	Electrically Adjustable Pedals Sys.	Extra	EA-86612		7.28	1.10	A	

*) R = required, A = alternative, O = optional

QTY	ITEM	MANUFACT.	MODELNO	PART OR P/N	WEIGHT (kg)	ARM (m)	R* A O	INST
Fuel System (28)								
1	Elec. Fuel Pump	Weldon Tool	B8120-M		1.10	-0.04	R	
1	Elec. Fuel Pump	Andair	PX580-TC-XT		0.47	-0.04	A	
1	Fuel Selector	Allen	6 S 122	390144	0.19	0.73	R	
+	Fuel Lines in Fuselage	Parker/Statoflex	PTFE Type 124	33315	1.65	0.70	R	
1/2	Fuel Cont. Probe Wing	VDO	226 801 015 001	FM4006	0.12	0.89	R	
1	Fuel Cont. Probe Fuselage Tank	VDO	224 011 020 372	01920	0.20	0.44	R	
Landing gear (32)								
2	Main Wheel Tires 5.00-5 / 6PR	Goodyear	505C61-B	02323	3.90	0.33	R	
2	Tube	Goodyear	302-013-400	FF0016			R	
2	Main Wheel Tires 5.00-5 / 6PR	McCreary	06-08200				A	
2	Tube	McCreary	06-08300				A	
2	Wheel assembly	Cleveland	199-197	02497	6.40	0.33	R	
2	Master Brake Cylinders front	Matco	MC-4E	FB0001	0.55	0.15	R	
2	Master Brake Cylinders rear	Matco	MC-4E	FB0001	0.55	1.11	R	
1	Tail Wheel 6" Assy (Soft)	Special Products Aviation Inc.		32477-VB	1.28	5.23	R	
1	Tail Wheel 5" Steerable	Extra	EA-53201.7	53201.007-VB	0.90	5.23	A	
L/R	Wheel fairing (CRP)	Extra	EA-53102.301		0.33	2.50	R	
1	Brake Fluid Reservoir	ACS	A-315	02889	0.20	0.04	R	
Lights (33)								
1	Strobe / Nav Light (RH)	Whelen	01-0790340-00 (14V green)	32989	0.30	1.35	R	
1	Strobe / Nav Light (LH)	Whelen	01-0790340-02 (14V red)	32990	0.30	1.35	R	
2	Strobe Power Supply	Whelen	A490T	01215	0.54	1.35	R	
1	Strobe/NAV Light (RH)	AVEO	AVE-WPSTG-54G	34334	0.083	1.35	A	
1	Strobe/NAV Light (LH)	AVEO	AVE-WPSTR-54G	34335	0.083	1.35	A	
1	Landing Light LED	Whelen	01-71125-12	33588	0.16	-0.57	O	
Navigation / Flight Instruments / Avionics (34)								
1	Accelerometer 3-1/8"	Kollsman/Pioneer/Bendix/Jaeger/Century	AN 5745	FI3001	0.40	1.60	R	
1	Accelerometer 2-1/4"	Kollsman/Pioneer/Bendix/Jaeger/Century	AN 5745	01206	0.30	1.60	A	
1	Magnetic Compass	SIRS Navigation Ltd	PG2A	33085	0.13	1.62	R	
1	Magnetic Compass	Airpath	C 2300	00189	0.25	1.62	A	
1	Airspeed Indicator front (kts)	United Instr.	UI8030 B.882	32811	0.32	0.65	O	
1	Airspeed Indicator front (kts/km/h)	United Instr.	UI8030 B.896	33630	0.32	0.65	A	

QTY	ITEM	MANUFACT.	MODELNO	PART OR P/N	WEIGHT (kg)	ARM (m)	R* A O	INST
1	Airspeed Ind. front (kts)	Mikrotechna Praha	LUN 1106.K2B4/SC	34155	0.50	0.65	A	
1	Airspeed Ind. front (km/h)	Mikrotechna Praha	LUN 1106.P2B4/SC	34156	0.50	0.65	A	
1	Airspeed Indicator rear (kts)	United Instr.	UI8030 B.882	32811	0.32	1.61	R	
1	Airspeed Indicator rear (kts/km/h)	United Instr.	UI8030 B.896	33630	0.32	1.61	A	
1	Airspeed Ind. rear (kts)	Mikrotechna Praha	LUN 1106.K2B4/SC	34155	0.50	1.61	A	
1	Airspeed Ind. rear (km/h)	Mikrotechna Praha	LUN 1106.P2B4/SC	34156	0.50	1.61	A	
1	Alternate Static Valve	Extra	Assy	300/L Option StatLei	0.15	1.60	O	
1	Altimeter front (ft)	United Instr.	UI5934PD-3 A.134	30416	0.39	0.66	O	
1	Altimeter front (m)	United Instr.	UI5934PD-3M A.665	31393	0.39	0.66	A	
1	Altimeter front (ft)	Mikrotechna Praha	LUN 1128.10B6	34159	0.59	0.65	A	
1	Altimeter front (m)	Mikrotechna Praha	LUN 1124.01-8	34160	0.64	0.65	A	
1	Altimeter rear (ft)	United Instr.	UI5934PD-3 A.134	30416	0.39	1.62	R	
1	Altimeter rear (m)	United Instr.	UI5934PD-3M A.665	33652	0.39	1.62	A	
1	Altimeter rear (ft)	Mikrotechna Praha	LUN 1128.10B6	34159	0.59	1.61	A	
1	Altimeter rear (m)	Mikrotechna Praha	LUN 1124.01-8	34160	0.64	1.61	A	
1	Vertical Speed Indicator (fpm)	United Instr.	UI7030 C.27	01485	0.54	1.62	O	
1	Vertical Speed Indicator (m/s)	United Instr.	UI7030-MC.194	33653	0.54	1.62	O	
1	Vertical Speed Ind. (fpm)	Mikrotechna Praha	LUN 1144.B0B1	34161	0.40	1.61	A	
1	Vertical Speed Ind. (m/s)	Mikrotechna Praha	LUN 1144.F0B1	34162	0.40	1.61	A	
1	Attitude Gyro (electronic. 2 1/4")	RC Allen	RCA2600-2 (0° tilt)	33027	0.24	1.63	O	
1	Attitude Gyro (electronic. 2 1/4")	RC Allen	RCA2600-2 (0° tilt) 102-0202-01	33881	0.13	1.61	A	
1	Attitude Gyro (electronic. 3 1/8")	RC Allen	RCA2600-3 (0° tilt)	33217	0.45	1.63	A	
1	Attitude Gyro (electronic. 3 1/8")	RC Allen	RCA2600-3 (0° tilt) 102-0203-01	33882	0.19	1.61	A	
1	Slip Indicator (on RCA 2600)	RC Allen	444-0010-01	33529	0.03	1.63	A	

Reserved

1/1	Slip/Skid Indicator	Rieker	1040	FI0009	0.05	1.60	O	
Optional Primary Flight Display (ASPEN)								
1	Electr. Flight Display (EFD1000)	Aspen	910-00001-001	in 33846, 33291, 34020 & 34021	1.32	1.55	O	
1	Configuration Module (Pilot)	Aspen	920-00004-001	in 33846 & 34020	0.04	1.50	O	
1	Configuration Module (Pro)	Aspen	920-00004-002	in 33291 & 34021	0.04	1.50	O	

QTY	ITEM	MANUFACT.	MODELNO	PART OR P/N	WEIGHT (kg)	ARM (m)	R* A O	INST
1	Remote Sensor Module (RSM) w GPS	Aspen	910-00003-001	in 33846, 33291, 34020 & 34021	0.91	3.95	O	
1	RSM Installation bracket	Extra	EA-86206.10		0.19	3.95	O	
Optional Multi-Function Display (ASPEN)								
1	Electr. Flight Display (EFD1000)	Aspen	910-00001-001	in 33292, 33293, 34024 & 34025	1.32	1.55	O	
1	Electr. Flight Display (EFD500)	Aspen	910-00001-003	in 32956, 33639, 34022 & 34023	1.09	1.55	O	
1	Configuration Module (EFD 1000 MFD)	Aspen	920-00004-004	in 33292, 33293, 34024 & 34025	0.04	1.50	O	
1	Configuration Module (EFD 500 MFD)	Aspen	920-00004-005	in 32956, 33639, 34022 & 34023	0.04	1.50	O	
1	Remote Sensor Module (RSM) w/o GPS	Aspen	910-00003-002	in 33292, 33293, 34024 & 34025	0.91	3.95	O	
Optional Hour Meters								
1	Flight Timer	Winter	FSZM 1510	01605	0.15	1.55	O	
Optional Clock								
1	Digital Clock	Astrotech	LC-2	F10004	0.14	1.60	O	
Optional Aerobatics Equipment								
1	Aresti-Card Holder	Extra	EA-83504.4	EA-83504.004-PG	0.09	1.66	O	
1	Aresti-Card Holder (Aspen)	Extra	EA-86504.4	EA-86504.004-PG	0.09	1.66	A	
1/1	Sighting device (45°/90°)	Extra	EA-8E801.30		0.55	1.60	O	
1	Smoke System	Extra	86112		9.20	0.30	O	
Optional Electronic Accelerometer								
1	El. accelerometer with audio/visual warning	TL Elektronik	TL-3424_EXT	32582	0.30	1.60	O	
Avionics (34 & 23)								
1	VHF-Com	Becker	AR 4201	00652-PG	0.67	1.54	R	
1	VHF-Com (8.33kHz spacing)	Becker	AR 6201	33041	0.85	1.54	A	
1	GPS/COM	Garmin	GNC 420W	32734-PG	2.65	1.54	O	
1	GPS / NAV / COM	Garmin	GNS 430W	32773-PG	2.95	1.54	A	
1	GPS / NAV / COM	Garmin	GNS 530W	28219-PG	3.75	1.49	A	
1	GPS/COM	Garmin	GTN 635	33772-PG	2.82	1.54	A	
1	GPS / NAV / COM	Garmin	GTN 650	33773-PG	3.20	1.54	A	
1	GPS / NAV / COM	Garmin	GTN 750	33774-PG	4.24	1.54	A	
1	COM Antenna	Pointer	P1 3001-10	FE4254	0.05	1.60	R	
1	GPS-Antenna	Garmin	GA 35	32620	0.21	3.90	O	
1	NAV-Antenna	Comant Industries	CI-158C	33035	0.16	3.90	O	

QTY	ITEM	MANUFACT.	MODELNO	PART OR P/N	WEIGHT (kg)	ARM (m)	R* A O	INST
1	Diplexer	Comant Industries	CI507	FA4057	0.09	3.90	O	
1	Course Deviation Ind.	Garmin/Mid Continent	GI-102A	FA3010	0.64	1.54	O	
1	Course Deviation Ind./GS	Garmin/Mid Continent	GI-106A	FA3003	0.64	1.54	O	
1	Transponder (Mode S)	Becker	BXP6401-2-(01)	31860-PG	0.80	1.60	A	
1	Transp. (Mode A&C)	Garmin	GTX 327	FA3009-PG	0.95	1.75	O	
1	Transponder (Mode S)	Garmin	GTX 328	32839-PG	1.50	1.73	A	
1	Transponder (Mode S)	Garmin	GTX 330	30334-PG	1.50	1.73	A	
1	Transponder (Mode S)	Garmin	GTX 33	33775-PG	2.00	3.02	A	
1	Transp. (mode A&C)	Becker	ATC-4401	31002-PG	0.73	1.60	A	
1	Transponder	f.u.n.k.e.	TRT800H	32090	0.60	1.20	A	
1	Blind Encoder Module	Becker	BE-6400-01	32100	1.10	1.39	O	
1	Altitude Blind Encoder (grey code)	ACK	A-30	02239	0.20	1.50	O	
1	Altitude Blind Encoder (serial output)	ACK	A-30.8 (or higher)	32960	0.20	1.50	O	
1	Transponder Antenna	Comant Industries	CI 105	32269	0.11	0.14	O	
1	ELT	Artex	ME 406	32173-PG	1.42	2.60	O	
	ELT Antenna (for Artex)	Artex	110-773	33524	0.08	3.00	O	
1	ELT	KANNAD	406 AF COMPACT	34210	1.11	2.97	A	
1	ELT	KANNAD	406 AF INTEGRA	34422	0.99	2.96	A	
1	ELT Antenna (for Artex or KANNAD)	Rami	AV-200	33965	0.08	3.00	AO	
1	Intercom	Northern Airborne	NAT AA83-001	31659-PG	0.28	1.55	O	
1	Panel Dock	AirGizmos	GPSMAP 696	33665	0.25	1.60	O	
1	Panel Dock	AirGizmos	GPSMAP 796	34175	0.27	1.60	O	
1	Panel Dock	AirGizmos	iPad Mini Panel Dock	34410	0.12	1.62	O	
1	Remote Audio Panel	Garmin	GMA 35	33902-PG	1.00	1.53	O	
Cowling (54)								
1	Cowling (CRP)	Extra	EA-83001.0		9.20	-0.57	R	
1	Cowling (GRP)	Extra	EA-83003.0		10.60	-0.57	A	
1	Cowling (CRP, incl. Landing Light provision)	Extra	EA-8E001.0		9.20	-0.57	A	
Canopy (56)								
1	Standard Canopy	Extra	26301.000-LV	26301.000-VF	13.50	1.69	R	
1	Single Seat Canopy	Extra	EA-86411.0	86411.001-VF	13.20	1.69	A	
Propeller (61)								
1	3-Blade Propeller	MT-Propeller	MTV-9-B-C/ C198-25	32285	30.50	-1.15	R	
1	Spinner	MT-Propeller	P-810-2	31415	0.80	-1.20	R	
1	4-Blade Propeller	MT-Propeller	MTV-14-B-C/ C190-130	33970	30.60	-1.15	A	
1	Spinner	MT-Propeller	P-967	31560	0.80	-1.20	A	

QTY	ITEM	MANUFACT.	MODELNO	PARTOR P/N	WEIGHT (kg)	ARM (m)	R* A O	INST
1	Governor (max 2600 RPM)	MT-Propeller	P-880-41	32941	1.10	-0.91	R	
1	Governor (max 2700 RPM)	MT-Propeller	P-880-5	31509	1.10	-0.91	A	
1	Governor (max 2700 RPM)	Woodward	A-210988	01209	1.10	-0.91	A	
Powerplant (7X)								
Engine								
1	Engine	Lycoming	AEIO-580-B1A (R/H)ENPL-RT10427	32712	191.72	-0.72	R	
4	Shock Mount	Barry	94016-02	01817	1.70	-0.29	R	
*	Fuel. Oil. Sense Lines in Eng. Comp.	Parker/Statoflex	PTFE Type 101	33592	3.40	-0.15	R	
Engine Fuel System								
1	Fuel Injector	Precision/Avstar	RSA 10 AD 1	61M26404	3.90	-0.68	R	
1	Mech. Fuel Pump	Crane Lear Romec Hartzell Engine Tech.	RG9080-J4A PN 200F-5002	62E22581 62E23186	0.57 0.57	-0.30 -0.30	R A	
Ignition								
1	Ignition Switch	TCM	10-357200-1	00185	0.15	1.63	R	
1	Magneto. LH	Slick	6393	32860	2.30	-0.15	R	
1	Magneto. RH	Slick	6350	02337	2.00	-0.15	R	
1	Slick Start; Magneto Start Booster	Unison	SS1001	32598	0.27	-0.02	R	
Engine Controls								
1	RPM Vernier Control	ACS Products Co.	A-750-30-1200	00113	0.71	0.82	R	
1	Mixture Vernier Control	ACS Products Co.	A-750-20-1080	00112	0.65	0.94	R	
1	Throttle Control	Teleflex	CC330 10	33052	0.56	0.60	R	
1	Throttle Control Cable	Cablecraft	580-540-501	33589	0.60	0.60	A	
Engine Indicating (77)								
Conventional engine gauges								
1	RPM Indicator digital (max 2600 RPM)	Horizon	P100-230-635-00	33624	0.68	1.60	R	
1	RPM Indicator digital (max 2700 RPM)	Horizon	P100-230-643-00	02489	0.68	1.60	A	
1	Oil Press / Oil Temp Ind. (2 1/4")	UMA	D2-OP130U-OT300U-01	33428	0.09	1.62	R	
1	Oil Temp. Sender	UMA	1B3A		0.08	-0.11	R	
1	Oil Press Sensor	UMA	N1EU150G(-A) or T1EU150G(-A)		0.12	0.04	R	
1	Manifold Pressure / Fuel Flow Ind.	United Instr.	UI6331-H.217	03247	0.49	1.60	R	
1	Fuel Qty. Ind. Wing	VDO	301 030 001 G	200171	0.14	1.62	R	
1	Fuel Qty. Ind. Fuselage Tank	VDO	301 030 002 G	00390	0.14	1.62	R	

QTY	ITEM	MANUFACT.	MODELNO	PART OR P/N	WEIGHT (kg)	ARM (m)	R* A O	INST
1	EGT/CHT Indicator	UMA	D2-ET1K7K-CT600J-01	33438	0.07	1.62	R	
1	EGT Probe	UMA	2BU20		0.06	-0.37	R	
1	CHT Probe	UMA	2B18 or 2B02		0.05	-0.20	R	
Optional add on to convert eng. Gauges								
1	Fuel Scan Sys.	JPI	FS-450	30611-PG	0.18	0.98	O	
1	Fuel Flow Transducer	Flowscan Shadin	201-B or FXT-201 680501 or 680600	FI4015	0.09 0.09	-0.02 -0.02	O A	
1	Engine Monitor Sys.	JPI	EDM700/800	31530-PG	1.39	0.50	O	
6	EGT Probe	JPI	M-111		0.35	-0.57	O	
6	CHT Probe	JPI	M-113 (S-Plug Gask.)		0.26	-0.56	O	
1	OAT Probe	JPI	400510		0.05		O	
1	Oil Temp Probe	JPI	400500-L		0.05	-0.22	O	
1	Manifold Press. Probe	JPI	604010		0.05	1.55	O	
1	RPM Probe	JPI	420809		0.05	-0.11	O	
1	Fuel Flow Transducer	Flowscan Shadin	201-B or FXT-201 680501 or 680600	FI4015	0.09 0.09	-0.02 -0.02	O A	
Option Integrated Engine Instrument System								
1	Engine Instr. Display	Electronics Intern.	MVP-50P-EX-03	34393	0.86	1.55		O
1	Engine Instr. Display	Electronics Intern.	MVP-50P-EX-04	34394	0.86	1.55		A
1	Engine Data Converter	Electronics Intern.	EDC-33P	33283	1.00	0.42		O
1	Fuel Flow Transducer	Electronics Intern.	FT-60	33288	0.78	-0.57		O
6	EGT Probes	Electronics Intern.	P-110	33569	0.26	-0.72		O
6	CHT Probes	Electronics Intern.	P-100	33568	0.16	-0.72		O
1	Oil Temp Probe	Electronics Intern.	P-120	33289	0.02	-0.09		O
1	OAT Probe	Electronics Intern.	P-128	33290	0.02	0.77		O
1	Man. Press. Transducer	Electronics Intern.	PT-30ABS	33284	0.11	0.25		O
1	Oil Pressure Transducer	Electronics Intern.	PT-100GA	33286	0.05	0.05		O
1	Fuel Press. Transducer	Electronics Intern.	PT-30GA	33285	0.05	0.05		O
1	Resistive Fuel Level Mod.	Electronics Intern.	RFLM-4-12V	33109	0.20	0.31		O
Exhaust (78)								
1	Exhaust System "6 in 1" (incl. silencer) with 2" inlet/outlet cooling shroud	Gomolzig	EA300-606000	33891	8.48	-0.39	R	
1		Gomolzig	EA300-606009	32153				
1	Exhaust System "6 in 1" (incl. silencer) with 3" inlet/outlet cooling shroud for heating system	Gomolzig	EA300-606000	33891	8.48	-0.39	A	
1		Gomolzig	EA300-606024	03248				
Oil System (79)								
1	Single Oilcooler rear	Aero Classics	8000353	31417	1.65	-0.22	R	
1	Low Temperature Breather Line Kit	Extra	EA-83301	300 Option cold weather kit	0.20	-0.01	A	
Starting (80)								
1	Starter Flyweight	Sky-Tec	149-12LS	32865	3.74	-0.85	R	

Left blank intentionally

SECTION 7
DESCRIPTION & OPERATION OF AIRCRAFT AND SYSTEMS

Table of Contents

<i>Paragraph</i>		<i>Page</i>
7.1	THE AIRCRAFT	7-3
7.2	FUSELAGE	7-3
7.3	WINGS	7-4
7.4	EMPENNAGE	7-4
7.5	FLIGHT CONTROL SYSTEM	7-5
7.5.1	Primary Control System	7-5
7.5.2	Longitudinal Flight Control System	7-5
7.5.3	Lateral Flight Control System	7-5
7.5.4	Directional Flight Control System	7-5
7.5.5	Secondary Control	7-5
7.6	INSTRUMENTATION	7-5
7.6.1	Instrument Panel (Rear Cockpit)	7-6
7.6.2	Instrument Panel (Front Cockpit)	7-8
7.7	LANDING GEAR	7-8
7.8	SEATS, SEAT BELTS	7-8
7.9	CANOPY	7-8
7.10	POWER PLANT	7-9
7.10.1	Engine	7-9
7.10.2	Oil System	7-9
7.10.3	Engine Installation	7-10
7.10.4	Propeller	7-10
7.10.5	Throttle	7-10
7.10.6	Mixture	7-10
7.10.7	RPM-Control	7-10
7.10.8	Fuel Selector Valve	7-10
7.10.9	Exhaust System	7-10
7.11	FUEL SYSTEM	7-10
7.12	ELECTRICAL SYSTEM	7-12
7.13	CABIN ENVIRONMENT CONTROL	7-12

Left blank intentionally

SECTION 7

**DESCRIPTION AND OPERATION
OF AIRCRAFT AND SYSTEMS**

7.1 THE AIRCRAFT

The aircraft EXTRA 330LX is designed and developed by EXTRA Flugzeugproduktions- und Vertriebs- GmbH, Flugplatz Dinslaken, 46569 Hünxe, Federal Republic of Germany, in accordance with the U.S. Federal Aviation Regulations, part 23, categories normal and acrobatic to fulfill the primary flight training, normal operation rules and acrobatic training up to the unlimited acrobatic level.

EXTRA 330LX is a light weight, robust, single piston-engined, two-seat aircraft with a fuselage structure in tig-welded steel-tube construction.

The landing gear, wing, and tail are made of epoxy, reinforced with glass- and carbonfiber. The items are qualified up to 72°C (161,6°F). Not to exceed this temperature limit an appropriate colour specification for composite structure is given by the manufacturer document EA-03205.19.

To check the temperature inside the cockpit (potential "green house" effect) a reversible temperature indicator (*STRUCTURAL OVERHEAT INDICATOR*) is applied on the wing main spar in the carry-through section. After reaching the temperature limit of 72°C (161,6°F) the word "RISK" appears on the red spot of this structural overheat indicator immediately and flying is prohibited. When the structure cools down below this temperature limit the word "RISK" disappears and you may go on with the preflight checklist.

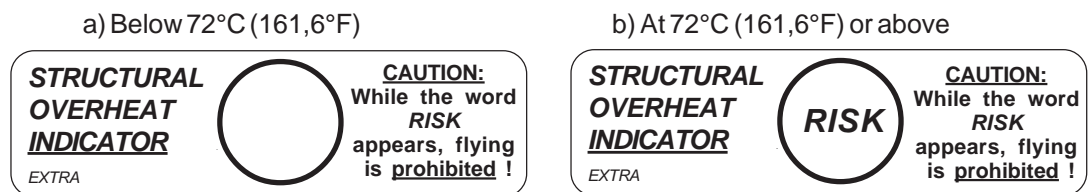

The standard aircraft is designed to operate within a range of ambient air temperature from -20°C to +44°C (-4°F to 111°F) at sea level. It is possible to start the engine using the aircraft battery at -20°C (-4°F) without preheating. Below -10°C (+14°F) OAT a special oil breather line must be adapted (available as kit).

7.2 FUSELAGE

The fuselage structure consists of a steel tube construction integrating the wing and empennage connections as well as the seats. The fuselage except the rear lower part, is faired with an aramid/carbon laminate shell. Within the exhaust area stainless steel sheet metal is used. The upper fuselage body surface is one part from firewall to vertical stabilizer including the correlated canopy frame. Only the lower rear part of the fuselage is covered with Ceconite® 102.

The canopy frame itself is constructed by carbon laminate. The canopy is one part, opens to the right and is held in the open position by a belt. Emergency jettisoning is achieved by simply unlatching the canopy. For additional pilot protection a roll bar is installed behind the rear pilots seat.

7.3 WING

The wing is a CRP construction. The dual chamber main spar - being a fail safe design - consists of carbon roving caps combined with CRP webs. Core foam is a PVC foam. The wing shell is built by a Honeycomb sandwich with CRP laminates. Wing box ribs are made of carbon fiber composite with honeycomb core. The ribs in the nose section are made of wood. The connection to the fuselage is arranged by two bolts piercing through the spar parallel to the centerline of the fuselage and two brackets at the rear spars.

The ailerons are supported at four points in spherical bearings. In addition the aileron tip has a shielded horn balance.

The hinge line of the ailerons is positioned 25% of the aileron chord. Furthermore the ailerons are equipped with "spades" to decrease pilot's forces. The aileron control push-pull rods are connected to the aileron at the second bearing point (in span-wise direction). To prevent flutter the ailerons are mass balanced at the leading edge of the shielded horn.

7.4 EMPENNAGE

The EXTRA 330LX possesses a cruziform empennage with stabilizers and moveable control surfaces. The rudder is balanced aerodynamically at the tip. Spars consist of PVC foam cores, CRP caps and CRP laminates. The shell is built using honeycomb sandwich with CRP laminates.

Deviating from the other control surfaces the spar webs of the surfaces of the elevator is built by CRP. On the R/H elevator half a trim tab is fitted with two hinges. The control surfaces are mounted in spherical bearings (exception: trim tab). To prevent flutter rudder and elevator are mass balanced. The balance weight for the rudder is installed in the nose of the rudder horn while the balance weights for the elevator are mounted near the outside elevator tips and in the center position.

7.5 FLIGHT CONTROL SYSTEM

7.5.1 PRIMARY CONTROL SYSTEM

The EXTRA 330LX is standard equipped with full dual primary flight controls including front and rear sticks and adjustable rudder pedals. The primary control surfaces are operated through a direct mechanical linkage.

7.5.2 LONGITUDINAL FLIGHT CONTROL SYSTEM

Front and rear sticks are interconnected by a push rod inside the torque tube. From there the control movements are transferred to the elevator by two additional push rods.

7.5.3 LATERAL FLIGHT CONTROL SYSTEM

Push and pull rods are connected by sealed ball bearings from the torque tube to the ailerons.

The ailerons are statically as well as dynamically balanced (dynamically with spades).

The ailerons are supported by lubricated, sealed bearings.

7.5.4 DIRECTIONAL FLIGHT CONTROL SYSTEM

The dual rudder pedals with brake pedals are electric adjustable and operate the rudder through a cable system. Springs keep the cables under tension when they are not operated.

7.5.5 SECONDARY CONTROL

The elevator trim tab is actuated by an electric trim servo located in the right rear fuselage. It is controlled by a trim switch integrated in the control stick handle or in the instrument panel. Trim position is indicated by a LED indicator on the instrument panel.

7.6 INSTRUMENTATION

The Extra 330LX is equipped with flight instruments in both cockpits.

Instruments and placards can be provided with markings in either metric or English units. The colour markings in instruments follow US-FAR, part 23 recommendation (see section 2).

7.6.1 INSTRUMENT PANEL (REAR COCKPIT)

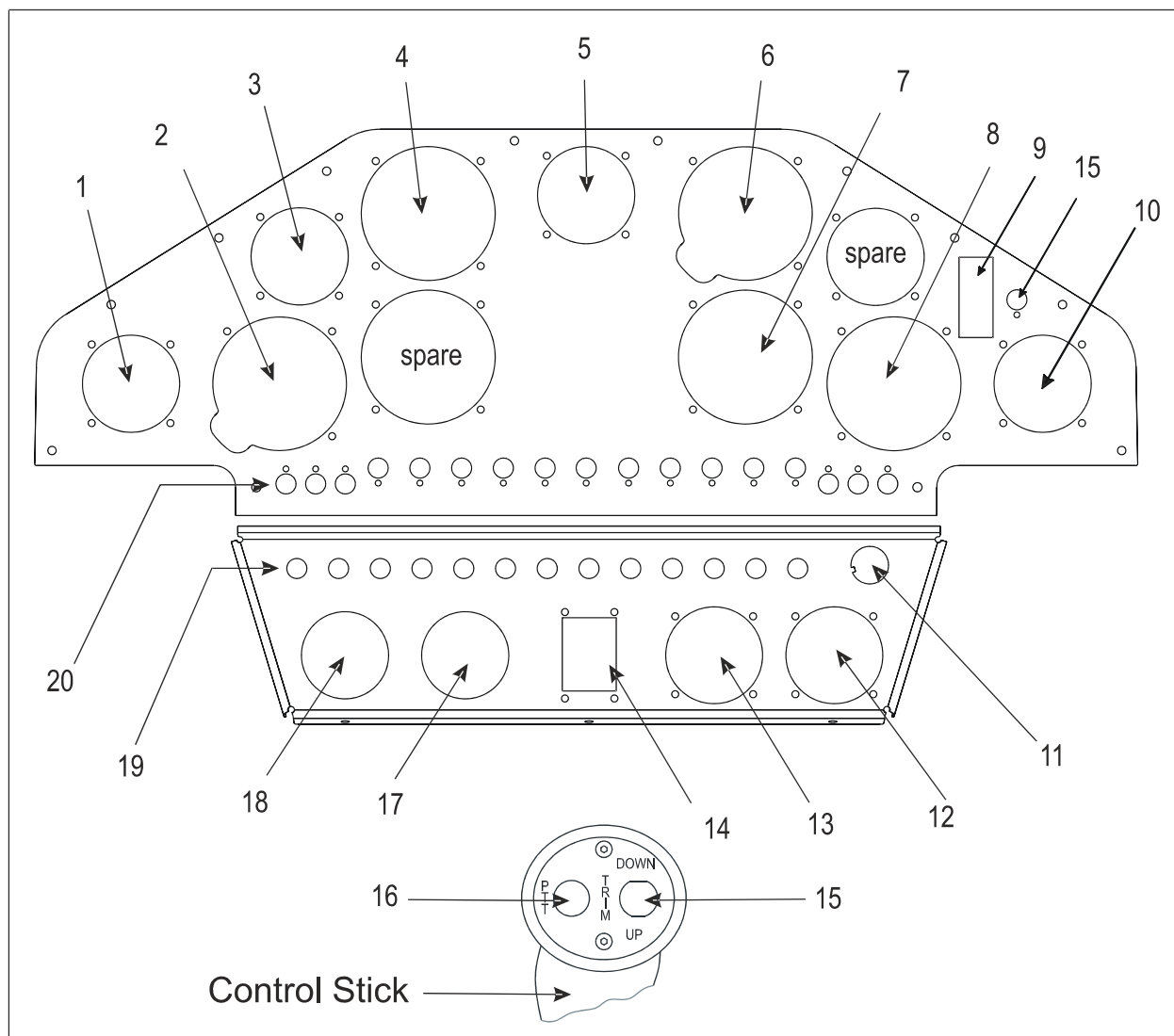

Figure 1, Instrument Panel

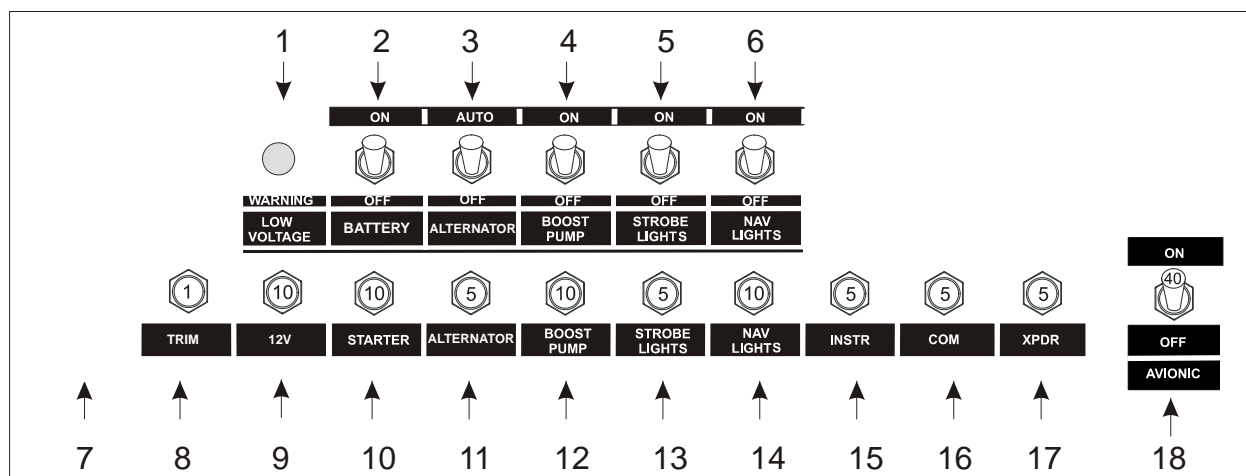

Figure 2, Switches, Circuit Breaker

Position Fig. 1	Item
1	COM
2	G-meter
3	Volt/Amperemeter
4	Airspeed indicator
5	Magn. direction indicator
6	Altimeter
7	Manifold pressure / fuel flow
8	RPM Indicator
9	Trim position indicator
10	Transponder
11	Magneto selector switch and starter
12	Oil pressure / oil temperature
13	EGT / CHT
14	Fuel quantity center tank
15	Trim switch (different positions possible)
16	PTT switch
17	Fuel quantity center tank
18	Fuel quantity wing tank
19	Circuit breaker
20	Switches

Position Fig. 2	Item
1	Alternator warning light incl. press-to-test feature
2	Battery switch (red cap)
3	Alternator switch (red cap)
4	Boost pump switch
5	Strobe lights switch
6	NAV lights switch
7	Reserved
8	Trim circuit breaker
9	12 V circuit breaker
10	Starter circuit breaker
11	Alternator circuit breaker
12	Boost pump circuit breaker
13	Strobe lights circuit breaker
14	NAV lights circuit breaker
15	Instruments circuit breaker
16	COM circuit breaker
17	Transponder circuit breaker
18	Avionic switch/circuitbreaker

NOTE

This list may be modified by the minimum equipment requirements of individual certifying authorities!

7.6.2 INSTRUMENT PANEL (FRONT COCKPIT)

Normally the instrument panel in the front cockpit is only equipped with:

- Airspeed indicator
- Altimeter indicator.

7.7 LANDING GEAR

The landing gear is a composite construction with a multichamber fiberglass spring in a tail-wheel design.

The main wheels have a size of 5-5.50 and they are equipped with hydraulic disc brakes.

To reduce aerodynamic drag carbonfiber wheel fairings are installed. They feature a submerged air intake for brake disc cooling and a small hatch to reach the valve of the wheel tube for inflation.

The tail wheel has a solid rubber tire with full-swivel capability.

7.8 SEATS, SEAT BELTS

The seats are ergonomically shaped composite designs. The rear seat angle can be adjusted on the ground with 2 quickpins, there are different seat angle possibilities. The back rest is also adjustable on the ground in different positions and angle. The rear pedal-to-seat distance can be varied in different positions. In the front cockpit there is no possibility to adjust either the pedals nor the seat. The seat belt assembly consists of a left and a right shoulder strap, two left and two right lap belts and a negative-g-strap. All belts are adjustable. As each lap belt features a single point release, they are redundant for safety during aerobatic maneuvers. If one release is opened unintentionally, the second one guarantees full safety. For safe operation the releases are arranged in a way that one has to be closed to the right side, the other one to the left. During acrobatic maneuvers the seat belt system should be tightened firmly.

7.9 CANOPY

The canopy is manufactured in one section and can be manually operated by interior locking handles located on the left side on the canopy.

To open the canopy from inside proceed as follows:

Pull together the interior locking handles of the front or rear seat and lift canopy to the right.

The canopy strap will limit the opening angle.

To lock the canopy pull together the interior locking handles and then release.

To open the canopy from the outside use the aft interior handles by reaching through the small window (bad weather window) and proceed as mentioned above.

Generally the emergency operation is equal to the normal procedure. When opening the canopy in normal flight the low pressure over the canopy will flip the canopy fully open immediately. However complete jettison of the canopy is possible. In this case the canopy can be finally unlatched at its RH hinge line by the following action:

push canopy slightly forward while opening.

7.10 POWER PLANT

7.10.1 ENGINE

The power plant consists of one Textron-Lycoming six-cylinder, horizontally opposed, aircooled, direct drive, fuel injection engine type with inverted oil system.

The AEIO-580-B1A engine is characterized by the following performance data:

- Rated power at 2700 RPM: 315 HP (234.9 kW).
- Rated power at 2600 RPM: 303 HP (225.9 kW).
- Rated power at 2400 RPM: 286 HP (213.3 kW).

The engine is equipped on the left side with a retard type magneto. This magneto has a retard breaker providing a fixed retard and long duration boosted spark for starting. A Slick Start System completes the installation.

For the present TBO refer to latest issue of Textron - Lycoming SERVICE LETTER No. L 201.

The AEIO-580-B1A engine is equipped with special antivibration counterweights.

The following accessories are included in the power plant installation:

- Fuel Injector:
- Magnetos/Start System:
- Alternator:
- Starter:
- Fuel pump:
- Shielded ignition system
- Propeller governor drive

The engine is operated with the following manual controls:

- Throttle control, dual
- RPM control
- Fuel mixture control

The starter/magneto switch is located on the right side of the instrument panel in front of the rear seat.

The propeller governor monitors the RPM automatically and prevents overspeeding. In the event that oil pressure is lost the propeller is automatically adjusted to coarse pitch in order to avoid overspeeding.

The use of 100/130 aviation grade fuel (AVGAS 100) is the minimum grade recommended by the manufacturer of the AEIO-580-B1A engine.

For continuous operation 115/145 aviation fuel is the maximum grade.

7.10.2 OIL SYSTEM

The oil is cooled by a Single Cooler System. The oil cooler is mounted on the aft, right hand side of the engine. The oil level is determined by a dip-stick.

A thermostatic valve is fitted upstream of the oil cooler. This valve ensures a quick warm-up of the oil after engine start.

For oil capacities, temperatures and grades refer to Section 1.7.

7.10.3 ENGINE INSTALLATION

The engine is supported by four shock mounts (type BARRY CONTROLS), to the tig-welded steel tube engine mount which is attached to the fuselage with four bolts on the firewall axis. The engine cowling is divided into two parts, a lower and an upper part both made of glass-fibre/carbonfibre reinforced epoxy. The parts are fixed by a number of screws and the upper cowling has a separate hatch for easy access to the oil dip-stick.

7.10.4 PROPELLER

The standard propeller is a 3-blade wood composite, constant speed MTV-9-B-C/C 198-25 type propeller having a diameter of 1.98 m (77.95 in).
Alternatively a 4-blade constant speed MTV-14-B-C/C190-130 propeller can be installed. This propeller has a diameter of 1.90 m (74.8 in).

7.10.5 THROTTLE

Dual control (cub-type) mounted on the left side of the cockpit.

7.10.6 MIXTURE

Vernier-control located at the left side of the rear cockpit (red knob).

7.10.7 RPM-CONTROL

Vernier-control on the left side of the rear cockpit.
Preselection of RPM possible due to constant speed governor (blue knob).

7.10.8 FUEL SELECTOR VALVE

Dual control. A rotary fuel selector valve is mounted behind the firewall on the right side of the fuselage. A torque tube connects the valve to both cockpit handles. Pull and turn the handle 90° to open the valve to the Acro & Center Tank. A further 90° turn switches to the Wing Tank fuel supply.

Position down = CLOSED
Position left = ACRO & CENTER TANK
Position up = WING TANK

7.10.9 EXHAUST SYSTEM

A complete Gomolzig 6 in 1 System with integrated silencer is installed on the 330LX.

7.11 FUEL SYSTEM

The fuel system (refer to Figure 3) consists of two separate, independent tanks:
- Acro & center tank in the fuselage
- Wing tank (LH and RH)

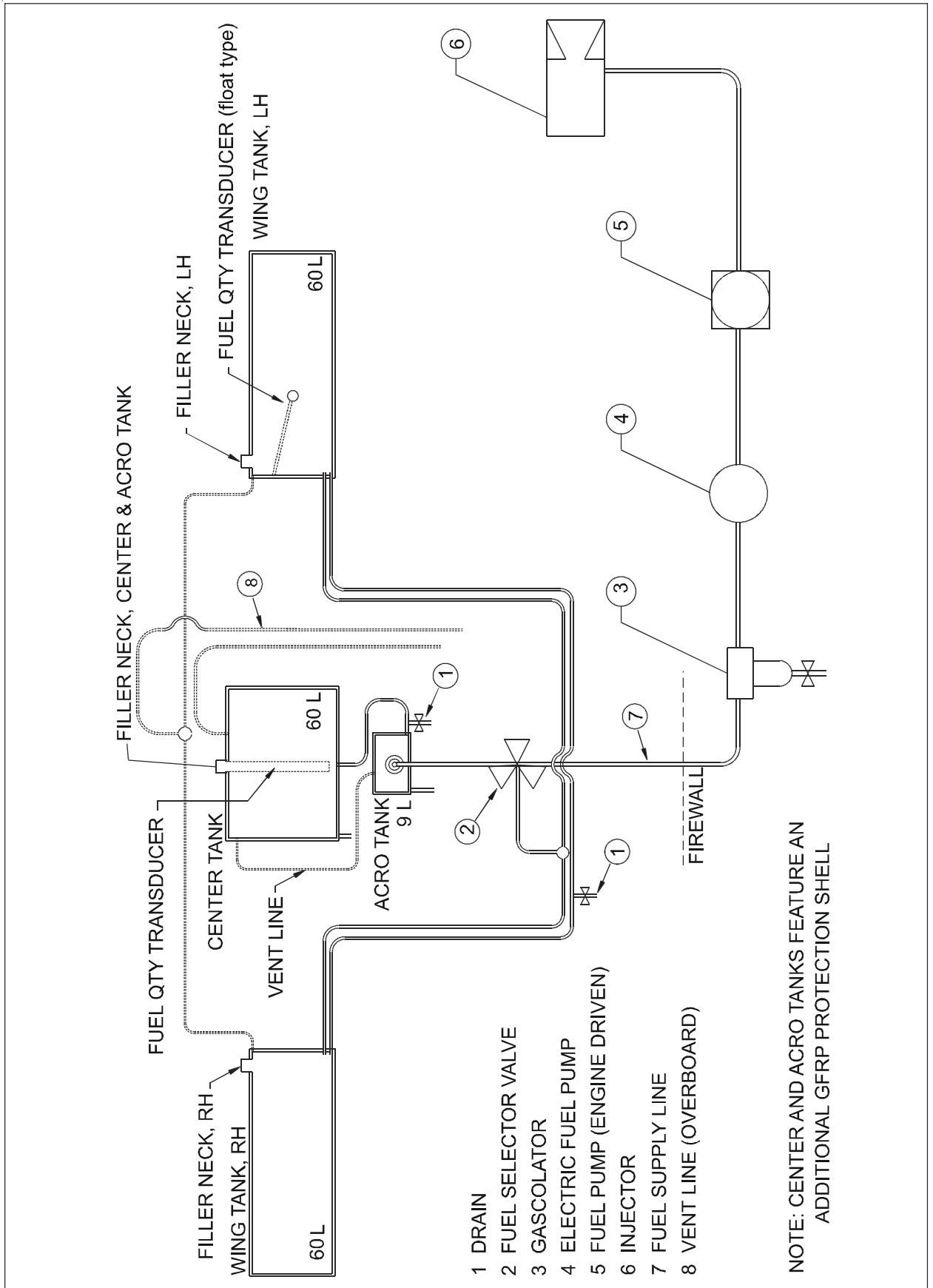

Figure 3, Fuel System

Wing Tank:

The root section of each wing - in front of main spars forms an integral fuel tank providing two interconnected tanks with 120 liters (31,7 US GAL.) total capacity. Each side of the wing has a 2" diameter filler cap for gravity refueling. The wing tank can be completely emptied in flight.

Acro & Center Tank:

An Acro tank 9 liters (2,3 US Gal.) is mounted in the fuselage just behind the firewall and the Center tank 60 liters (15.9 US Gal.) in front of the main spar of the wing. The Acro tank is connected with the center tank in a gravity feed system. The center tank has a 2" diameter filler cap for gravity refueling. Unusable fuel is 2 liters (0.5 US Gal.).

Adequate venting is provided in each tank to a main ventilation-tube, ending outside the fuselage at the right side.

In addition to the engine driven fuelpump an electrically driven auxiliary fuel pump (boost pump) with by-pass and having sufficient capacity to feed the engine at take-off power is fitted as a safety device against failure of the engine-driven pump. The boost pump switch is located on the instrument panel.

A fuel filter with drain is installed between the fuel selector valve and the boost pump.

Separate drains are located at the lowest point of each tank system.

Normal float type transducers and electrically operated fuel indicators are used.

7.12 ELECTRICAL SYSTEM

The electrical system (refer to Figure 4) is supplied by a 12 V alternator with integrated rectifier, transistor voltage regulator. The alternator is mounted on and belt-driven by the engine.

The field current is controlled by the voltage regulator to nominal 14.5 V under all load conditions. The ALTERNATOR switch is located on the rear instrument panel.

Circuit protection against overvoltage is provided by the voltage regulator.

Depending on the alternator installed the maximum alternator output varies from 55 to 65 A. Refer to the Equipment List in Section 6 for identification of alternator installed.

A 12 V leak proof battery is connected across the alternator output to stabilize the supply and to maintain all essential services in the event of an alternator failure and when the engine is not operating. The battery is mounted behind the firewall. The BATTERY switch is located on the rear instrument panel.

All electrical circuits are protected by circuit breakers located on the rear instrument panel and they are easily accessible to the pilot during flight.

The electrical system features adequate noise suppression to ensure satisfactory operation of the radio equipment.

All wires, switches, circuit breakers etc. are manufactured to related aeronautical specifications.

7.13 CABIN ENVIRONMENT CONTROL

A ventilation system in the canopy on the left side is provided for the supply of fresh air to the cabin. Left and right at the rear seat are eyeball-type adjustable vents.

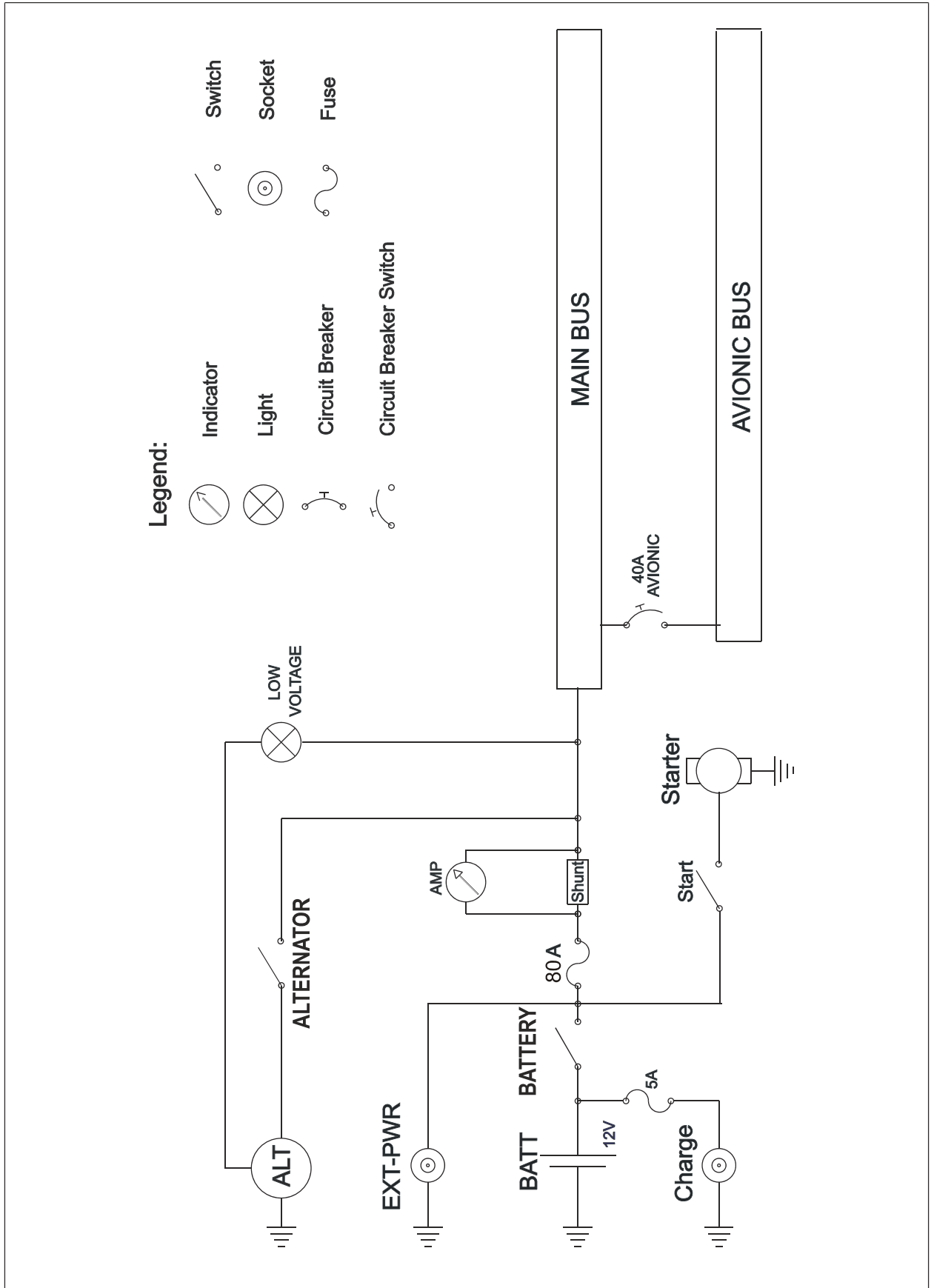

Figure 4, Electrical System

Left blank intentionally

SECTION 8
HANDLING, SERVICING & MAINTENANCE

TABLE OF CONTENTS

<i>Paragraph</i>		<i>Page</i>
8.1	INTRODUCTION	8-3
8.2	AIRPLANE INSPECTION PERIODS	8-3
8.3	PILOT CONDUCTED PREVENTIVE MAINTENANCE	8-3
8.4	ALTERATIONS OR REPAIR	8-3
8.5	SERVICING	8-4
8.6	GROUND HANDLING	8-4

Left blank intentionally

SECTION 8

HANDLING, SERVICING AND MAINTENANCE

8.1 INTRODUCTION

- a) The airplane owner should establish contact with the dealer or certified service station for service and information.
- b) All correspondence regarding the airplane must include its serial number which is stamped on a plate on the L/H rear part of the fuselage.
- c) A service manual with revision service may be procured from the manufacturer.

8.2 AIRPLANE INSPECTION PERIODS

As required by national operating rules all airplanes must pass a complete annual inspection every twelve calendar months. In addition to the annual inspection airplanes must pass a complete inspection after every 100 flights hours with a minor check after 50 hours.

The Airworthiness Authority may require other inspections by the issuance of airworthiness directives applicable to the aircraft, engine, propeller and components. The owner is responsible for compliance with all applicable airworthiness directives and periodical inspections.

8.3 PILOT CONDUCTED PREVENTIVE MAINTENANCE

Pilots operating the airplane should refer to the regulations of the country of certification for information of preventive maintenance that may be performed by pilots. All other maintenance required on the airplane is to be accomplished by appropriately licensed personnel. Airplane dealer should be contacted for further information

Preventive maintenance should be accomplished with the appropriate service manual.

8.4 ALTERATIONS OR REPAIR

Alterations or repairs of the airplane must be accomplished by licensed personnel.

8.5 SERVICING

In addition to the airplane inspection periods (8.2) information for servicing the aircraft with proper oil and fuel is covered in Section 2 (Limitations) and Section 7 (Description and Operation).

8.6 GROUNDHANDLING

a) Due to its low weight and the free swiveling tail wheel two persons can easily move the airplane by hand.

b) To tie down the airplane ring plates are provided at the wing tips. The tail wheel leg can be used as third point to tie down the airplane.

If the aircraft is parked in the open, it must be protected against the effects of weather, the degree of protection depending on severity of the weather conditions and the expected duration of the parking period. When the airplane is parked in good weather conditions for less than a half day park the aircraft headed into the wind and place wheel chocks at the main wheels.

c) To level the aircraft, the tail wheel is placed on a balance and jacked to such a position that the fuselage reference line (upper fuselage stringer tube) is horizontal. There are two engine hoists provided on the top of the engine which can be used to lift the airplane with a crane. (Tail wheel resting on ground)

SECTION 9

SUPPLEMENTS

Doc-No. EA-0E701.1

Table of Contents

<i>Section</i>		<i>Pages</i>
9	Supplements	4 p.
901	<input type="checkbox"/> Steerable Tail Wheel	4 p.
902	<input type="checkbox"/> Electric Pedal Adjustment	4 p.
903	<input type="checkbox"/> Cabin Heating System	4 p.
904	<input type="checkbox"/> Accelerometer TL-3424_EXT	6 p.
905	<input type="checkbox"/> External Power	4 p.
906	<input type="checkbox"/> Digital RPM Indicator	6 p.
907	<input type="checkbox"/> Smoke System	8 p.
908	<input type="checkbox"/> Single Seat Canopy	4 p.
909	<input type="checkbox"/> ARTEX ME-406 ELT	8 p.
910	<input type="checkbox"/> NAT AA83-001 Intercom	8 p.
911	<input type="checkbox"/> BECKER ATC 4401 Transponder	8 p.
912	<input type="checkbox"/> BECKER BXP 6401 Transponder	12 p.
913	<input type="checkbox"/> GARMIN GTX 327 Transponder	6 p.
914	<input type="checkbox"/> GARMIN GTX 328 Transponder	8 p.
915	<input type="checkbox"/> GARMIN GTX 330 Transponder	8 p.
916	<input type="checkbox"/> GARMIN GNC 420W/GNS 430W	8 p.
917	<input type="checkbox"/> ASPEN EFD1000/500 System	12 p.
918	<input type="checkbox"/> EI MVP-50P	6 p.
919	<input type="checkbox"/> Landing Light	4 p.
920	<input type="checkbox"/> Airtow Hook	8 p.
921	<input type="checkbox"/> AIRPLANES REGISTERED IN BRAZIL AND OPERATING UNDER THE AGÊNCIA NACIONAL DE AVIAÇÃO CIVIL REQUIREMENTS	6 p.
922	<input type="checkbox"/> GARMIN GTN 635/650/750	16 p.

923	<input type="checkbox"/>	f.u.n.k.e. TRT800H Transponder	10 p.
924	<input type="checkbox"/>	KANNAD 406 AF COMPACT/INTEGRA ELT	8 p.

9 SUPPLEMENTS

9.1 Introduction

Section 9 "Supplements" of the Pilot's Operating Handbook contains all information, necessary for a safe and efficient operation of the airplane when equipped with one or more of the various optional systems and equipment not provided with the standard airplane.

9.2 Notes

The described systems and equipment are certified by the EASA for the EXTRA 330LX. Pages and contents of this section must not be exchanged and alterations of or additions to the approved contents must not be made without the EXTRA Flugzeugproduktions- und Vertriebs-GmbH/EASA approval. The editor has the copyright of these Supplements and is responsible for edition of revisions. The log of effective pages is found on the preceding pages of this Pilot's Operating Handbook.

Each Supplement section (e.g. steerable tailwheel) covers only a single system, device, or piece of equipment and is a self-contained, miniature Pilot's Operating Handbook. The owner is responsible for incorporating prescribed amendments and should make notes about these on the records of amendments. It is responsibility of the pilot to be familiar with the contents of relevant supplements.

POH Supplements must be in the airplane for flight operations when the subject equipment is installed or special operations are to be performed.

The Table of Contents shows all EXTRA Supplements available for the EXTRA 330LX. A check mark in the *Section* column indicates that the corresponding supplement must be included in this POH.

Left blank intentionally

**SECTION 901
STEERABLE TAIL WHEEL**

Table of Contents

<i>Paragraph</i>		<i>Page</i>
901.1	GENERAL	901-3
901.2	LIMITATION	901-3
901.3	EMERGENCY PROCEDURES	901-3
901.4	NORMAL PROCEDURES	901-3
901.5	PERFORMANCE	901-3
901.6	WEIGHT AND BALANCE	901-3
901.7	DESCRIPTION OF THE SYSTEM	901-3
901.8	HANDLING, SERVICING AND MAINTENANCE	901-4

Left blank intentionally

901 STEERABLE TAIL WHEEL

901.1 GENERAL

To improve taxi and handling quality, the EXTRA 330LX can be equipped with an optional steerable tailwheel. The deflection angle of this tailwheel is arranged by the rudder control up to plus/minus 30°. Exceeding this deflection the tailwheel has a full-swivel capability by a release mechanism.

901.2 LIMITATION

The operation limitations are not effected due to the use of the steerable tailwheel.

901.3 EMERGENCY PROCEDURES

There is no change of basic emergency procedures with the installation of the steerable tailwheel.

901.4 NORMAL PROCEDURES

There are no changes for the described normal procedures after installation of the steerable tailwheel. In addition to the existing normal procedures the light precompression of connector springs and movement of the rudder have to be checked during the preflight check.

901.5 PERFORMANCE

Changes in flight performance due to installation of the steerable tailwheel are not noticeable. The given basic performance data under section 5 are still valid.

901.6 WEIGHT AND BALANCE

A change of the running empty weight and resulting C/G position after installation of the steerable tailwheel is neglectable, because of minor differences in weight and C/G between standard and optional steerable tailwheel.

901.7 DESCRIPTION OF THE SYSTEM

The 5 inch tailwheel has a solid rubber tire and is rotatable by means of a wheelfork, which is connected to a bearing steelsleeve. This steelsleeve itself contains also the release mechanic, which gives the wheelfork a full-swivel capability exceeding plus/minus 30° deflection. The steelsleeve is glued into the glasfiberspring, which is bolted to the tail hardpoint of the aircraft. The steering of the tailwheel is accomplished by a direct mechanic link (rudder control cable) from the rudder pedals. The steering deflection of the tailwheel is controlled by the rudder movement and dampened by anti shimmy connector springs.

901.8 HANDLING, SERVICING AND MAINTENANCE

During 50 hour inspection, the bearing steel sleeve has to be lubricated on the point of lubricating. Additionally all parts of the tailwheel have to be inspected visually for deformations, cracks and corrosion.

SECTION 902
ELECTRIC PEDAL ADJUSTMENT

Table of Contents

<i>Paragraph</i>		<i>Page</i>
902.1	GENERAL	902-3
902.2	LIMITATIONS	902-3
902.3	EMERGENCY PROCEDURES	902-3
902.4	NORMAL PROCEDURES	902-3
902.5	PERFORMANCE	902-3
902.6	WEIGHT AND BALANCE	902-3
902.7	DESCRIPTION OF THE SYSTEM	902-4
902.8	HANDLING, SERVICING AND MAINTENANCE	902-4

Left blank intentionally

902.7 DESCRIPTION OF THE SYSTEM

The electrical pedal adjustment system consists of a foot rest and the rudder pedal itself, including brake pedal and brake cylinder. An S-shaped cable leader is attached to the rudder pedal, through which the control cable runs from the rudder actuator arm to the front cable attachment at the steel frame. The connection to the front seat pedals is realized by a further cable, which is fixed to the control cable by two Nicopress oval sleeves. The stepless pedal adjustment is realized by electromechanical actuators which are controlled separately by switches on the rear instrument panel (refer to Figure 1 below). The total travel of the system is limited to 160 mm (6.3") by a front and a rear stop switch at the slide tube attachment. A full travel from the most rearward to the most forward position takes approximately 10 sec.

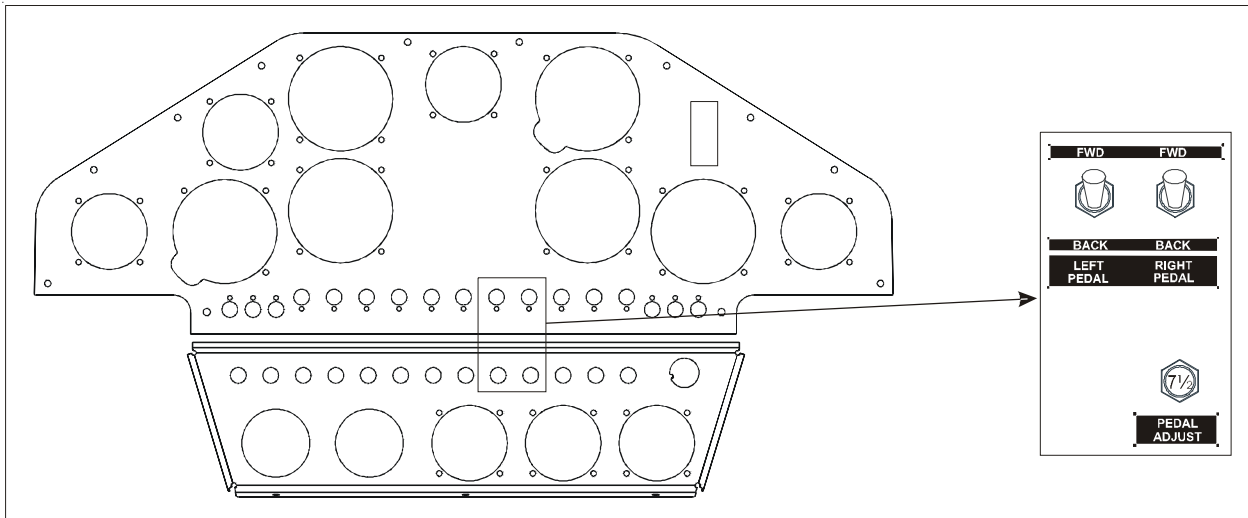

Figure 1, Switch/Circuit Breaker Location

902.8 HANDLING, SERVICING AND MAINTENANCE

Not affected.

**SECTION 903
CABIN HEATING SYSTEM**

Table of Contents

<i>Paragraph</i>		<i>Page</i>
903.1	GENERAL	903-3
903.2	LIMITATIONS	903-3
903.3	EMERGENCY PROCEDURES	903-3
903.4	NORMAL PROCEDURES	903-3
903.5	PERFORMANCE	903-3
903.6	WEIGHT & CENTER OF GRAVITY	903-3
903.7	SYSTEM DESCRIPTION	903-4
903.8	HANDLING, SERVICING AND MAINTENANCE	903-4

Left blank intentionally

903.1 GENERAL

The 330LX can be equipped with a cabin heating system, which allows feeding the front and rear cockpit independently with warm air. The system uses fresh outside air, which is heated up by the engine exhaust muffler. The system is controlled by two handles in the rear cockpit.

903.2 LIMITATIONS

The operation limitations are not affected due to the installation of the cabin heat system.

The following operation placards have to be attached to the aircraft:

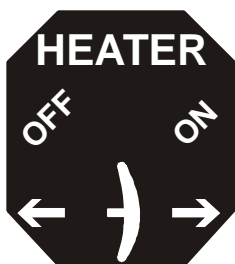

(next to the main handle)

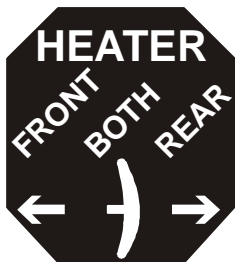

(next to the distribution handle)

903.3 EMERGENCY PROCEDURES

Engine fire:

Heater OFF

903.4 NORMAL PROCEDURES

Not affected.

903.5 PERFORMANCE

Not affected.

903.6 WEIGHT & CENTER OF GRAVITY

Refer to the equipment list in Section 6 of this Handbook.

903.7 SYSTEM DESCRIPTION

On the left front engine baffle a 3" air intake (1, figure 1) with screen is positioned. From there fresh air is routed through a 3" ducting (2) to the exhaust muffler heat shroud (3), where it is heated up. A selector box (4) is placed on the engine side of the firewall. Using the main handle (9) the warm air can there be guided into the cockpit or dumped overboard. A further selector box (5) is located on the aft side of the firewall. Using the distribution handle (8) the ratio of warm air supply between front and rear can be controlled there. The rear selector box incorporates the warm air dispensers for the front occupant as well as the flange for the 2" ducting (6) to the air outlets (7) at the pilot's feet.

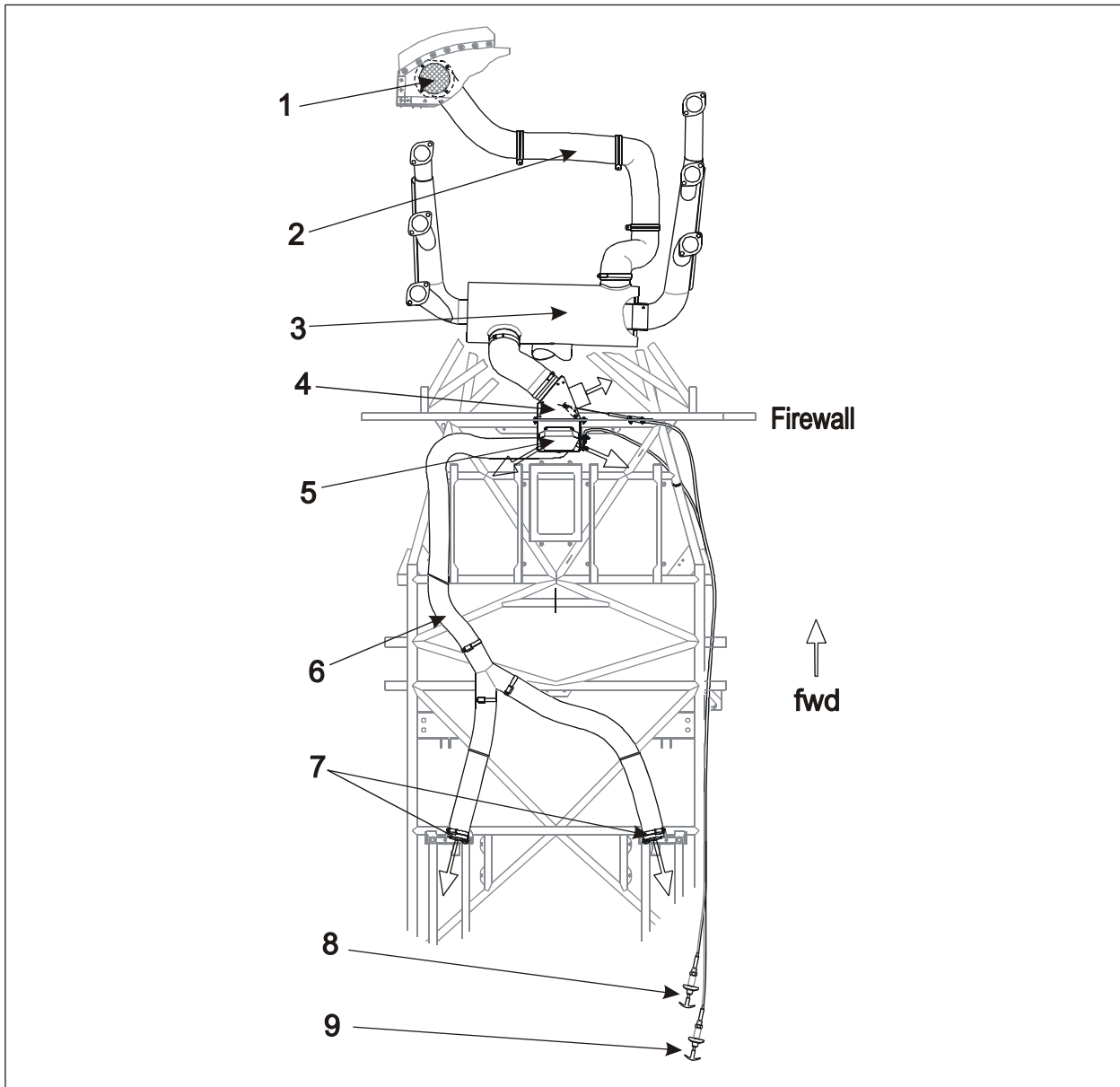

Figure 1

903.8 HANDLING, SERVICING AND MAINTENANCE

Not affected.

SECTION 904
ACCELEROMETER TL-3424_EXT

Table of Contents

<i>Paragraph</i>		<i>Page</i>
904.1	GENERAL	904-3
904.2	LIMITATIONS	904-3
904.3	EMERGENCY PROCEDURES	904-3
904.4	NORMAL PROCEDURES	904-3
904.5	PERFORMANCE	904-3
904.6	WEIGHT AND BALANCE	904-4
904.7	DESCRIPTION	904-4

Left blank intentionally

904 ACCELEROMETER TL-3424_EXT

904.1 GENERAL

The TL-3424_EXT accelerometer can be installed as an option in the EXTRA 330LX. It is used in a special password protected configuration. This configuration helps the pilot to operate the aircraft within limits.

In detail the TL-3424_EXT accelerometer allows:

1. displaying current acceleration values,
2. displaying the minimum and maximum acceleration,
3. recording of all acceleration and speed values into the long-term memory,
4. recording of any exceedance of limits,
5. warning the pilot before reaching load limits by a sound to hear on the head set,
6. indicating to the pilot, when he has exceeded a load or speed limit by a sound on the head set and the G/V LIMITS WARNING LIGHT and
7. transferring recorded data to a computer.

904.2 LIMITATIONS

Markings and Placards:

**G/V LIMITS
WARNING
LIGHT**

next to the red warning light.

904.3 EMERGENCY PROCEDURES

Not affected.

904.4 NORMAL PROCEDURES

Not affected.

904.5 PERFORMANCE

Not affected.

904.6 WEIGHT AND BALANCE

Refer to the Equipment List in Section 6 of this Handbook.

904.7 DESCRIPTION

The complete installation consists of:

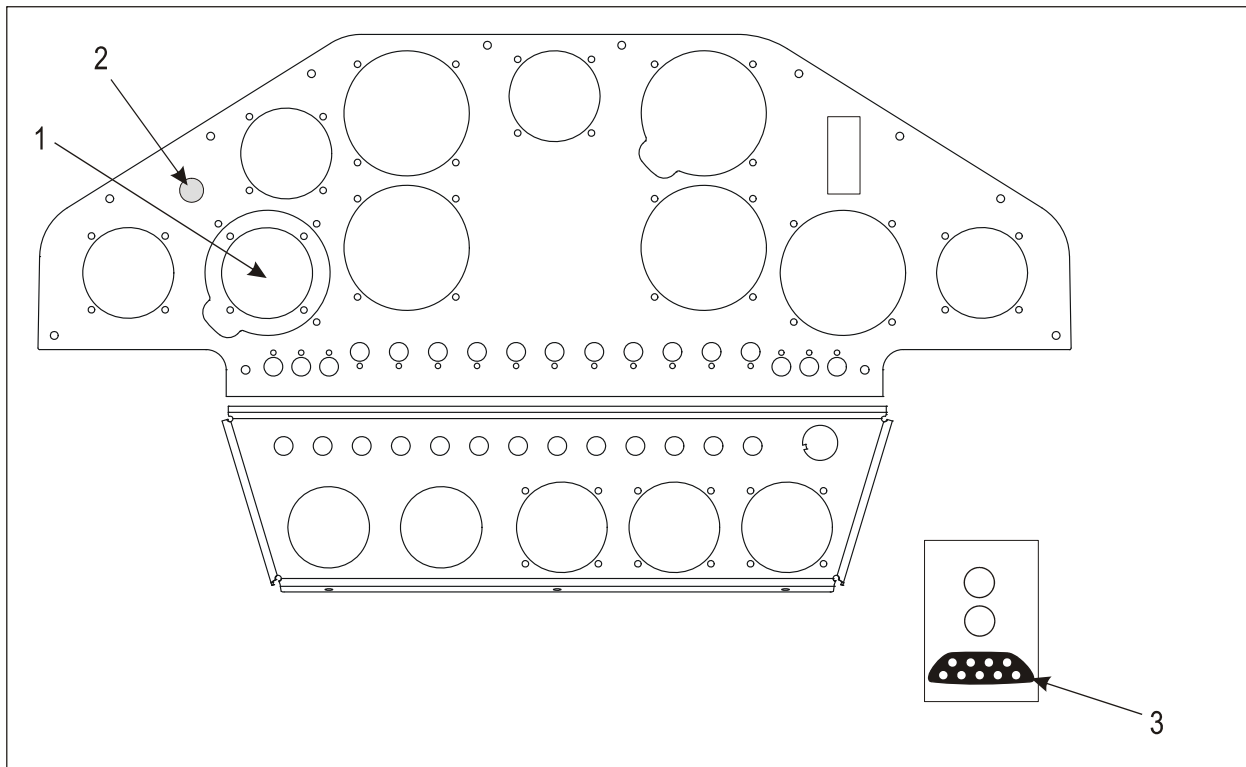

- 1 TL-3424_EXT Accelerometer
- 2 G/V LIMITS WARNING LIGHT
- 3 RS-232c (D-SUB 9 pins [female])

The TL-3424_EXT is complete weight acceleration management. The instrument incorporates a high-precision sensor for measuring acceleration in the vertical axis. The instrument also incorporates a sensor connected to the Pitot/static-system for measuring the indicated airspeed.

It is possible to download the measured values from the instrument via the serial cable RS-232c into a PC.

Pressing the Control and Marker Button enters marks into the memory records and enables the user manual control of the memory recording.

The TL-3424_EXT checks all measured values at two levels - for a warning and an alarm limit signalization. If the measured values are above the warning limit and below the alarm limit an intermitted sound is heard on the head set and the G/V LIMIT WARNING LIGHT flashes. If the measured value exceeds the alarm limit a continuous sound is heard on the head set and the G/V LIMIT WARNING LIGHT illuminates continuously.

When the alarm warning has been activated, the instrument will display a service message after the next turn-on of the instrument to inform the user of the exceeded acceleration.

The USER BUTTON is programmed in the main set-up to display the minimum and maximum acceleration overview.

MEMORY

The following memory types are included in the TL-3424_EXT:

- 1.) A long-term memory storing the last recorded ~30 minutes (20,000 lines, entries every 0.1 seconds).
- 2.) A „Scheck“-Report storing all cases of limit exceedance and the values in the immediate vicinity of this event (160 lines per case).
- 3.) A Line Report storing the last 64 values of limit exceedance (acceleration and speed).

A rolling type memory is used. This means, that in case the available memory capacity is exceeded, the oldest memory lines will be overwritten.

PRESETTINGS

The following values or definitions are preset in the configuration of the TL-3424_EXT:

WARNINGMAX	+9.5 g
WARNINGMIN	-9.5 g
ALARMMAX	+10.1 g
ALARMMIN	-10.1 g
SPEEDLIMIT	220 KIAS
Record begins at	50 KIAS
LANGUAGE	English
SAMPLE RATE	0.1

SYMBOLS

The following symbols are used in the TL-3424_EXT display.

Display Symbol	Meaning
▷	recording to memory
	Recording paused
ACC	Acceleration values indicated
up/down arrows	storing expected, release buttons when setting arrows vanish

CONTROLLING THE INSTRUMENT VIA NAV-MENU

There are black labels on the display. Each is affiliated to the left and the right button. The left label is for the Left button. The right label is for the Right button. Before pressing a button, read the information on the label. Its functions are different in every menu.

To store a value into the memory, press both buttons simultaneously. Release buttons when the setting arrows vanish.

SETTING THE DISPLAY BRIGHTNESS

Press and hold both buttons while switching on the TL 3424 to enter the setup.

Follow the menu navigation.

**SECTION 905
EXTERNAL POWER**

Table of Contents

<i>Paragraph</i>		<i>Page</i>
905.1	GENERAL	905-3
905.2	LIMITATIONS	905-3
905.3	EMERGENCY PROCEDURES	905-3
905.4	NORMAL PROCEDURES	905-3
905.5	PERFORMANCE	905-4
905.6	WEIGHT AND BALANCE	905-4
905.7	DESCRIPTION OF THE SYSTEM	905-4
905.8	HANDLING, SERVICING AND MAINTENANCE	905-4

Left blank intentionally

905 EXTERNAL POWER

905.1 GENERAL

The EXTRA 330LX can be equipped with an external power receptacle system. This system provides the capability to start the engine independent of the board battery and further allows feeding the electrical system for longer periods.

905.2 LIMITATIONS

The operation limitations are not affected due to the installation of the external power receptacle system. For the location of the external power receptacle and protection of the electrical connection cable against overheating the following placard has to be attached on the rear instrument panel with an indicator arrow to the receptacle:

EXTERNAL POWER 12V
DO NOT CRANK FOR MORE THAN 10 SECONDS!
Allow 20 seconds to cool-down between attempts. Repeat up to 6 times.
Then let starter cool for 30 minutes.

905.3 EMERGENCY PROCEDURES

Not affected.

905.4 NORMAL PROCEDURES

The following starting procedures are recommended, however, the starting conditions may necessitate some variation from these procedures.

1. Perform Pre-flight inspection.
2. Set propeller governor control to "High RPM" position.
3. Open throttle approximately 1/4 travel.
4. **Battery switch "OFF"**
5. Alternator switch "OFF"



Risk of damage of electrical system due to reversion of polarity! Check correct polarity before connecting the power plug to the receptacle.

6. Put the external power plug into the board receptacle.
7. Check engine indicating to be operative
8. Turn boost pump "ON".
9. Move mixture control to "FULL RICH" until a slight but steady fuel flow is noted (approximately 3 to 5 seconds) and return mixture control to "IDLE CUT-OFF".
10. Turn boost pump "OFF".



CAUTION

Pay attention to objects and persons in the propeller operating area! Hold the canopy tight!

8. Apply the brakes.
9. Engage starter.
10. When engine fires release the ignition switch back to "BOTH".
11. Move mixture control slowly and smoothly to "FULL RICH".
12. Check the oil pressure gauge. If minimum oil pressure is not indicated within 30 seconds, shut off the engine and determine trouble.
- 13. Battery switch "ON".**
14. Pull the external power plug from the board receptacle.

905.5 PERFORMANCE

Not affected.

905.6 WEIGHT AND BALANCE

Refer to the Equipment List in Section 6 of this Handbook.

905.7 DESCRIPTION OF THE SYSTEM

The external power receptacle with its spring-loaded door is attached left under the seat and reachable from outside. It is directly connected to the aircraft electrical system and does not feature an inverse-polarity protection (refer to Fig. 7-4). So it is advisable to check correct polarity of the external power plug.

During the engine start, the battery switch has to be switched in "**OFF**"-position for the disconnection of the battery from the aircraft electric circuit.

905.8 HANDLING, SERVICING AND MAINTENANCE

Not affected.

SECTION 906
DIGITAL RPM INDICATOR

Table of Contents

<i>Paragraph</i>		<i>Page</i>
906.1	GENERAL	906-3
906.2	LIMITATIONS	906-3
906.3	EMERGENCY PROCEDURES	906-3
906.4	NORMAL PROCEDURES	906-3
906.5	PERFORMANCE	906-3
906.6	WEIGHT AND BALANCE	906-4
906.7	DESCRIPTION AND OPERATION OF THE SYSTEM	906-4
906.8	HANDLING, SERVICING AND MAINTENANCE	906-6

Left blank intentionally

906 DIGITAL RPM INDICATOR

906.1 GENERAL

The EXTRA 330LX is as standard equipped with an "P-1000" Digital rpm indicator. Depending on the category in which the aircraft is operated, one of the following models is used:
P100-230-635-00 (max. 2600 rpm)
P100-230-643-00 (max. 2700 rpm, for aerial work)

906.2 LIMITATIONS

The operation limitations are not affected by the installation of the "P-1000" Digital RPM indicator.
The model of digital RPM indicator installed must match the applicable RPM limitation approved for the propeller installed. Refer to the applicable noise level limitation included in section 4 or within any relevant supplement.
The face of the indicator is placarded with the unchanged engine RPM operating range. Additionally the operating RPM ranges are indicated by a large green, yellow, and a red LED. These LEDs are located on the upper right corner of the indicator face.

Model P100-230-635-00 (max. 2600RPM):

Green	2400 ----- 700	Yellow	2600 ----- 2400	Red	3500 ----- 2600
-------	----------------------	--------	-----------------------	-----	-----------------------

Model P100-230-643-00 (max. 2700RPM):

Green	2400 ----- 700	Yellow	2700 ----- 2400	Red	3500 ----- 2700
-------	----------------------	--------	-----------------------	-----	-----------------------

906.3 EMERGENCY PROCEDURES

Not affected.

906.4 NORMAL PROCEDURES

Not affected

906.5 PERFORMANCE

Not affected.

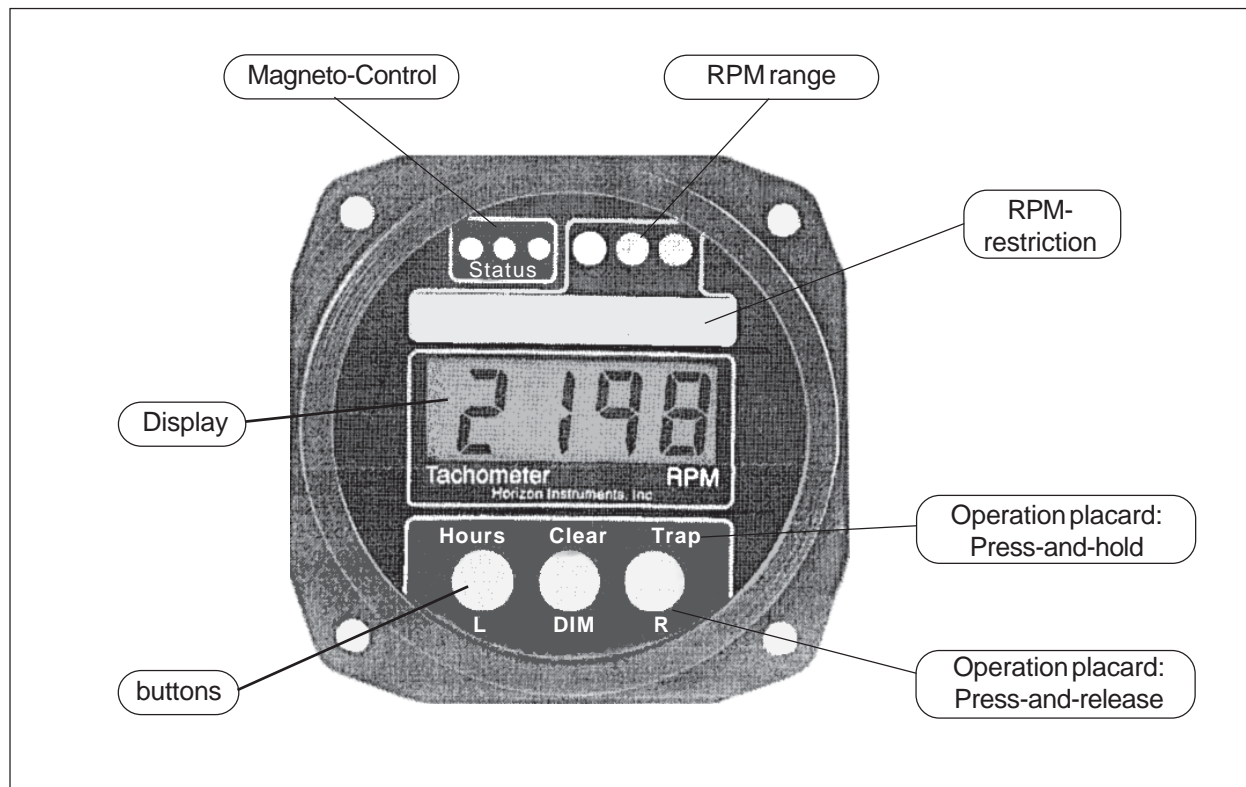

906.6 WEIGHT AND BALANCE

Refer to the Equipment List in Section 6 of this Handbook.

906.7 DESCRIPTION AND OPERATION OF THE SYSTEM

The operation of the indicator is straight-forward. After power is supplied to the indicator, the engine is started, and the self tests are performed, the default display of the engine rpm appears on the display. The default display is insured via the use of internal timers that will restore the display to the current rpm even in the event that one of the panel buttons becomes stuck or defective.

Internally, two independent tachometers watch the pulses received from each magneto. Each tachometer is accurate to less than 1 rpm and can be individually enabled/disabled via buttons on the face of the indicator.

Ignition Switch Position	Tachometer Magneto Alert Indicator Lights	
	LEFT Status LED	RIGHT Status LED
OFF	ON	ON
RIGHT	ON	OFF
LEFT	OFF	ON
BOTH	OFF	OFF

RPM RANGES

The face of the indicator is placarded with the respective engine rpm operating range. Additionally the engine operating ranges are indicated by the large green, yellow, and red LEDs. These LEDs are located on the upper right corner of the indicator face.

Green $\frac{2400}{700}$ Yellow $\frac{2600/2700}{2400}$ Red $\frac{3500}{2600/2700}$

MAGNETO-CHECK

Three small LED magneto system alert indicator lights are located within the "Status" area on the upper left corner of the indicator face.

The left and right red LED alert indicator lights, when illuminated, indicate, because of loss of ignition signal to the tachometer, a possible malfunction of the respective left or right magneto ignition system.

While performing a magneto check during engine run-up, the red alert indicator lights will illuminate, thus identifying the grounding of the respective right or left magneto systems.

Between the left and right magneto ignition system alert indicators is a yellow **rpm Synchronization indicator**. This small yellow indicator is illuminated when there is a difference of more than 50 rpm between the right and left tachometers.

This indicator also may flicker during extreme rpm excursions of the engine.

OPERATION BUTTONS

There are three panel buttons. Each button has two modes of operation.

PRESS-AND-HOLD operation mode

(press and hold for more than 2/3 of a second)

This operation mode is placarded above each button. (*Hours, Clear, Trap*)

Engine time (*Hours*)

The left button, upon depression, will cause the tachometer to display the non-fractional portion (0000.) of the current accumulated engine hours. When the button is released, the fractional part of the engine hours (.00) is displayed for a short period of time. The clock is started whenever the engine rpm exceeds 800 rpm and is recorded in real hours.

Clear (Clear)

The middle button clears the rpm trap. During depression of the switch, the rpm trap is zeroed. When the button is released, the trap will record the current engine rpm.

Engine rpm (Trap)

The right button will cause the tachometer to display the current contents of the rpm trap. This trap records the **highest engine rpm** achieved before the button was pressed.

PRESS-AND-RELEASE operation mode

(press and release in less than 2/3 of a second)

This operation mode is placarded below each button. (*L*, *DIM*, *R*)

Masks (*L*, *R*)

During normal operation, the tachometer presents the average of the left and right internal tachometers on the display. However, a mechanism **exists to mask** either tachometer from the display, leaving the remaining tachometer to determine magneto/ignition problems.

Quickly pressing and releasing the left button (*L*), causes the tachometer to mask the left tachometer.

Quickly pressing and releasing the right button (*R*), causes the tachometer to mask the right tachometer.

Dimmer (*DIM*)

Quickly pressing and releasing the middle button (*DIM*), causes the tachometer to alternately dim or brighten the LED indicators (except the large red LED of the rpm Range).

906.8 HANDLING, SERVICING AND MAINTENANCE

Not affected.

**SECTION 907
SMOKE SYSTEM**

Table of Contents

<i>Paragraph</i>		<i>Page</i>
907.1	GENERAL	907-3
907.2	LIMITATIONS	907-3
907.3	EMERGENCY PROCEDURES	907-3
907.4	NORMAL PROCEDURES	907-4
907.5	PERFORMANCE	907-5
907.6	WEIGHT AND BALANCE	907-5
907.7	DESCRIPTION OF THE SYSTEM	907-5
907.8	HANDLING, SERVICING AND MAINTENANCE	907-7

Left blank intentionally

907 SMOKE SYSTEM

907.1 GENERAL

For performing at airshows, the EXTRA 330LX may optionally be equipped with a smoke system.

907.2 LIMITATIONS

For safe operation of the smoke system the following limitations have to be considered:

- 1) The **load factor** and "**MTOW**" are limited to:
+8g/-8g at 870kg (ACRO II, limited to single seat operation), and
+6g/-6g at 950kg (ACRO III)
- 2) **Specification** of the smoke oil: straight paraffin oil, viscosity 30-50 cSt at 20°C (68°F), initial boiling point >330°C (626°F)
For example: *Fauth FC05, Texaco Canopus 13* or equivalent
- 3) Local **airfield** and **weather conditions** have to be considered:
For the prevention of a fire alarm, inform the flight control before you activate the smoke system
- 4) Recommended **Manifold pressure**: min. 20" Hg
- 5) The activation of the smoke system **on ground is only allowable for a brief system test.**
- 6) Wearing a parachute is strongly recommended.

Operating Markings & Placards:

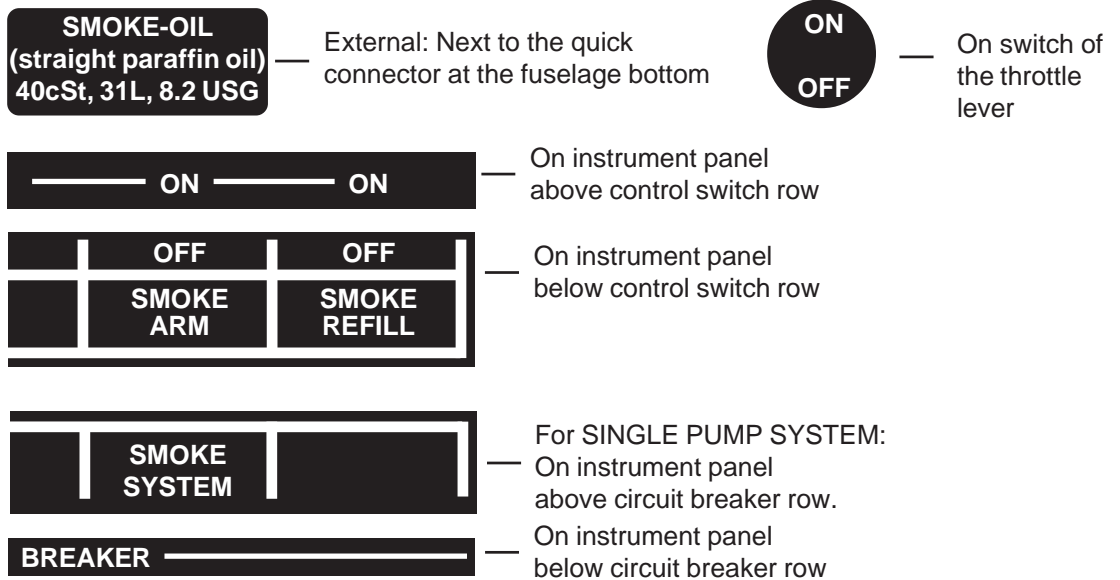

907.3 EMERGENCY PROCEDURES

FAILURE OF THE SMOKE-SYSTEM

1. Switch "SMOKE ARM" and "SMOKE REFILL": OFF
2. Circuit breaker PULL

FIRE IN FLIGHT

- | | |
|-----------------------|-----|
| 1. Switch "SMOKE ARM" | OFF |
|-----------------------|-----|



If the fire (after the smoke system is shut off) will not extinguish proceed as follows:

- | | |
|--|---|
| 2. Mixture | IDLE CUT OFF |
| 3. Fuel selector valve | OFF (Pull & Turn) |
| 4. Battery switch | OFF |
| 5. Airspeed | 100 KIAS (185 km/h)
find your airspeed/attitude that
will keep the fire away from the cockpit |
| 6. Land | <i>AS SOON AS POSSIBLE</i> |
| 7. If fire persists or aircraft is uncontrollable
and wearing a parachute | BAIL OUT |

SMOKE IN THE COCKPIT

- | | |
|---|-----------------------------|
| 1. Switch "SMOKE ARM" | OFF |
| 2. Bad weather window | OPEN |
| 3. Ventilation | OPEN |
| 4. If smoke persists in the cockpit, land | <i>AS SOON AS PRACTICAL</i> |

907.4 NORMAL PROCEDURES

The smoke system includes features for refilling the smoke tanks and smoke generation:

A) REFILL

A separate refill hose is delivered with the smoke system which has to be used for filling the smoke oil tanks from the paraffin oil supply canister or barrel.

- | | |
|--------------------------|--|
| 1. Refill hose | CONNECT hose nipple to quick
connector at the fuselage bottom;
IMMERSE the other end into the paraffin
oil in the canister/barrel |
| 2. Switch "SMOKE REFILL" | ON |

NOTE

The refilling should start within max. 30 sec. If this is not the case, the refill lines, fittings and filter (if installed) have to be checked for soiling or leaks. Refilling procedure can be supported by reducing the suction height e.g. lifting the canister. The fully filled status is sensed by the floating device which automatically switches the refilling off.

After automatic refill shut-off :

- | | |
|--------------------------|------------|
| 3. Switch "SMOKE REFILL" | OFF |
| 4. Refill hose | DISCONNECT |



CAUTION

A shut-off failure of the refill process can be recognized by smoke oil spilling out of the vent line. In this case, turn off refill switch. The floating device switch in the main smoke oil tank has to be checked accordingly.

B) SMOKE GENERATION

- | | |
|---|----------------|
| 1. Bad weather window and ventilation | CLOSE |
| 2. "SMOKE ARM" Switch | ON |
| 3. Manifold Pressure | minimum 20" Hg |
| 4. Switch in the throttle lever
for smoke generation | ON - OFF |

NOTE

It is recommended to operate the smoke system only in forward flight, because during reverse maneuvers (for example tail slide) smoke might enter the cockpit via the air vents.

907.5 PERFORMANCE

Not affected.

907.6 WEIGHT AND BALANCE

Capacity		Mass		Moment	
Litre	US gal	Kg	lbs	Kgcm	in-lbs
5	1.3	4.3	9.4	119	103
10	2.7	8.5	18.7	214	186
15	4	12.8	28.1	367	319
20	5.3	17	37.5	495	430
25	6.6	21.3	46.9	622	541
31	8.2	26.4	58.2	775	674

Specific Weight of the paraffin oil = 0.85 kg/Litre

NOTE

The smoke system does not feature a capacity dipstick. In the case of unknown filling, the smoke oil tanks should be drained and refilled with a known quantity. If this is not possible, the most adverse case has to be taken for CG calculation. (This may be either completely full or completely empty tanks).

907.7 DESCRIPTION OF THE SYSTEM

On pilot's demand the smoke system produces a trail of smoke by injection of smoke oil (straight paraffin oil) into the engine exhaust. The smoke oil is vaporised by the exhaust gas heat and is visible as dense smoke after leaving the exhaust.

For smoke system activation the "SMOKE ARM" switch located on the pilot instrument panel needs to be switched ON first. The smoke „ON-OFF“ toggle switch is located on top of the

throttle lever. For filling the smoke oil tanks the "SMOKE REFILL" switch needs to be ON. After the refill process is completed the "SMOKE REFILL" has to be switched OFF. When both switches ("SMOKE ARM" and "SMOKE REFILL") are in the ON position, the smoke system is not energized and will not run.

A pump (reversed polarity) fills the floptube smoke oil tank through a quick connector located in the aircraft belly fairing. This line includes a filter to prevent dirt to enter the smoke system. The separate main smoke oil tank is finally filled through the interconnected floptube smoke oil tank. Filled tanks are detected by a float switch placed in the main smoke oil tank which shuts the pump off. The same pump (normal polarity) injects the smoke oil from the floptube smoke oil tank through an overpressure/check valve and the injector nozzle into the hot exhaust gas to generate smoke.

The system consists of:

- Main smoke oil tank with float switch
- Floptube smoke oil tank
- Refill/Injection pump in the pilot compartment with quick connector in the belly fairing
- Overpressure/check valve in the smoke oil supply line to the nozzle
- Filter element in the refill line
- ON-OFF switch on the throttle lever
- Two relays (changeover contact type) for pump control
- "SMOKE ARM" switch to arm the system and "SMOKE REFILL" switch for refilling placed at the instrument-panel
- Only 1 circuit breaker for pump and control placed at the instrument-panel

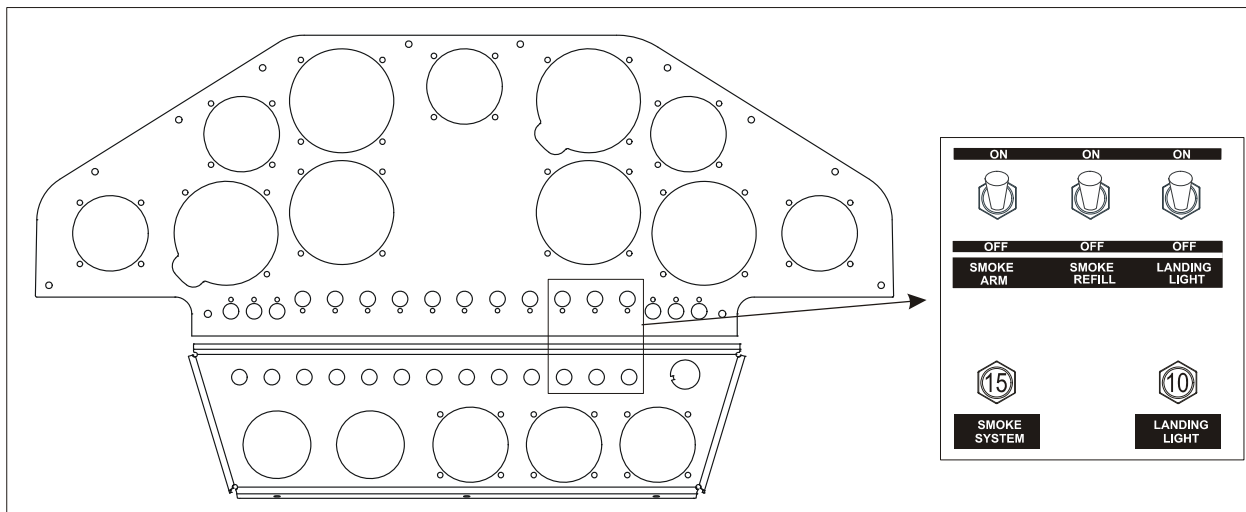

907.8 HANDLING, SERVICING AND MAINTENANCE

At every refilling:

- Check automatic shut-off

Additionally during the 100h Check

- Check the system for leakage (lines, fittings, tanks)
- Check the smoke oil tanks for proper attachment
- Clean the overpressure/check valve: if required, remove oil residue
- Clean the injector nozzle: if required, remove carbon debris
- Clean the filter element

After each flight with activated Smoke System

- Clean the aircraft belly fairing and the rudder cables from smoke oil contamination

NOTE

The rudder cables might suffer from increased wear, when they are covered with smoke oil and dust.

Left blank intentionally

**SECTION 908
SINGLE SEAT CANOPY**

Table of Contents

<i>Paragraph</i>		<i>Page</i>
908.1	GENERAL	908-3
908.2	LIMITATIONS	908-3
908.3	EMERGENCY PROCEDURES	908-3
908.4	NORMAL PROCEDURES	908-3
908.5	PERFORMANCE	908-3
908.6	WEIGHT AND BALANCE AND EQUIPMENT LIST	908-3
908.7	DESCRIPTION OF THE SYSTEM	908-3
908.8	HANDLING, SERVICE AND MAINTENANCE	908-3

Left blank intentionally

908 SINGLE SEAT CANOPY

908.1 GENERAL

For airshow performances the standard canopy can be replaced by a single seat canopy, which gives a gorgeous appearance.

908.2 LIMITATIONS

With the single seat canopy installed the aircraft is limited to the categories
NORMAL and ACRO I.

In the NORMAL category the aircraft can be flown only with the pilot in the rear seat.

908.3 EMERGENCY PROCEDURES

Not affected.

908.4 NORMAL PROCEDURES

Before starting engine, check front seat area and ensure seat belts and shoulder harness of front seat are completely removed or fastened and secured, so that nothing can obstruct the free movement of controls.

908.5 PERFORMANCE

Not affected.

908.6 WEIGHT AND BALANCE AND EQUIPMENT LIST

Refer to the equipment list in section 6.

908.7 DESCRIPTION OF THE SYSTEM

The single seat canopy has been designed to easily replace the standard canopy. This can be achieved by using the same canopy frame, hinges and latches included. The front seat is covered by the flat portion of the frame in front of the canopy. Operation of the locking mechanism is feasible only from the rear seat.

908.8 HANDLING, SERVICE AND MAINTENANCE

Not affected.

Left blank intentionally

SECTION 909
ARTEX ME-406 ELT

Table of Contents

<i>Paragraph</i>		<i>Page</i>
909.1	GENERAL	909-3
909.2	LIMITATIONS	909-3
909.3	EMERGENCY PROCEDURES	909-4
909.4	NORMAL PROCEDURES	909-4
909.5	PERFORMANCE	909-4
909.6	WEIGHT & CENTER OF GRAVITY	909-4
909.7	SYSTEM DESCRIPTION	909-5
909.7.1	Switch Operation	909-5
909.7.2	Self Test Mode	909-5
909.8	HANDLING, SERVICING AND MAINTENANCE	909-6
909.8.1	Transmitter Test	909-6
909.8.2	Self Test	909-6

Left blank intentionally

909.1 GENERAL

To improve the passive security, the EXTRA 330LX can be equipped with an optional Emergency Locator Transmitter ARTEX ME-406.

In the event of a crash, the ME-406 activates automatically (automatic fixed „AF“ configuration), and transmits the standard swept tone on 121.5 MHz lasting until battery power is gone. This 121.5 MHz signal is mainly used to pinpoint the beacon during search and rescue operations. In addition, for the first 24 hours of operation, a 406 MHz signal is transmitted at 50-second intervals. This transmission lasts 440 ms and contains identification data programmed into the beacon and is received by Cospas-Sarsat satellites. The transmitted data is referenced in a database (maintained by the national authority responsible for ELT registration) and used to identify the beacon and owner.

When the ELT is activated, the buzzer 'beeps' and the panel LED pulses periodically. The time between pulses lengthen after a predetermined transmitter 'on' time.

NOTE

In October 2000 the International Cospas-Sarsat Program, announced at its 25th Council Session held in London, UK that it plans to terminate satellite processing of distress signals from 121.5 and 243 MHz emergency beacons on February 1, 2009.

Accuracy

Doppler positioning is employed using both 121.5 MHz and 406 MHz signals. Position accuracy of the 121.5 MHz signal is within an area of approximately 15-20 km radius about the transmitter. Due to the better signal integrity of the 406 MHz, its location accuracy is within about a 3 km radius.

909.2 LIMITATIONS

The operation limitations are not effected due to the installation of the ARTEX ME-406 ELT.

For the location and operation of the transmitter the following placards have to be attached to the aircraft:

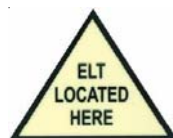

(outside on the left fuselage in the vicinity of the ELT unit)

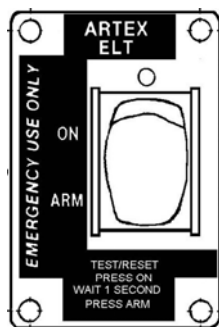

(next to the ELT remote switch)

**FOR AVIATION EMERGENCY USE ONLY
UNAUTHORIZED OPERATION PROHIBITED**

(as close to the ELT remote switch as practical)

909.3 EMERGENCY PROCEDURES

- In case of a forced landing turn the remote switch in the rear panel to the "ON" position prior to touch down.

Although the ELT will be activated automatically after an aircraft accident or forced landing with high G-force,

- turn additionally the remote switch in the rear panel to the "ON" position.

After sighting rescue aircraft:

- Switch the remote switch to the "ARM" position to prevent radio interference.
- Attempt contact with rescue aircraft with the radio transceiver set to a frequency of 121.5 MHz. If no contact is established, switch the remote switch to the "ON" position immediately.

If the function of the remote switch is in doubt proceed as follows:

- Remove quick pins from the backrest adjustment and swivel the backrest forward to get access to the ELT unit.
- Use the unit master switch at the ELT unit analogously.

FUNCTION CHECK OF THE ELT

If the aircraft receiver is operable listen on 121.5 MHz for ELT transmission. Ensure that the antenna is clear of obstruction.

909.4 NORMAL PROCEDURES

Not affected.

909.5 PERFORMANCE

Not affected.

909.6 WEIGHT & CENTER OF GRAVITY

Refer to the equipment list in Section 6 of this Handbook.

909.7 SYSTEM DESCRIPTION

The ELT installation consists of the ELT unit and a buzzer, both fastened to the fuselage structure aft of the back seat, an antenna located on the main fuselage cover behind the cockpit, and a remote switch with LED indication located on the instrument panel. The switch has the positions ARM and ON.

909.7.1 SWITCH OPERATION

In a crash, an acceleration activated crash sensor (G-switch) turns the ELT 'on' automatically when the ELT experiences a change in velocity (or deceleration) of 4.5 fps \pm 0.5 fps. Activation is also accomplished by means of the cockpit mounted remote switch or the switch on the ELT. To deactivate the ELT set either switch to the 'ON' position, then back to 'ARM'.

The ELT does not have an 'OFF' position. Instead, a jumper between two pins on the front D-sub connector must be in place for the G-switch to activate the unit. The jumper is installed on the mating half of the connector so that when the connector is installed, the beacon is armed. This allows the beacon to be handled or shipped without 'nuisance' activation (front connector removed).

NOTE

The ELT can still be manually activated using the local switch on the front of the ELT. Care should be taken when transporting or shipping the ELT not to move the switch or allow packing material to become lodged such as to toggle the switch.

909.7.2 SELF TEST MODE

Upon turn-off (from „ON“ back to „ARM“ state), the ELT automatically enters a self-test mode that transmits a 406 MHz test coded transmission that monitors certain system functions before returning to the 'ARM' mode. The transmission is ignored by any satellite that receives this signal, but the ELT requires it to check output power and correct frequency. If the ELT is left activated for approximately 50 seconds or more, a distress signal is generated that is accepted by the satellites.

In addition to 121.5 and 406 MHz signal integrity, other operating parameters are checked during the self-test. Error codes are then generated if other problems are found. The error codes are displayed by a series of „blinks“ of the ELT LED, remote LED and audio indicator. See „Installed Transmitter Test“ section for more details and a description of the error codes.

NOTE

Any time the ELT is activated, it is transmitting a 121.5 MHz distress signal. Therefore, all activations of the ELT should be kept to a minimum. Local or national regulations may limit testing of the ELT or impose special requirements or conditions to perform testing. For the „self test“, Artex recommends that the ELT be „ON“ for no more than 5 seconds. Testing should occur during the first 5 minutes after the hour.

909.8 HANDLING, SERVICING AND MAINTENANCE

909.8.1 TRANSMITTER TEST

ARTEX recommends that the ELT be tested every 1-2 months. Follow the steps outlined in the 909.8.2 SELF TEST paragraph.

NOTE

The self-test time is accumulated in a register on the battery pack. The register records activation time in 30 second increments so all activations will count as at least 30 seconds, even if the actual time is much less. Total allowable time is 60 minutes as determined by FAR 91.207 and RTCA DO-204. After this time has been accumulated a 7-flash error will be presented after the self-test. The battery must be replaced at this point for the ELT to remain in compliance. Always follow ELT testing requirements per local or national authorities.

Always perform the tests within the first 5 minutes of the hour. Notify any nearby control tower of your intentions, in accordance with AC 43.13. If outside of the US, always follow all local or national regulations for testing of ELT's.



Do not allow test duration to exceed 5 seconds. A false alarm may be generated.

Any time the ELT is activated, it is transmitting a 121.5 MHz distress signal. After approximately 50 seconds, a „live“ 406 MHz distress signal is transmitted and is considered valid by the satellite system.

Whenever the ELT is switched from „ON“ to „ARM“ a 406 MHz signal is transmitted, however, it is specially coded as a „self test“ signal that is ignored by the COSPAS-SARSAT satellites.

909.8.2 SELF TEST

- Tune a receiver (usually the aircraft radio) to 121.5 MHz. Turn the ELT aircraft panel switch „ON“ for about 1 second, then back to the „ARM“ position. The receiver should voice about 3 audio sweeps.

- At turn-off (back to 'ARM' state) the panel LED should present 1 pulse (buzzer will not sound for 1 pulse). If more are displayed, determine the problem from the list below.

1 Flash Indicates that the system is operational and that no error conditions were found.

3 Flashes Bad load detected. Detects open or short condition on the antenna output or cable. These problems can probably be fixed by the installer.

- Check that the RF cable is connected and in good condition. Perform continuity check of center conductor and shield. Check for a shorted cable.

- Check for intermittent connection in the RF cable.

- If this error code persists there may be a problem with the antenna installation. This can be checked with a VSWR meter. Check the antenna for opens, shorts, resistive ground plane connection.

4 Flashes Low power detected. Occurs if output power is below about 33 dBm (2 watts) for the 406 signal or 17 dBm (50 mW) for the 121.5 MHz output. Also may indicate that 406 signal is off frequency. For this error code the ELT must be sent back for repair or replacement.

5 Flashes Indicates that ELT has not been programmed, or is incorrectly programmed. Does not indicate erroneous or corrupted programmed data.

6 Flashes Indicates that the G-switch loop between pins 5 and 12 at the D-sub connector is not installed. ELT will not activate during a crash.

- Check that the harness D-sub jumper is installed by verifying less than 1 ohm of resistance between pins 5 and 12.

7 Flashes Indicates that the ELT battery has too much accumulated operation time (> 1hr, see below). Battery may still power ELT; however, it must be replaced to meet FAA specifications. May also indicate damage to the battery circuit.

Left blank intentionally

SECTION 910
NAT AA83-001 INTERCOM

Table of Contents

<i>Paragraph</i>		<i>Page</i>
910.1	GENERAL	910-3
910.1.1	Installation Adjustments	910-3
910.2	LIMITATIONS	910-3
910.3	EMERGENCY PROCEDURES	910-4
910.4	NORMAL PROCEDURES	910-4
910.5	PERFORMANCE	910-4
910.6	WEIGHT AND BALANCE	910-4
910.7	SYSTEM DESCRIPTION	910-4
910.7.1	Controls and Indicators	910-4
910.7.2	Operation	910-6
910.7.3	Functions	910-7

Left blank intentionally

910.1 GENERAL

The AA83-001 is a stereo voice-activated intercom, providing full intercom capabilities for pilot and copilot. Further passenger features are not used in the configuration installed. The AA83-001 also provides transmit capability for pilot and co-pilot to a single COM radio or audio selector panel. The AA83-001 accepts stereo music inputs from either portable or fixed entertainment systems to produce high quality stereo headset output.

The stereo music audio is muted during transmit or intercom operation and when receive audio is detected, permitting greater intelligibility of incoming transmissions. The AA83-001 muting depth adjustment ranges from complete music muting to gentle background music on command, with a fast attack and slow level return for optimum user comfort.

Each microphone is individually gated, for the best possible noise performance during VOX operation. A panel annunciator allows easy visual setting of the VOX threshold, and also indicates transmit operation. The AA83-001 provides full boom-mic transmit and ICS functions for the pilot and copilot. Pilot priority on transmit and pilot isolation/fail-safe (direct connection to the aircraft radio system) are standard features.



CAUTION

Ensure headsets are of good quality and are installed correctly. NEVER USE MONO AIRCRAFT HEADSETS in this system unless the installation has been specifically wired for mono operation, as they will short cut one side of the AA83-001 power amplifier when installed in stereo jacks. This may result in eventual unit failure, which IS NOT COVERED BY WARRANTY. Use only stereo headsets with this system.

910.1.1 INSTALLATION ADJUSTMENTS

Using individual level trimpots an approved dealer can adjust the following audio levels during service, or at the time of installation.

- Music mute level
- Music Bass level
- Music balance
- RX Balance
- RX volume level
- ICS Balance
- ICS Bass level

910.2 LIMITATIONS



(Next to the front audio sockets)



(Next to the rear audio sockets)

910.3 EMERGENCY PROCEDURES

Not applicable

910.4 NORMAL PROCEDURES

Not applicable

910.5 PERFORMANCE

Not applicable

910.6 WEIGHT AND BALANCE

Refer to the Equipment List in Section 6 of this Handbook.

910.7 SYSTEM DESCRIPTION

910.7.1 CONTROLS AND INDICATORS

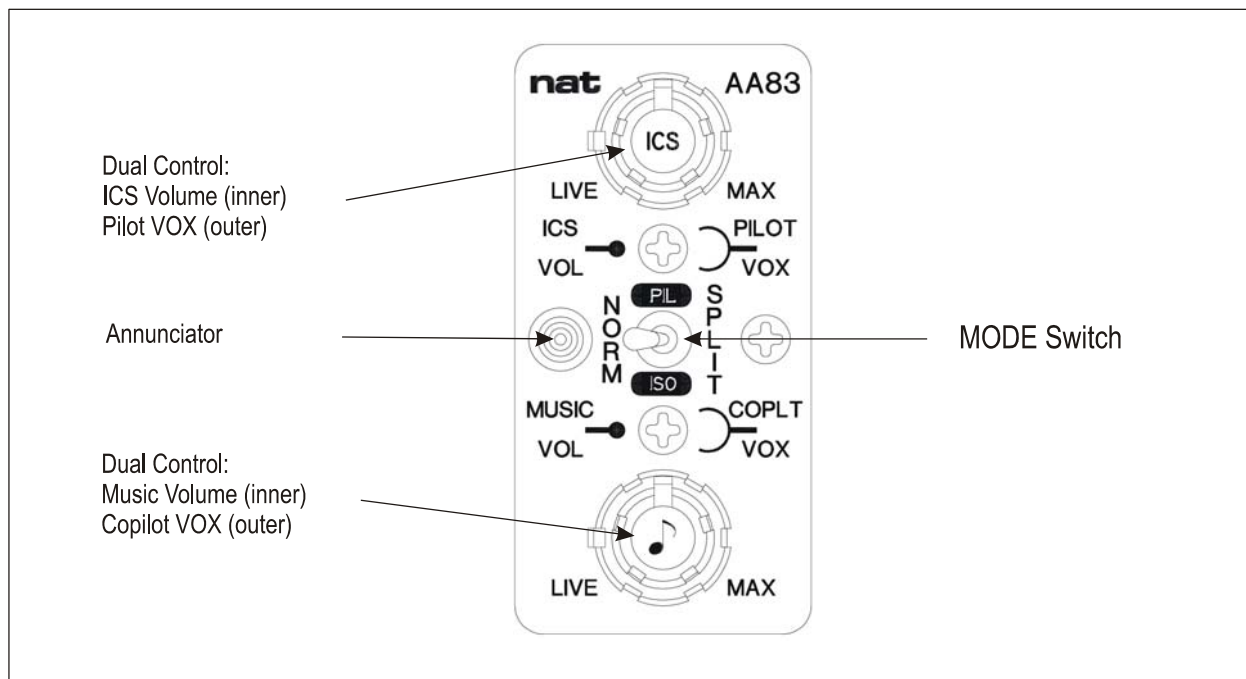

ICS VOL/PILOT VOX

This control is a fluted concentric rubber knob on the top of the panel.

The inner (front) knob is the ICS VOL control, which is used to set intercom volume. It is at minimum volume when fully counterclockwise (ccw). As the knob is rotated clockwise (cw), the ICS volume for the crew increases. The ICS is muted during transmit operations.

The outer (rear) knob is the PILOT VOX control, that controls VOX for the pilot only. For full information on VOX operation, see section 910.7.2 below.

MUSIC VOL/COPILOT VOX

This control is a fluted concentric rubber knob on the bottom of the panel.

The inner (front) knob is the MUSIC VOL control, which is used to set normal music volume. The volume can be adjusted from minimum (fully ccw) to maximum (fully cw).

The outer (rear) knob is the COPILOT VOX control, that controls VOX for the copilot and passengers. For full information on VOX operation, see section 910.7.2 below.

ANNUNCIATOR

The panel annunciator is a bi-colour LED that shows intercom status.

If the LED is illuminated green, it indicates transmit activity, and if it is red, it indicates VOX activity. For transmit with sidetone or mic activity, it will illuminate amber. The green LED also indicates a possible stuck mic if still lit after transmission is concluded.

MODE CONTROL

The mode control is a three-position toggle switch used to select the operational mode of the unit. The selectable positions are SPLIT, PIL ISO and NORMAL. These modes are described fully in section 910.7.2 below.

PTT SWITCHES

PTT Switches are installed on the control sticks. They are used for radio transmissions. Further PTT switches are installed on the power levers and are used for the intercom.

SOCKETS

Dual sockets for connecting the headsets are installed on the right side of each seat. The aft cockpit also features a receptacle for music input.

910.7.2 OPERATION

VOX OPERATION

The VOX control is used to set the level of audio required to activate the microphones.

The AA83-001 provides three modes of intercom operation, selected by the position of the VOX control.

LIVE ICS When the VOX control is positioned fully ccw to the LIVE position, all mics will be live, and any sound picked up will be processed by the ICS system (hot mic).

KEYED ICS When the VOX control is positioned fully cw to the MAX position, the intercom will be in a keyed-only mode.

VOX ICS When the VOX control is positioned between fully cw and fully ccw, the intercom is in VOX mode. To establish the VOX threshold, rotate the control ccw until the LED turns red, and then rotate the control cw until the LED goes dark. Continue turning the control cw until the desired voice sensitivity is set.

NORMAL OPERATION

In normal use, the AA83-001 serves as a common intercommunication system, and a flow-through interface for connection to the ship's external communication system. The NORM mode (default) permits everyone on the system to talk to each other, listen to music, and hear all radio communications.

Radio transmit functions may be initiated by either the pilot or the copilot. The pilot has priority.

In NORM mode, external tie line users are included in the ICS communications.

PIL ISO (PILOT ISOLATION) OPERATION

In normal operation, the pilot and copilot hear the same signals from the aircraft communication system. Sometimes this is not desirable from the pilot's perspective, for instance during communication with the tower on approach, or when discussions on the intercom would be a distraction. Many times the copilot position is simply another passenger, and the pilot may wish to be isolated from him.

PILOT ISO mode separates the radio communications without pilot from the intercom network, allowing confidential interference from the copilot intercom or music. The pilot has no ICS operation, and all signals are presented in mono format during this mode. The other user is unaffected and continues to use the entertainment functions of the AA83-001.

While in PILOT ISO mode, the pilot maintains complete control of all the radio functions of the intercom, and the pilot mic and TX keyline are directly connected to the transceiver. The pilot phones are driven by the transceiver.

The copilot will be unable to monitor any transceiver activity, although he retains full ICS and music functions.

This mode is 'fail-passive' meaning that it requires no power to operate and is the same mode the box goes into automatically when power is lost to the AA83-001. In this way, switch over is immediate for the pilot and there is no possibility of lost communication because of a lack of pilot action. Note that the pilot's boom mic is sent directly to the radio in this mode, and only a PTT key input is needed to transmit.

NOTE

In this mode, the receive/sidetone levels may require adjustment at the audio source.

SPLIT OPERATION

Operation in SPLIT Mode is similar to NORM mode, but if the AA83-001 is connected as part of a multi-unit system, the SPLIT mode allows external users to be disconnected from the AA83-001 ICS communications without requiring adjustment of the ICS Audio level.

All users are permitted to talk to each other, listen to music, and hear all radio communications.

There is provision for an external ICS tie line load to maintain the ICS audio at the same level as in NORM mode.

910.7.3 FUNCTIONS

RADIO FUNCTIONS

There are two PTT inputs: one each for the pilot and copilot on the control stick. Activation of either PTT input connects the user's MIC to the radio, and activates the output PTT to the radio.

Sidetone audio input is provided from the radio, not by the AA83-001 microphone circuits. Transmit sideline audio utilizes AA83-001 Radio RX audio and phones driver circuits.

Radio RX/sidetone is a mono signal, but RX balance control may be adjusted to provide spatial displacement to aid user in quick signal identification.

NOTE

A priority transmission feature allows the pilot to override the copilot.

MUTING LOGIC

When transmitting, any music will be muted quickly, and will slowly return when transmission is completed. Music will also be muted when ICS or RX functions are active. The degree of muting is set at the time of installation.

The relative volume of the music can be changed from the panel by the knob marked with a musical note.

Below is a simple chart to aid in understanding audio switching in the NORMAL Operation mode.

		Effect on				
		Music	ICS	RX	Pilot TX	Copilot TX
Active function	Music	Active	Idle	Idle	Idle	Idle
	ICS	Muted	Active	Idle	Idle	Idle
	RX	Muted	Idle	Active	Idle	Idle
	Pilot TX	Muted	Muted	Idle	Active	Muted
	Copilot TX	Muted	Muted	Idle	Idle	Active

The following terms are used:

- Active Function being used
- Muted Functions that are overridden by the active condition
- Idle Functions that are not active, but still available for use

AUTOMATIC FAIL-SAFE

In the event of a power failure, automatic fail-safe operation will be activated. Fail-safe mode routes the pilot's phones, mic audio, and mic PTT directly to the COM radio.

During transmit mode, the pilot mic is directly connected to the transceiver mic. Mic bias is provided by the transceiver, not the AA83-001. The pilot TX keyline is directly connected to the transceiver. The sidetone audio is directly connected from the audio source to the pilot phones.

During receive mode, receive audio is directly connected from the audio source to the pilot phones.

In both modes, The copilot has no ICS, music, sideline, or receive functions.

NOTE

In Automatic Fail-safe mode, the receive/sidetone levels may require adjustment at the audio source.

The pilot should confirm that all aspects of Automatic Fail-safe operation are working before accepting the aircraft into service.

SECTION 911

BECKER ATC 4401 TRANSPONDER

Table of Contents

<i>Paragraph</i>		<i>Page</i>
911.1	GENERAL	911-3
911.1.1	Controls and indicators	911-4
911.1.2	Switching on the unit (pre-flight check)	911-4
911.1.3	Squawk selection	911-5
911.1.4	Flight operation in Mode A (transponder reply code only)	911-7
911.1.5	Flight operation in Mode A+C (reply code and altitude code)	911-7
911.1.6	Squawk Ident	911-7
911.1.7	Test	911-7
911.1.8	Configuration Mode	911-8
911.2	LIMITATIONS	911-8
911.3	EMERGENCY PROCEDURES	911-8
911.3.1	Important Codes	911-8
911.4	NORMAL PROCEDURES	911-8
911.5	PERFORMANCE	911-8

Left blank intentionally

911.1 GENERAL

The Becker panel mounted ATC 4401 Transponder is a radio transmitter and receiver that fulfills the role of the airborne beacon equipment according to the requirements of the Air Traffic Radar Beacon System (ATCRBS). Its functionality includes replying to ATCRBS Mode A and Mode C interrogations.

It operates on radar frequencies, receiving ground radar interrogations at 1030 MHz and transmitting a coded response of pulses to ground-based radar on a frequency of 1090 MHz. The ATC 4401 is equipped with IDENT capability that activates the Special Position Identification (SPI) pulse.

NOTE

The ATC 4401 owner accepts all responsibility for obtaining the proper license before using the transponder. Refer to Becker Pilot's Guide.

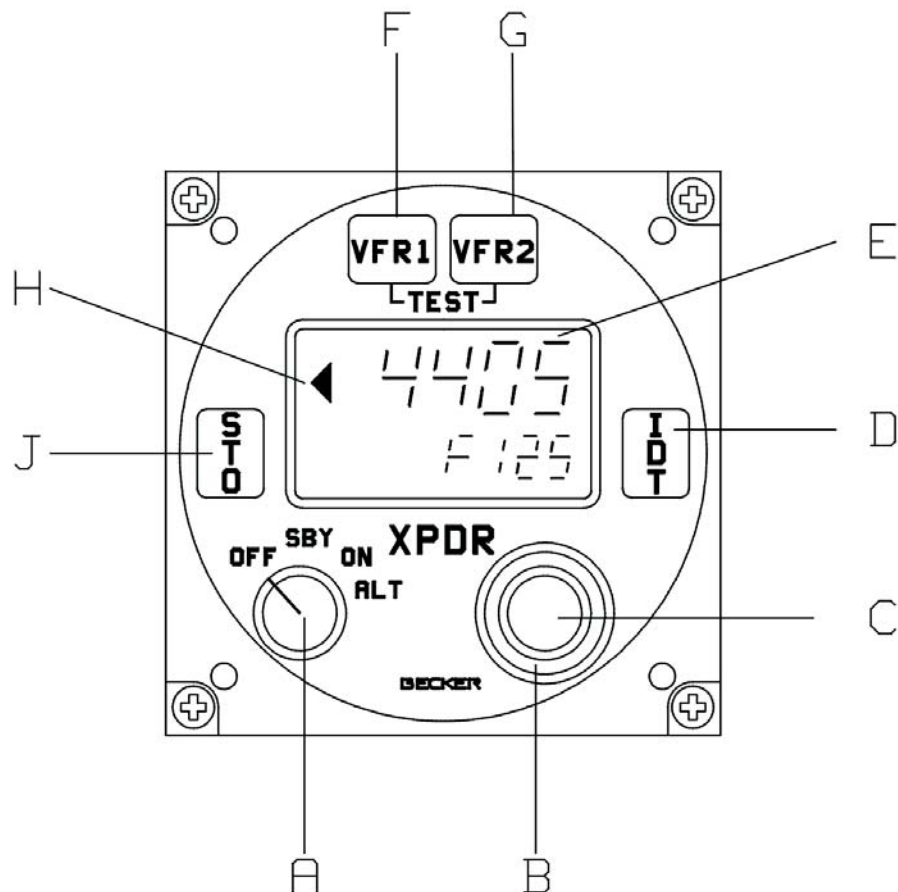

911.1.1 CONTROLS AND INDICATORS

A	OFF/SBY/ON/ALT rotary mode switch with 4 detent positions	OFF position : Transponder is switched off (expect panel lighting). SBY position : Standby mode is switched on. ON position : Mode A is switched on. ALT position : Mode A+C is switched on.
B	Rotary coding switch with 8 detents positions, continuously rotatable	Control of the cursor in one of the 4 code digits or from the display field
C	Rotary coding switch with 8 detents positions continuously rotatable	Setting the code digits from 0 to 7.
D	Ident push-button IDT	In Mode A and Mode A+C this triggers the transmission of an identification impulse additional to the Mode A reply code for approx. 18 seconds. During this time "Idt" appears in the bottom line of the LC display.
E	2-line LC display	Code indication (top line): Codes from 0000 to 7777 are possible. "Mode indication (bottom line) : SBY mode: ""SbY"" is displayed." "Mode A (ON): ""On"" appears in the display ""IDT"" is displayed the duration of the identification function." "Mode A+C (ALT): If a valid altitude is present, the flight level (height in steps of 100 ft) preceded by F (e.g. ""F241""= 24100 ft) appears. If no valid altitude code is present, ""FN-"" is displayed. The flight level display can be switched off in the configuration mode. ""Idt"" is displayed for the duration of the identification function."
F	Code push-button VFR1	Activates a first user-specific VFR code
G	Code push-button VFR2	Activates a second user-specific VFR code.
H	Reply indication REPLY	The triangle signals a Transponder reply.
J	Store push-button STO	Stores user-specific VFR codes or changes in the configuration mode

911.1.2 SWITCHING ON THE UNIT (PRE-FLIGHT CHECK)

- 1 Check that the circuit breaker is set and switch on the aircraft power supply .



Do not switch on the transponder if the motors or engines are being started or shut down.

- 2 Using mode switch (A), switch the transponder from **OFF** to **SBY**. A test then follows automatically for 3 seconds. The display is flashing with all digits and the unit is subject to a self-test simultaneously.

- 3 After the switch-on test has elapsed and no error-message is written in the display, the transponder switches to the mode set on the mode switch (A).

NOTE

The blind encoder is only powered if the transponder is not switched OFF (at least SBY). A blind encoder needs a warm-up time (sometimes a several minutes). Therefore although the solid state transponder needs no warm-up time, turn the transponder to SBY immediately after starting the engine.

911.1.3 SQUAWK SELECTION

- 1 The transponder remains switched in the standby mode until requested by the ground station (ATC) to transmit a code, e.g. „squawk alpha 6426“.
- 2 Using the double rotary switch (B,C) set the 4-digit code requested by ATC as follows :
 - a Using switch (B) move the cursor to the particular digit. Digits 0 to 7 can then be set using switch (C).

NOTES

If switch (B) is turned clockwise or counter-clockwise, the cursor is moved one position to the right or the left. The cursor appears only in the code display and is indicated by the flashing digit. If no cursor is visible, the first digit flashes after a clockwise rotation and the last digit after a counter-clockwise rotation. When the code is being changed in the ON or ALT position, the transponder temporarily switches to the standby mode.

The active time of the cursor and the rate of flashing can be changed in the configuration mode.

- b If the cursor is not moved again within of 3 seconds (can be changed in configuration mode) or if the cursor is moved so far that it can no longer be seen in the display field or the identification switch is pressed (in the ON or ALT mode), the code currently set is switched active.

NOTES

Whilst settings are taking place, the transmission branch of the transponder is inhibited to prevent unintentional transmission.

If only two digits were named by ATC, e.g. „Squawk alpha 64“, then a zero is to be used for positions three and four, i.e. „6400“.

- c The last used code is stored in each case and is also activated when the transponder is switched on.

SPECIAL VFR CODINGS

Two user-specific VFR codes can be stored and activated on the transponder.

- 1 Storing a new VFR code:
 - a Set the code to be stored in accordance with section B.
 - b Press store push-button **STO** (J), the set code then flashes.
 - c Press the **VFR1** push-button (F) or the **VFR2** push-button (G) within 3 seconds to store the code under the corresponding button.
 - d If neither button (F) or (G) is pressed within 3 seconds, the flashing stops and the storage operation is aborted.

NOTE

If one of the two buttons (F) or (G) is pressed without the STO button having been pressed beforehand, then the stored code allocated this button appears in the code display and is switched to active after 3 seconds (can be changed in the configuration mode). If the same button is again pressed within 3 seconds, the previous code appears.

- 2 Activation of the VFR codes:
 - a Press the **VFR** push-button **1** or **2** (F, G). The selected code is then displayed. After 3 seconds, the displayed code becomes activate and overwrites the previously-set reply code.
 - b Pressing button (F) or (G) again within 3 seconds reactivates the previously-set reply code.

NOTE

When the unit is delivered, the store buttons are not assigned a code. This means that if these buttons are pressed for 0.5 seconds, „—“ is shown in the code display and the transponder then switches back to the previously-active code.

IMPORTANT CODES:

- 1200 The VFR code for any altitude in the US (Refer to ICAO standards elsewhere)
- 7000 The VFR code commonly used in Europe (Refer to ICAO standards)
- 0021 The VFR code commonly used in Germany (default is set to 0021 at time of installation)
- 7500 Hijack code (Aircraft is subject to unlawful interference)
- 7600 Loss of communications
- 7700 Emergency
- 7777 Military interceptor operations (Never squawk this code)
- 0000 Military use (Not enterable)

Avoid selecting code 7500 and all codes in the 7600-7777 range. These trigger special indicators in automated facilities. Only the code 7500 will be decoded as the hijack code. An aircraft's transponder code (if available) is utilized to enhance the tracking capabilities of the ATC facility, therefore care should be taken when making routine code changes.

NOTE

Unintentional transmission of an emergency code is prevented in that the transponder replies are inhibited whilst the code is being set. This applies particularly where the new code is being set in the ON or ALT modes. Also if a special code is called up, no transponder reply takes place during the period in which the previous code can be reactivated (approximately 3 seconds).

911.1.4 FLIGHT OPERATION IN MODE A (TRANSPONDER REPLY CODE ONLY)

- 1 Select squawk as described above.
- 2 Set mode switch (A) from **SBY** to **ON**. The transponder immediately replies with the set code. A triangle on the left next to the code signals the transponder replies.

911.1.5 FLIGHT OPERATION IN MODE A+C (REPLY CODE AND ALTITUDE CODE)

- 1 Select squawk as described above.
- 2 ATC requests the transmission „alpha/charlie“ or „charlie“, switch the transponder to **ALT** using mode switch (A).
- 3 The transponder replies using the code set and in response to mode C requests it transmits the flight level of the aircraft to ATC. A triangle on the left next to the code signals the transponder replies.

911.1.6 SQUAWKIDENT

After a „squawk ident“ request from ATC, press Ident button **IDT** (D) briefly. This transmits an additional special pulse (SPI) for approx. 18 seconds, which enables the aircraft to be clearly identified on the radar screen of the controller. **'Idt'** appears in the bottom line of the LC display during this time.

911.1.7 TEST

The following different tests are integrated in the transponder or can be triggered at the transponder:

- 1 Automatic switching-on test, in which the display (E) is flashing with all digits for 3 seconds. The unit is subject to a self-test in this time.

- 2 A permanent test runs in the background of the transponder operation. The built-in FPGA organizes the required resources for this. The transmitter recognizes a mismatching or own abnormal behavior and delivers an alarm signal to the FPGA.
- 3 A further test of the unit is triggered, if the **VFR1** button (F) and **VFR2** button (G) are pressed simultaneously. At this test all segments must flash into display (E) as long as the buttons are pushed. Additionally the transmitter and evaluation are tested on correct function in the SBY, ON and ALT modes.
- 4 In case of a failure appears the report e.g. '**E10**' in the top line of the display. Switch OFF the transponder at such '**E**' fault indications.

911.1.8 CONFIGURATION MODE

The configuration Mode is used to set the unit on the ground and must not be called up in flight. Refer to BECKER's Pilot's Guide for further information.

911.2 LIMITATIONS

Not applicable.

911.3 EMERGENCY PROCEDURES

911.3.1 IMPORTANT CODES

7600 Loss of communications.

7500 Hijacking.

7700 Emergency (All secondary surveillance radar sites are ready to receive this code at all times).

See the Airman's Information Manual (AIM) for a detailed explanation of identification codes.

911.4 NORMAL PROCEDURES

Not applicable

911.5 PERFORMANCE

Not applicable

SECTION 912
BECKER ATC 6401 TRANSPONDER

Table of Contents

<i>Paragraph</i>		<i>Page</i>
912.1	GENERAL	912-3
912.1.1	Controls and Indicators	912-4
912.1.2	Switching on the Unit (pre-flight check)	912-4
912.1.3	Display	912-5
912.1.4	Squawk Selection	912-5
912.1.5	Squawk Ident	912-6
912.1.6	Selftests of the Unit (BITs)	912-6
912.1.7	Selection Mode	912-7
912.1.8	Flight Operation in Mode A/C/S (reply code and altitude code)	912-9
912.1.9	VFR Code Activation	912-10
912.1.10	Configuration Mode	912-10
912.2	LIMITATIONS	912-10
912.3	EMERGENCY PROCEDURES	912-10
912.3.1	Important Codes	912-10
912.4	NORMAL PROCEDURES	912-10
912.5	PERFORMANCE	912-10

Left blank intentionally

912.1 GENERAL

The Becker panel mounted BXP 6401 Transponder is a radio transmitter and receiver that fulfills the role of the airborne beacon equipment according to the requirements of the Air Traffic Radar Beacon System (ATCRBS). Its functionality includes replying to ATCRBS Mode A, C and Mode S interrogations.

It operates on radar frequencies, receiving ground radar interrogations at 1030 MHz and transmitting a coded response of pulses to ground-based radar on a frequency of 1090 MHz. The BXP 6401 is equipped with IDENT capability that activates the Special Position Identification (SPI) pulse.

NOTE

The BXP 6401 owner accepts all responsibility for obtaining the proper license before using the transponder. Refer to Becker Pilot's Guide.

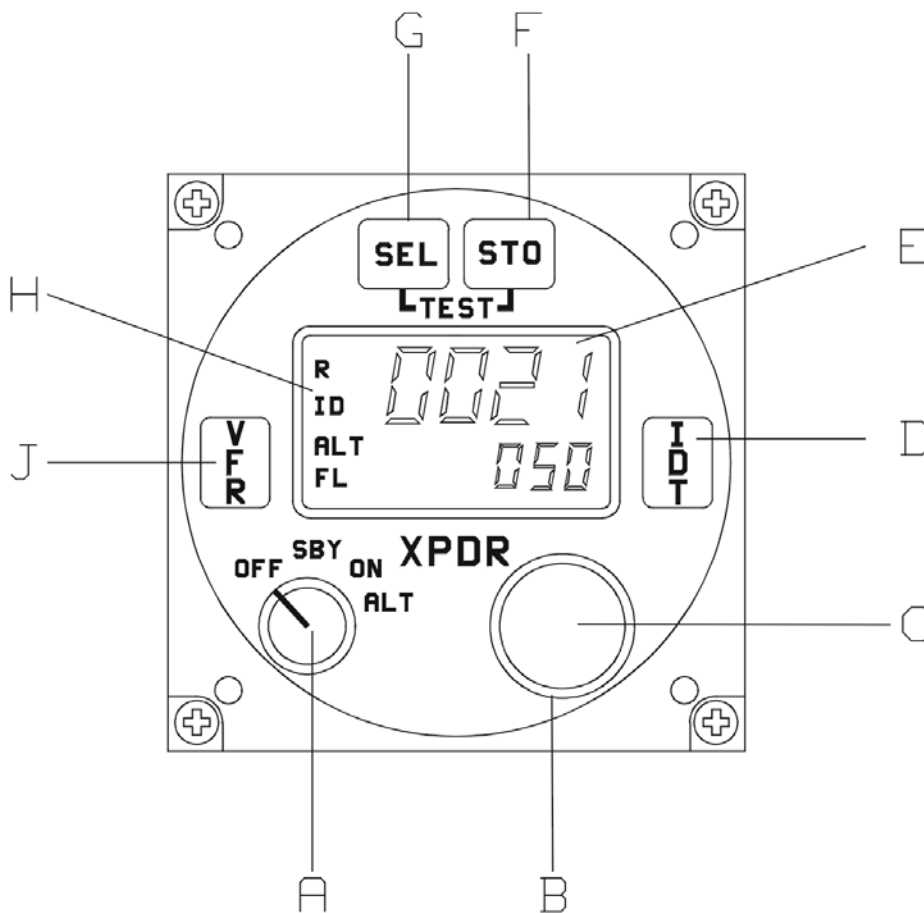

912.1.1 CONTROLS AND INDICATORS

A	Mode Selector	Rotary switch with 4 positions	OFF position : Transponder is switched off SBY position : Standby mode is switched on ON position: Mode A/S is switched on. Transmission of altitude information is suppressed ALT position: Mode A/C/S is switched on and the altitude information is transmitted.
B	Rotary switch	Rotary optical encoder (rotary mode of C)	Rotary switch to change settings (16 steps per turn)
C	Button	Push-button (mode of B)	Push to jump from digit to digit for settings or from one menu to the next; generally used as an enter key
D	IDT	Push-button	Activates the Special Identifier (SPI) in addition to the reply code for approx. 18 seconds; during this time "ID" appears in the LC display
E	Display, part 1	2-line LCD display	Displays the following informations: - code indication in the top row - flight level in the bottom row - various informations in the bottom row - additional indicators on the left side (see Ref. H)
F	STO	Push-button	Stores the selected values to the settings
G	SEL	Push-button	Opens and selects the menu
H	Display, part 2	LCD indicators	Displays additional indicators, (R for reply, ID for Ident, ALT for XPDR ALT mode or ON for XPDR ON mode, FL for flight level)
J	VFR	Push-button	Activates VFR code in the upper row of the display

912.1.2 SWITCHING ON THE UNIT (PRE-FLIGHT CHECK)

- 1 Check that the circuit breaker is set and switch on the aircraft power supply .



Do not switch on the transponder if the motors or engines are being started or shut down.

- 2 Using mode selector (A), switch the transponder from **OFF** to **SBY**. A test then follows automatically for 1 seconds. The display shows **'WAIT'** and the unit is subject to a self-test simultaneously.
- 3 After the switch-on test has elapsed and no error-message is written in the display, the transponder switches to the mode set on the mode selector (A).

NOTE

The blind encoder is only powered if the transponder is not switched OFF (at least SBY). A blind encoder needs a warm-up time (sometimes a several minutes). Therefore although the solid state transponder needs no warm-up time, turn the transponder to SBY immediately after starting the engine.

912.1.3 DISPLAY

Transponder's code is displayed in the top line using high readability font, at all times in modes SBY, ON, ALT. Depending on the configuration settings, the Aircraft Identification (AI) or Flight Number (FN) is displayed in the bottom line. Flight level is displayed in ALT mode in the bottom line of the display (altitude= FL x 100 in ft).

912.1.4 SQUAWK SELECTION

- 1 The transponder remains switched in the standby mode until requested by the ground station (ATC) to transmit a code, e.g. „squawk alpha 6426“.
- 2 Using the rotary switch (B) and the button (C) set the 4-digit code requested by ATC as follows:
 - a Using switch (C) move the cursor to the particular digit. Digits 0 to 7 can then be set using the rotary switch (B).

NOTES

Whilst settings are taking place, the transmission branch of the transponder is inhibited to prevent unintentional transmission.

If only two digits were named by ATC, e.g. „Squawk alpha 64“, then a zero is to be used for positions three and four, i.e. „6400“.

- b The last used code is stored in each case and is also activated when the transponder is switched on.

IMPORTANT CODES:

- 1200 The VFR code for any altitude in the US (Refer to ICAO standards elsewhere)
- 7000 The VFR code commonly used in Europe (Refer to ICAO standards)
- 0021 The VFR code commonly used in Germany (default is set to 0021 at time of installation)
- 7500 Hijack code (Aircraft is subject to unlawful interference)
- 7600 Loss of communications
- 7700 Emergency

7777 Military interceptor operations (Never squawk this code)

0000 Military use (Not enterable)

Avoid selecting code 7500 and all codes in the 7600-7777 range. These trigger special indicators in automated facilities. Only the code 7500 will be decoded as the hijack code. An aircraft's transponder code (if available) is utilized to enhance the tracking capabilities of the ATC facility, therefore care should be taken when making routine code changes.

NOTE

Unintentional transmission of an emergency code is prevented in that the transponder replies are inhibited whilst the code is being set. This applies particularly where the new code is being set in the ON or ALT modes. Also if a special code is called up, no transponder reply takes place during the period in which the previous code can be reactivated (approximately 3 seconds).

912.1.5 SQUAWKIDENT

After a „squawk ident“ request from ATC, press Ident button **IDT** (D) briefly. This transmits an additional special pulse (SPI) for approx. 18 seconds, which enables the aircraft to be clearly identified on the radar screen of the controller. '**Idt**' appears in the bottom line of the LC display during this time.

912.1.6 SELFTESTS OF THE UNIT (BITS)

The following different tests are integrated in the transponder or can be triggered at the transponder:

- 1 The IBIT (Initiated Built-in Test) can be activated in any mode (excluding the configuration mode) with the push of (F) and (G) at the same time. The action starts with the leading edge of the second pushed button. The IBIT works as follows in all modes:

The test starts with all available test routines including the transmitter test routine. During the test, '**IBIT**' is indicated on the display. The test takes not longer than 1 second. If the IBIT was successful, the XPDR switches immediately into the normal operating mode. During the IBIT any action from other switches is not recognized.

Negative results of the IBIT are indicated on the display with '**FAILURE**'. The transponder may be not switched into ON or ALT mode if any failure was found.

- 2 The CBIT (Continuous Built-in Test) works as follows:

The continuous BIT acts as a kind of watchdog during operation. Negative results of the CBIT are indicated on the display with '**FAILURE**'. In this case the transponder may be not switched into ON or ALT mode (display indication of operating mode set to '**SBY**') if any failure was found.

- 3 The PBIT (Power-on Built-in Test) works as follows:

The XPDR has a power-on BIT after switching on. During the PBIT any action from other switches are not accepted.

During the PBIT the XPDR is in the SBY mode but this is not indicated on the display. The operating mode indication on the display starts immediately after finalisation of the PBIT.

Negative results are indicated on the display with '**FAILURE**'. The transponder may be not switched into ON or ALT mode if any failure was found.

The PBIT takes not longer than 1 second. If the test was successful, the XPDR switches immediately into the normal operating mode.

912.1.7 SELECTION MODE

Press **SEL** button (G) and rotate encoder (B) for selection. In selection mode additional information is displayed in the bottom line of the display. Some of the data are editable, some are read only:

VFR	4096 code presetting	editable
AI	Aircraft Identifier (Tail Number)	fixed; read only from address module (an be replaced by FN). If no valid AI is stored, "-----" is displayed.
FN	Flight Number or Company Call Sign	editable; can be replaced by AI (fixed) by selecting "AI DEF"
AA	Aircraft Address (24-bit ICAO)	fixed; read only from address module (unique number for each aircraft)
MA	Maximum Airspeed	fixed; read only from address module
AT	Aircraft Type	fixed; read only from address module
CFG	Configuration	available in SBY mode only
INS	Installation setup	available in SBY mode only; protected by password

AIRCRAFT IDENTIFICATION (AI OR FN)

With flight plan:

The definition out of the flight plan: e.g. Flight Number or Company Call Sign

Without flight plan (VFR):

Tail Number (Call Sign)

The indication of '**AI**' in the bottom line of the display is in mode SBY and ON only if selected in configuration menu. The Aircraft Identifier (fixed) is available in any mode after pressing **SEL** button (G) and turning the rotary encoder (B). The default value for AI is the Tail Number of the aircraft and is stored in the Address Module.

If a flight plan exists, it has to be checked, which AI has to be used. If a Flight Number is assigned it has to be entered. If a Company Call Sign is mentioned, this has to be entered. To enter it see below. It will be stored in the EEPROM of the control head. In this case the indication on the display changes to '**FN**' (Flight Number). If the Call Sign (Tail Number) is mentioned, no change, as it is the default setting from the Address Module.

SETTING THE FLIGHT NUMBER:

- 1 Press **SEL** button (G) to enter the select mode.
- 2 Rotate (B) until '**AI**' is displayed.
- 3 Push (C) to switch to '**FN**'. The cursor is set on the first character.
- 4 Rotate (B) to change this character.
- 5 Push (C) to set the cursor to the next character.
- 6 Repeat steps 4 and 5 until the flight number is entered.
- 7 If the flight number consists of less than 7 characters, put a space at the end to fill the remaining characters with spaces.
- 8 Store the changes with **STO** button (F). For leaving the setting procedure without storing, push the **SEL** button (G).

NOTE

Aircraft Identifier / Flight Number consists of max. 7 characters (on the left- hand side oriented). No dashes or spaces shall be included. If the FN consists of less than 7 characters, the remaining characters on the right side shall be filled with spaces.

SWITCHING BACK TO DEFAULT AI:

- 1 Press **SEL** button (G) to enter the select mode.
- 2 Rotate (B) to the indication '**FN=XXXXXXXX**'.
- 3 First push on (C) indicates '**FN=AI DEF**' (inverted).
- 4 Can be set to '**AI=DEF**' with **STO** button (F).

CHANGING THE FLIGHT NUMBER:

- 1 Press **SEL** button (G).
- 2 Rotate (B) until '**FN**' is displayed.
- 3 Push (C) twice to enter the FN editing mode.
- 4 Change the FN as described above.

VFR CODE PRESETTING

Press the **SEL** button (G) to get into configuration mode (selection is indicated in the left bottom corner of the display under the operating mode indication).

- 1 Rotate (B) to the indication '**VFR=XXXX**'.
- 2 First push to button (C) now left digit of the code is inverted.
- 3 Now the digit can be changed with (B).
- 4 Second push to button (C) now next left digit of the code is inverted.
- 5 The next digit can be changed with (B)
- 6 and the same for next digits.
- 7 Fifth push to button (C) now again first digit is inverted.
- 8 Changes can be stored with **STO** button (F) at any time, inversion stops in this case.
- 9 A VFR code that was preset in this way can be activated as described in chapter *VFR Code Activation*.
- 10 A timeout for inversion (10 sec) is introduced if no action happens. Nothing stored, as long as (F) is not pressed.

NOTE

It is possible to leave the setting procedure with SEL button (G) at any time and normal mode is available then. Indication SEL on the display changes back to mode indication. If STO button (F) was not used, no change has been stored.

912.1.8 FLIGHT OPERATION IN MODE A/C/S (REPLY CODE AND ALTITUDE CODE)

- 1 When ATC requests the transmission „squawk“, switch the transponder to **ALT** using mode switch (A).

NOTE

In exceptions the altitude has to be turned off, i.e. switch the transponder to ON using mode switch (A).

- 2 The transponder replies using the selected Code and in response to mode C interrogation it transmits the altitude of the aircraft to ATC. A 'R' on the left next to the Code on the display signals the transponder replies.

NOTE

Switch the transponder to Stand-by (SBY), if the Code has to be changed. Otherwise it could happen that a Code with a special meaning (see chapter K, e.g. hijack) will be transmitted and unwanted actions could take place.

912.1.9 VFR CODE ACTIVATION

- 1 Press the **VFR** push-button (J). The preselected code is then displayed. After 3 seconds, the displayed code gets active and overwrites the previously-set reply code.
- 2 Pressing push-button (J) again within 3 seconds reactivates the previously-set reply code.

NOTE

When the unit is delivered, the VFR button is not assigned a code. This means that if this button is pressed for 0.5 seconds, „—“ is shown in the code display and the transponder then switches back to the previously-active code.

912.1.10 CONFIGURATION MODE

The configuration mode is available from SBY mode only. To get into configuration mode press button **SEL** (G), turn rotary encoder (B) until '**CFG**' appears in the bottom row of the display. Refer to BECKER's Pilot's Guide for available options.

912.2 LIMITATIONS

Not applicable.

912.3 EMERGENCY PROCEDURES

912.3.1 IMPORTANT CODES

7600 Loss of communications.

7500 Hijacking.

7700 Emergency (All secondary surveillance radar sites are ready to receive this code at all times).

See the Airman's Information Manual (AIM) for a detailed explanation of identification codes.

912.4 NORMAL PROCEDURES

Not applicable

912.5 PERFORMANCE

Not applicable

SECTION 913
GARMIN GTX 327 TRANSPONDER

Table of Contents

<i>Paragraph</i>		<i>Page</i>
913.1	GENERAL	913-3
913.1.1	Mode Selection Keys	913-3
913.1.2	Code Selection	913-4
913.1.3	Keys for other GTX 327 Functions	913-4
913.2	LIMITATIONS	913-6
913.3	EMERGENCY PROCEDURES	913-6
913.3.1	Important Codes	913-6
913.4	NORMAL PROCEDURES	913-6
913.5	PERFORMANCE	913-6

Left blank intentionally

913.1 GENERAL

The GARMIN GTX 327 is a panel-mounted TSO.d transponder with the addition of timing functions. The transponder is a radio transmitter and receiver that operates on radar frequencies, receiving ground radar interrogations at 1030 MHz and transmitting a coded response of pulses to ground-based radar on a frequency of 1090 MHz.



NOTE

The GTX 327 owner accepts all responsibility for obtaining the proper license before using the transponder.

The coverage you can expect from the GTX 327 is limited to „line of sight“. Low altitude or aircraft antenna shielding by the aircraft itself may result in reduced range. Range can be improved by climbing to a higher altitude. It may be possible to minimize antenna shielding by locating the antenna where dead spots are only noticed during abnormal flight attitudes.



The GTX 327 should be turned off before starting or shutting down aircraft engine.

The GTX 327 Transponder is powered on by pressing the **STBY**, **ALT** or **ON** keys, or by the **AVIONIC** switch. After power on a start-up page will be displayed while the unit performs a self test.

913.1.1 MODE SELECTION KEYS

OFF

Powers off the GTX 327.

STBY

Powers on the transponder in standby mode. At power on the last active identification code will be selected. When in standby mode, the transponder will not reply to any interrogations.

ON

Powers on the transponder in Mode A. At power on the last active identification code will be selected. In this mode the transponder replies to interrogations, as indicated by the Reply Symbol. Replies do not include altitude information.

ALT

Powers on the transponder in Mode A and Mode C. At power on the last active identification code will be selected. In ALT mode, the transponder replies to identification and altitude interrogations, as indicated by the Reply Symbol. Replies to altitude interrogations include standard pressure altitude received from a separate encoder.

913.1.2 CODE SELECTION

Code selection is done with eight keys (**0-7**) that provide 4,096 active identification codes. Pushing one of these keys begins the code selection sequence. The new code will not be activated until the fourth digit is entered. Pressing the **CLR** key will move the cursor back to the previous digit. Pressing the **CLR** key when the cursor is on the first key of the code, or pressing the **CRSR** key during code entry, will remove the cursor and cancel data entry, restoring the previous code. The numbers **8** and **9** are not used for code entry, only for entering a Count Down time, and in Configuration Mode.

IMPORTANT CODES:

1200 The VFR code for any altitude in the US (Refer to ICAO standards elsewhere)

7000 The VFR code commonly used in Europe (Refer to ICAO standards)

0021 The VFR code commonly used in Germany (default is set to 0021 at time of installation)

7500 Hijack code (Aircraft is subject to unlawful interference)

7600 Loss of communications

7700 Emergency

7777 Military interceptor operations (Never squawk this code)

0000 Military use (Not enterable)

Care should be taken not to select the code 7500 and all codes in the 7600-7777 range, which trigger special indicators in automated facilities. Only the code 7500 will be decoded as the hijack code. An aircraft's transponder code (if available) is utilized to enhance the tracking capabilities of the ATC facility, therefore care should be taken when making routine code changes.

913.1.3 KEYS FOR OTHER GTX 327 FUNCTIONS

IDENT

Pressing the **IDENT** key activates the Special Position Identification (SPI) Pulse for 18 seconds, identifying your transponder return from others on the air traffic controller's screen. The word '**IDENT**' will appear in the upper left corner of the display while the IDENT mode is active.

VFR

Sets the transponder code to the pre-programmed VFR code selected in the Configuration Mode. Pressing the **VFR** key again will restore the previous identification code.

START/STOP

Starts and stops the Count Up and Count Down timers.

CRSR

Initiates entry of starting time for the Count Down timer and cancels transponder code entry.

CLR

Resets the Count Up and Count Down timers and cancels the previous keypress during code selection.

8

Reduces Contrast and Display Brightness when the respective pages are displayed. Also enters the number eight into the Count Down timer.

9

Increases Contrast and Display Brightness when the respective pages are displayed. Also enters the number nine into the Count Down timer.

FUNC

Changes the page shown on the right side of the display. Displayed data includes Pressure Altitude, Flight Time, Count Up timer, Count Down timer, and may include Contrast and Display Brightness, depending on configuration (refer to the screen description below):

SCREEN DESCRIPTION:

'PRESSURE ALT'

Displays the altitude data supplied to GTX 327 in feet, hundreds of feet (i.e., flight level), or meters, depending on configuration.

'FLIGHT TIME'

Displays the Flight Time, which is controlled by the **START/STOP** key.

'COUNT UP TIMER'

Controlled by the **START/STOP** and **CLR** keys.

'COUNT DOWN TIMER'

Controlled by **START/STOP**, **CLR**, and **CRSR** keys. The initial Count Down time is entered with the **0 - 9** keys.

'CONTRAST'

This page is only displayed if manual contrast mode is selected in Configuration Mode. Contrast is controlled by the **8** and **9** keys.

'DISPLAY'

This page is only displayed if manual backlighting mode is selected on Configuration Mode. Backlighting is controlled by the **8** and **9** keys.

913.2 LIMITATIONS

Not applicable.

913.3 EMERGENCY PROCEDURES

913.3.1 IMPORTANT CODES

7600 Loss of communications.

7500 Hijacking.

7700 Emergency (All secondary surveillance radar sites are ready to receive this code at all times).

See the Airman's Information Manual (AIM) for a detailed explanation of identification codes.

913.4 NORMAL PROCEDURES

Not applicable.

913.5 PERFORMANCE

Not applicable.

SECTION 914

GARMIN GTX 328 TRANSPONDER

Table of Contents

<i>Paragraph</i>		<i>Page</i>
914.1	GENERAL	914-3
914.1.1	Mode Selection Keys	914-4
914.1.2	Code Selection	914-4
914.1.3	Keys for other GTX 328 Functions	914-5
914.1.4	Function Display	914-5
914.1.5	Configuration Mode	914-6
914.1.6	Altitude trend indicator	914-6
914.1.7	Failure Annunciation	914-6
914.2	LIMITATIONS	914-7
914.3	EMERGENCY PROCEDURES	914-7
914.3.1	Important Codes	914-7
914.4	NORMAL PROCEDURES	914-7
914.5	PERFORMANCE	914-7

Left blank intentionally

914.1 GENERAL

The Garmin GTX 328 panel mounted Mode S VFR Transponder is a radio transmitter and receiver that fulfills the role of the airborne beacon equipment according to the requirements of the Air Traffic Radar Beacon System (ATCRBS). Its functionality includes replying to ATCRBS Mode A and C and Mode S interrogations. The Mode S function will allow the ground station to individually select the aircraft by its Aircraft Address assigned to the aircraft by the aviation agency.



It operates on radar frequencies, receiving ground radar interrogations at 1030 MHz and transmitting a coded response of pulses to ground-based radar on a frequency of 1090 MHz. The GTX 328 is equipped with IDENT capability that activates the Special Position Identification (SPI) pulse for 18 seconds. Mode S transmit/receive capability also requires 1090 MHz transmitting and 1030 MHz receiving for Mode S functions. In addition to displaying the code, reply symbol and mode of operation, the GTX 328 screen will display pressure altitude and timer functions. The displayed pressure altitude may not agree with the aircraft's baro-corrected altitude under non standard conditions. The unit also features flight timers.

The Traffic Information Service (TIS) is not available in this installation.

NOTE

The GTX 328 owner accepts all responsibility for obtaining the proper license before using the transponder.

The coverage you can expect from the GTX 328 is limited to „line of sight“. Low altitude or aircraft antenna shielding by the aircraft itself may result in reduced range. Range can be improved by climbing to a higher altitude. It may be possible to minimize antenna shielding by locating the antenna where dead spots are only noticed during abnormal flight attitudes.



The GTX 328 should be turned off before starting or shutting down aircraft engine.

The GTX 328 Transponder is automatically powered on by the respective **AVIONIC** switch or when previously manually powered off while **AVIONIC** switch is on by pressing the **STBY**, **ALT** or **ON** keys. After power on, a start-up page will be displayed while the unit performs a self test.

This supplement is written for software version 5.00 or later, and is not suitable for earlier software versions. Some differences in operation may be observed when comparing the information in this supplement to later software versions.

Verify the information herein with the GTX 328 pilot's guide (PN 190-00420-03 applicable revision) you received with your transponder. There you find also further information.

914.1.1 MODE SELECTION KEYS

OFF

Powers off the GTX 328. Pressing STBY, ON or ALT Key powers on the transponder displaying the last active identification code.

STBY

Selects the standby mode. When in standby mode, the transponder will not reply to any interrogations.

ON

Selects Mode A. In this mode the transponder replies to interrogations, as indicated by the Reply Symbol. Replies do not include altitude information.

ALT

Selects Mode A and Mode C. In ALT mode, the transponder replies to identification and altitude interrogations as indicated by the Reply Symbol. Replies to altitude interrogations include the standard pressure altitude received from an external altitude source, which is not adjusted for barometric pressure. Any time the function ON or ALT is selected the transponder becomes an active part of the Air Traffic Control Radar Beacon System (ATCRBS). The transponder also responds to interrogations from TCAS equipped aircraft.

914.1.2 CODE SELECTION

Code selection is done with eight keys (**0 – 7**) providing 4,096 active identification codes. Pushing one of these keys begins the code selection sequence. Digits that are not yet entered appear as dashes. The new code is activated when the fourth digit is entered. Pressing the **CLR** Key moves the cursor back to the previous digit. Pressing the **CLR** Key when the cursor is on the first digit of the code, or pressing the **CRSR** Key during code entry, removes the cursor and cancels data entry, restoring the previous code. Press the **CLR** Key up to five seconds after code entry is complete to return the cursor to the fourth digit. The numbers **8** and **9** are not used for code entry, only for entering a Count Down time, and contrast and display brightness.

IMPORTANT CODES:

- 1200 The VFR code for any altitude in the US (Refer to ICAO standards elsewhere)
- 7000 The VFR code commonly used in Europe (Refer to ICAO standards)
- 7500 Hijack code (Aircraft is subject to unlawful interference)
- 7600 Loss of communications
- 7700 Emergency
- 7777 Military interceptor operations (Never squawk this code)
- 0000 Military use (Not enterable)

Avoid selecting codes 0000, 7500, and all codes in the 7600-7777 range. These codes trigger special indicators in automated facilities. An aircraft's transponder code is used for ATC tracking purposes, therefore exercise care when making routine code changes!

914.1.3 KEYS FOR OTHER GTX 328 FUNCTIONS

IDENT

Pressing the **IDENT** Key activates the Special Position Identification (SPI) Pulse for 18 seconds, identifying your transponder return from others on the air traffic controller's screen. The word 'IDENT' will appear in the upper left corner of the display while the IDENT mode is active.

VFR

Sets the transponder code to the pre-programmed VFR code selected in Configuration Mode (this is set to 7000 at the factory). Pressing the **VFR** Key again restores the previous identification code.

FUNC

Changes the page shown on the right side of the display. Display data includes Pressure Altitude, Flight Time, Count Up and Count Down timers. Also displays Contrast and Display (if manual control and backlighting is selected in the installation configuration).

START/STOP

Starts and stops the Count Up, Count Down and Flight timers.

CRSR

Initiates starting time entry for the Count Down timer and cancels transponder code entry.

CLR

Resets the Count Up, Count Down and Flight timers. Cancels the previous keypress during code selection and Count Down entry. Returns cursor to the fourth code digit within five seconds after entry.

8

Reduces Contrast and Display Brightness when the respective fields are displayed (if manual control is selected in the installation configuration) and enters the number eight into the Count Down timer.

9

Increases Contrast and Display Brightness when the respective fields are displayed (if manual control is selected in the installation configuration) and enters the number nine into the Count Down timer.

914.1.4 FUNCTION DISPLAY

'PRESSURE ALT'

Displays the altitude data supplied to the GTX 328 in feet, hundreds of feet (i.e., flight level), or meters, (dependent upon installation configuration).

'FLIGHT TIME'

Timer start is configured as either Manual or Automatic. When Manual, displays the Flight Time, controlled by the **START/STOP** and **CLR** keys. When Automatic, the timer begins when take off is sensed.

'ALTITUDE MONITOR'

The ALTITUDE MONITOR function is not available in this installation.

'OAT/DALT'

The OAT/DALT function is not available in this installation (no temperature input).

'COUNT UP TIMER'

Controlled by the **START/STOP** and **CLR** keys. Pressing the **CLR** key zeros the display.

'COUNT DOWN TIMER'

Controlled by **START/STOP**, **CLR**, and **CRSR** keys. The initial Count Down time is entered with the **0 - 9** keys. Pressing the **CLR** key resets the timer to the initial value.

'STBY'

The transponder will not reply to any interrogations.

'GND'

This page is not active.

'CONTRAST'

This page is only displayed if manual contrast mode is selected during installation configuration. Contrast is controlled by the **8** and **9** keys.

'DISPLAY'

This page is only displayed if manual backlighting mode is selected during installation configuration. Backlighting is controlled by the **8** and **9** keys.

914.1.5 CONFIGURATION MODE

The configuration mode is not active.

The GTX 328's options are normally set at time of installation. To request any changes of the GTX 328 parameters, contact an authorized Garmin Aviation Service Center.

914.1.6 ALTITUDE TREND INDICATOR

When the **'PRESSURE ALT'** page is displayed, an arrow may be displayed to the right of the altitude, indicating that the altitude is increasing or decreasing. One of two sizes of arrows may be displayed depending on the vertical speed rate. The sensitivity of these arrows is set by an authorized Garmin Aviation Service Center.

914.1.7 FAILURE ANNUNCIATION

If the unit detects an internal failure, the screen displays **'FAIL'**. When **'FAIL'** is annunciated no transponder data is transmitted.

914.2 LIMITATIONS

Not applicable.

914.3 EMERGENCY PROCEDURES

914.3.1 IMPORTANT CODES

7600 Loss of communications.

7500 Hijacking.

7700 Emergency (All secondary surveillance radar sites are ready to receive this code at all times).

See the Airman's Information Manual (AIM) for a detailed explanation of identification codes.

914.4 NORMAL PROCEDURES

Not applicable.

914.5 PERFORMANCE

Not applicable.

Left blank intentionally

SECTION 915
GARMIN GTX 330 TRANSPONDER

Table of Contents

<i>Paragraph</i>		<i>Page</i>
915.1	GENERAL	915-3
915.1.1	Mode Selection Keys	915-4
915.1.2	Code Selection	915-4
915.1.3	Keys for other GTX 330 Functions	915-5
915.1.4	Function Display	915-5
915.1.5	Configuration Mode	915-6
915.1.6	Altitude trend indicator	915-6
915.1.7	Failure Annunciation	915-6
915.2	LIMITATIONS	915-7
915.3	EMERGENCY PROCEDURES	915-7
915.3.1	Important Codes	915-7
915.4	NORMAL PROCEDURES	915-7
915.5	PERFORMANCE	915-7

Left blank intentionally

915.1 GENERAL

The Garmin GTX 330 panel mounted Mode S Transponder is a radio transmitter and receiver that fulfills the role of the airborne beacon equipment according to the requirements of the Air Traffic Radar Beacon System (ATCRBS). Its functionality includes replying to ATCRBS Mode A and C and Mode S interrogations. The Mode S function will allow the ground station to individually select the aircraft by its Aircraft Address assigned to the aircraft by the aviation agency.



It operates on radar frequencies, receiving ground radar interrogations at 1030 MHz and transmitting a coded response of pulses to ground-based radar on a frequency of 1090 MHz. The GTX 330 is equipped with IDENT capability that activates the Special Position Identification (SPI) pulse for 18 seconds. Mode S transmit/receive capability also requires 1090 MHz transmitting and 1030 MHz receiving for Mode S functions. In addition to displaying the code, reply symbol and mode of operation, the GTX 330 screen will display pressure altitude and timer functions. The displayed pressure altitude may not agree with the aircraft's baro-corrected altitude under non standard conditions. The unit also features flight timers.

The Traffic Information Service (TIS) is not available in this installation.

NOTE

The GTX 330 owner accepts all responsibility for obtaining the proper license before using the transponder.

The coverage you can expect from the GTX 330 is limited to „line of sight“. Low altitude or aircraft antenna shielding by the aircraft itself may result in reduced range. Range can be improved by climbing to a higher altitude. It may be possible to minimize antenna shielding by locating the antenna where dead spots are only noticed during abnormal flight attitudes.



The GTX 330 should be turned off before starting or shutting down aircraft engine.

The GTX 330 Transponder is automatically powered on by the respective **AVIONIC** switch or when previously manually powered off while **AVIONIC** switch is on by pressing the **STBY**, **ALT** or **ON** keys. After power on, a start-up page will be displayed while the unit performs a self test.

This supplement is written for software version 3.00 or later, and is not suitable for earlier software versions. Some differences in operation may be observed when comparing the information in this supplement to later software versions. Verify the information herein with the GTX 330 pilot's guide (PN 190-00207-00 applicable revision) you received with your transponder.

915.1.1 MODE SELECTION KEYS

OFF

Powers off the GTX 330.

STBY

Selects the standby mode displaying the last active identification code. When in standby mode, the transponder will not reply to any interrogations.

ON

Selects Mode A. At power on the last active identification code will be selected. In this mode the transponder replies to interrogations, as indicated by the Reply Symbol. Replies do not include altitude information.

ALT

Powers on the transponder in Mode A and Mode C. At power on the last active identification code will be selected. In ALT mode, the transponder replies to identification and altitude interrogations, as indicated by the Reply Symbol. Replies to altitude interrogations include standard pressure altitude received from a separate encoder.

915.1.2 CODE SELECTION

Code selection is done with eight keys (**0 - 7**) that provide 4,096 active identification codes. Pushing one of these keys begins the code selection sequence. The new code will not be activated until the fourth digit is entered. Pressing the **CLR** key will move the cursor back to the previous digit. Pressing the **CLR** key when the cursor is on the first key of the code, or pressing the **CRSR** key during code entry, will remove the cursor and cancel data entry, restoring the previous code. You may press the **CLR** key up to five seconds after code entry is complete to return the cursor to the fourth digit. The numbers **8** and **9** are not used for code entry, only for entering a Count Down time, contrast and display brightness, and in the Configuration Mode.

IMPORTANT CODES:

1200 The VFR code for any altitude in the US (Refer to ICAO standards elsewhere)

7000 The VFR code commonly used in Europe (Refer to ICAO standards)

7500 Hijack code (Aircraft is subject to unlawful interference)

7600 Loss of communications

7700 Emergency

7777 Military interceptor operations (Never squawk this code)

0000 Military use (Not enterable)

Avoid selecting code 7500 and all codes in the 7600-7777 range. These trigger special indicators in automated facilities. Only the code 7500 will be decoded as the hijack code. An aircraft's transponder code (if available) is utilized to enhance the tracking capabilities of the ATC facility, therefore care should be taken when making routine code changes.

915.1.3 KEYS FOR OTHER GTX 330 FUNCTIONS

IDENT

Pressing the IDENT key activates the Special Position Identification (SPI) Pulse for 18 seconds, identifying your transponder return from others on the air traffic controller's screen. The word 'IDENT' will appear in the upper left corner of the display while the IDENT mode is active.

VFR

Pressing the VFR key sets the transponder code to the pre-programmed VFR code selected in the Configuration Mode. Pressing the VFR key again will restore the previous identification code.

FUNC

Pressing the FUNC key changes the page shown on the right side of the display. Displayed data includes Pressure Altitude, Flight Time, Count Up timer, Count Down timers. In the Configuration Mode, steps through function pages.

START/STOP

Starts and stops the Count Up, Count Down and flight timers. In the Configuration Mode, steps through functions in reverse.

CRSR

Initiates starting time entry for the Count Down timer and cancels transponder code entry. Returns cursor to last code digit within five seconds after entry. Selects changeable fields in Configuration Mode.

CLR

Resets the Count Up and Count Down timers. Cancels the previous keypress during code selection and Count Down entry. Returns cursor to last code digit within five seconds after entry. Used in Configuration Mode.

8

Reduces Contrast and Display Brightness when the respective pages are displayed and enters the number eight into the Count Down timer. Used in Configuration Mode.

9

Increases Contrast and Display Brightness when the respective pages are displayed. Also enters the number nine into the Count Down timer. Used in Configuration Mode.

915.1.4 FUNCTION DISPLAY

'PRESSURE ALT'

Displays the altitude data supplied to GTX 330 in feet, hundreds of feet (i.e., flight level), or meters, depending on configuration. An arrow to the right of the altitude indicates that the airplane is climbing or descending.

'FLIGHT TIME'

Displays the Flight Time controlled by the **START/STOP** and **CLR** keys when Automated Airborne Determination is configured as normal.

'ALTITUDE MONITOR'

The ALTITUDE MONITOR function is not available in this installation.

'OAT/DALT'

The OAT/DALT function is not available in this installation (no temperature input).

'COUNT UP TIMER'

The count up timer is controlled by the **START/STOP** and **CLR** keys. Pressing the **CLR** key zeros the display.

'COUNT DOWN TIMER'

The count down timer is controlled by **START/STOP**, **CLR**, and **CRSR** keys. The initial Count Down time is entered with the **0 - 9** keys. Pressing the **CLR** key resets the timer to the initial value.

'STBY'

The transponder will not reply to any interrogations.

'GND'

This page is not active.

'CONTRAST'

This page is only displayed if manual contrast mode is selected in Configuration Mode. Contrast is controlled by the **8** and **9** keys.

'DISPLAY'

This page is only displayed if manual backlighting mode is selected on Configuration Mode. Backlighting is controlled by the **8** and **9** keys.

915.1.5 CONFIGURATION MODE

The configuration is normally set at time of installation, including the unique Mode S aircraft address. The configuration Mode should not be used during flight. Refer to the GTX 330 pilot's guide (PN 190-00207-00 applicable revision) you received with your transponder.

915.1.6 ALTITUDE TREND INDICATOR

When the **'PRESSURE ALT'** page is displayed, an arrow is displayed to the right of the altitude, indicating that the altitude is increasing or decreasing. One of two sizes of arrows is displayed depending on the rate of climb/&descent. The sensitivity of these arrows is set using the Configuration Mode vertical speed rate.

915.1.7 FAILURE ANNUNCIATION

If the unit detects an internal failure, the screen displays **'FAIL'**.

915.2 LIMITATIONS

Not applicable.

915.3 EMERGENCY PROCEDURES

915.3.1 IMPORTANT CODES

7600 Loss of communications.

7500 Hijacking.

7700 Emergency (All secondary surveillance radar sites are ready to receive this code at all times).

See the Airman's Information Manual (AIM) for a detailed explanation of identification codes.

915.4 NORMAL PROCEDURES

Not applicable.

915.5 PERFORMANCE

Not applicable.

Left blank intentionally

SECTION 916
GARMIN GNC 420W/GNS 430W

Table of Contents

<i>Paragraph</i>		<i>Page</i>
916.1	GENERAL	916-3
916.2	LIMITATIONS	916-3
916.2.1	Placards	916-4
916.3	EMERGENCY/ABNORMAL PROCEDURES	916-4
916.3.1	Emergency Procedures	916-4
916.3.2	Abnormal Procedures	916-4
916.4	NORMAL PROCEDURES	916-5
916.5	PERFORMANCE	916-5
916.6	WEIGHT & CENTER OF GRAVITY	916-5
916.7	SYSTEM DESCRIPTION	916-5
916.7.1	Key and Knob Functions	916-5
916.7.2	Default Nav Page	916-7

Left blank intentionally

916.1 GENERAL

The Garmin GNC 420W/GNS 430W GPS Navigator is a panel-mounted unit that contains a GPS receiver for GPS navigation plus VHF Com radio in an integrated unit with a moving map and color display. The GNC 420W/GNS 430W features a graphical display which may also be used to depict terrain data. The GNS 430W also features NAV functionality.

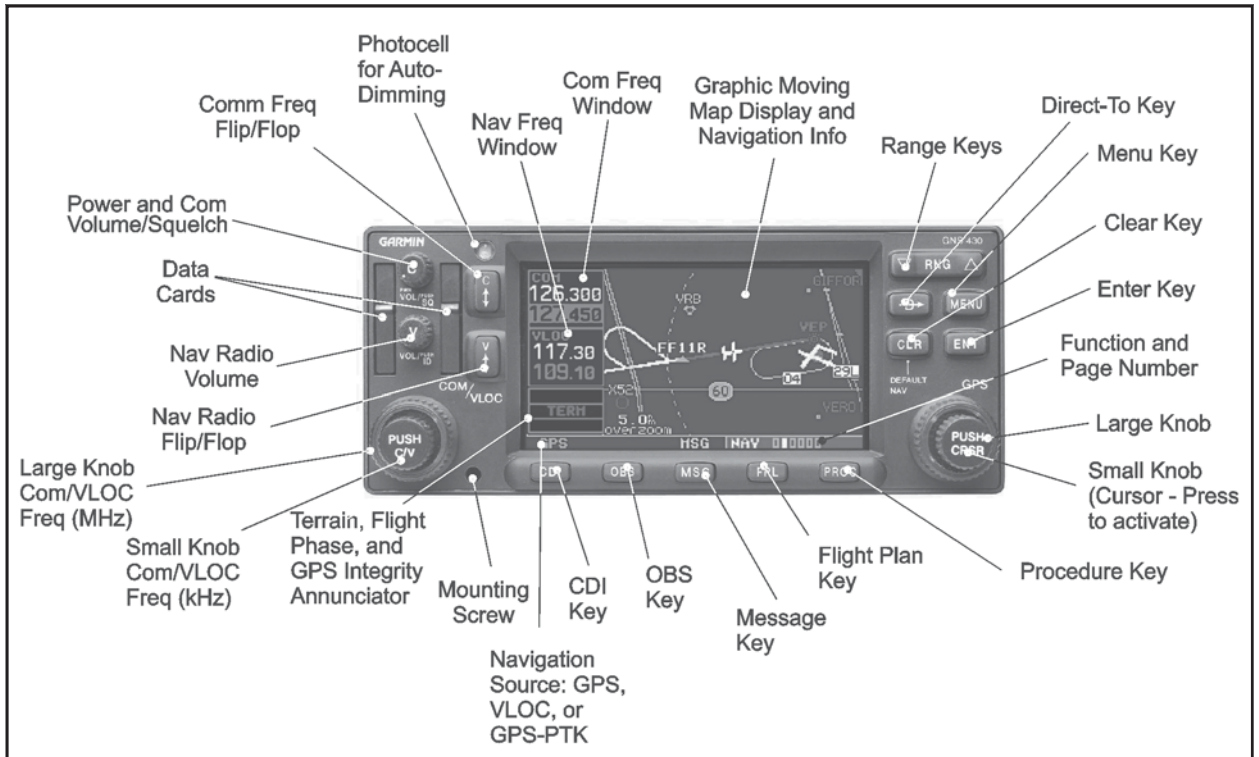

This supplement is written for main software version 3.00 and GPS software version 3.0 and is not suitable for earlier software versions. Some differences in operation may be observed when comparing the information in this supplement to later software versions. Verify the information herein with the 400W Series Pilot's Guide & Reference (P/N 190-00356-00 applicable Revision) you received with your unit. There you will also find further information.

916.2 LIMITATIONS

The system must utilize main software version 3.00 and GPS software version 3.0 or later FAA approved versions. A valid and compatible database must be installed and contain current data.

The information provided by the GNC 420W/GNS 430W is for situational awareness only and should not be relied upon for navigation.

916.2.1 PLACARDS

**GARMIN GPS
limited to VFR use only**

(In the clear view of the pilot)

GPS

(Next to the GNC 420W/GNS 430W circuit breaker)

916.3 EMERGENCY/ABNORMAL PROCEDURES

916.3.1 EMERGENCY PROCEDURES

Not affected.

916.3.2 ABNORMAL PROCEDURES

GPS NAVIGATION INFORMATION NOT AVAILABLE OR INVALID

If GNC 420W/GNS 430W GPS navigation information is not available or invalid, utilize remaining operational navigation equipment as appropriate.

LOSS OF INTEGRITY MONITORING

If Loss of Integrity Monitoring message is displayed, revert to an alternate means of navigation appropriate to the route and phase of flight or periodically cross-check the GPS guidance to other, approved means of navigation.

LOSS OF GPS SIGNAL DURING ACROBATICS

When performing acrobatics the GPS signal can get lost.

1. Reset (switch OFF and ON) the unit to regain the GPS signal.

SEARCHING A NEARBY AIRPORT

To select a nearby airport as a direct-to waypoint:

1. Press the **direct-to** key. The select direct-to waypoint page will appear, with the waypoint identifier field highlighted.
2. Turn the large right knob to highlight the nearest airport (NRST) field.

3. Turn the **small right** knob to display a window showing up to nine nearby airports.
4. Continue turning the small right knob to scroll through the list and highlight the desired airport.
5. Press ENT to confirm the selected airport, and ENT to activate the direct-to function.

916.4 NORMAL PROCEDURES

TO ACTIVATE AN EXISTING FLIGHT PLAN:

1. Press FPL and turn the small right knob to display the flight plan catalog.
2. Press the small right knob to activate the cursor.
3. Turn the large right knob to highlight the desired flight plan and press MENU to display the flight plan catalog options.
4. Turn the large right knob to highlight „Activate Flight Plan?“ and press ENT.
5. Press and hold the CLR key to open the default NAV page.

916.5 PERFORMANCE

Not affected.

916.6 WEIGHT & CENTER OF GRAVITY

Refer to the equipment list in Section 6 of this Handbook.

916.7 SYSTEM DESCRIPTION

916.7.1 KEY AND KNOB FUNCTIONS

LEFT-HAND KEYS AND KNOBS

The COM power/volume knob controls unit power and communications radio volume. Press momentarily to disable automatic squelch control. In the GPS 420W, this control is used only for power.

The large left knob (COM/VLOC) is used to tune the megahertz (MHz) value (to the left of the decimal point) of the standby frequency for the communications transceiver (COM) or the VLOC receiver, whichever is currently selected by the tuning cursor.

The small left knob (COM/VLOC) is used to tune the kilohertz (kHz) value (to the right of the decimal point) of the standby frequency for the communications transceiver (COM) or the VLOC receiver, whichever is currently selected by the tuning cursor. Press this knob momentarily to toggle the tuning cursor between the COM and VLOC frequency fields.

The COM flip-flop key is used to swap the active and standby COM frequencies. Press and hold to select emergency channel (121.500 MHz).

RIGHT-HAND KEYS AND KNOBS

The range key (RNG) allows you to select the desired map scale. Use the up arrow side of the key to zoom out to a larger area, or the down arrow side to zoom in to a smaller area.

The direct-to key provides access to the direct-to function, which allows you to enter a destination waypoint and establishes a direct course to the selected destination.

The MENU key displays a context-sensitive list of options. This options list allows you to access additional features or make settings changes which relate to the currently displayed page.

The clear key (CLR) is used to erase information or cancel an entry. Press and hold this key to immediately display the Default Navigation Page, regardless of which page is currently displayed.

The enter key (ENT) is used to approve an operation or complete data entry. It is also used to confirm information, such as during power on.

The large right knob is used to select between the various page groups: NAV, WPT, AUX or NRST. With the on-screen cursor enabled, the large right knob allows you to move the cursor about the page.

The small right knob (CRSR) is used to select between the various pages within one of the groups listed above. Press this knob momentarily to display the on-screen cursor. The cursor allows you to enter data and/or make a selection from a list of options.

BOTTOM ROW KEYS

The nearest (NRST) key displays the nearest airports page. Then, turning the small right knob steps through the NRST pages.

The OBS key is used to select manual or automatic sequencing of waypoints. Pressing the OBS key selects OBS mode, which will retain the current „active to“ waypoint as your navigation reference even after passing the waypoint (i.e., prevents sequencing to the next waypoint). Pressing the OBS key again will return to normal operation, with automatic sequencing of waypoints.

Whenever OBS mode is selected, you may set the desired course to/from a waypoint using the OBS Page, or an external OBS selector on your HSI or CDI.

The message key (MSG) is used to view system messages and important warnings and requirements.

The flight plan key (FPL) allows you to create, edit, activate and invert flight plans, as well as access approaches, departures and arrivals. A closest point to flight plan feature is also available from the flight plan key.

NOTE

Whenever the GNC 420W/GNS 430W is displaying a list of information that is too long for the display screen, a scroll bar will appear along the right-hand side of the display. The scroll bar graphically indicates the number of additional items available within the selected category. Simply press the small right knob to activate the cursor and turn the large right knob to scroll through the list.

The procedures key (PROC) allows you to select and remove approaches, departures and arrivals from your flight plan. When using a flight plan, available procedures for your departure and/or arrival airport are offered automatically. Otherwise, you may select the desired airport, then the desired procedure.

POWERING UP THE GNC 420W/GNS 430W

The GNC 420W/GNS 430W power and COM volume are controlled using the power/volume knob at the top left corner of the unit. Turning it clockwise will turn unit power on and increase the COM radio volume. After turning the unit on, a *welcome page* will be displayed while the unit performs a self test, followed by the database confirmation pages which show the current database information on the NavData card (with the valid operating dates, cycle number and database type indicated). The database is updated every 28 days, and must be current for instrument approach operations. Information on database subscriptions is available inside your GNC 420W/GNS 430W package.

To acknowledge the database information, press ENT.

916.7.2 DEFAULT NAV PAGE

During most flights, the *default NAV, map* and *NAVCOM pages* will be the primary pages used for navigation. The *default NAV page* displays a graphic course deviation indicator (CDI), the active leg of your flight plan (as defined by the current „from“ and „to“ waypoints), and six user-selectable data fields. The default settings for these fields are distance to waypoint (DIS), desired track (DTK), bearing to waypoint (BRG), ground speed (GS), ground track (TRK) and estimated time en route (ETE). The *default NAV page* is selected by pressing and holding the CLR key or turning the small right knob.

Left blank intentionally

SECTION 917
ASPEN EFD1000/500

Table of Contents

<i>Paragraph</i>		<i>Page</i>
917.1	GENERAL	917-3
917.1.1	Equipment Configuration	917-4
917.2	LIMITATIONS	917-4
917.2.1	Placards and Decals	917-4
917.3	EMERGENCY PROCEDURES	917-6
917.4	NORMAL PROCEDURES	917-6
917.5	PERFORMANCE	917-6
917.6	WEIGHT & CENTER OF GRAVITY	917-6
917.7	SYSTEM DESCRIPTION	917-6
917.7.1	General	917-6
917.7.2	Pitot Obstruction Monitor (Configuration 5 only)	917-6
917.7.3	Databases (EFD1000/500 MFD Only)	917-7
917.7.4	RSM GPS Usage	917-8
917.7.5	Operation on Internal Battery	917-8
917.7.6	Geographic Reservation	917-9
917.7.7	Hazard Awareness (EFD1000 PFD PRO and MFDs ONLY)	917-9
917.7.8	Evolution Synthetic Vision (Optional)	917-11
917.7.9	Aspen PFD as Encoded Altitude Source	917-12
917.8	HANDLING, SERVICING AND MAINTENANCE	917-12

Left blank intentionally

917.1 GENERAL

This Airplane Flight Manual Supplement (AFMS) applies to avionics installations of the following display combinations:

1. EFD1000 PFD Pilot
2. EFD1000 PFD Pilot and EFD500 MFD
3. EFD1000 PFD Pro
4. EFD1000 PFD Pro and EFD500 MFD
5. EFD1000 PFD Pro and EFD1000 MFD

The Evolution Flight Display System is a multi-display, highly capable Electronic Flight Instrument System (EFIS) with integral Micro Electromechanical Systems (MEMS)-based Air Data Attitude and Heading Reference System (ADAHRS) with an internal backup battery. The EFD 1000 PFD „Pilot“ offers a state-of-the-art Flight Display with attitude indication and slaved Directional Gyro with mapping. The EFD 1000 PFD „Pro“ offers a HSI/two pointer RMI instead of the Directional Gyro. When combined with the optional EFD 500 MFD the system offers a multi-panel, Multi-Function-Display solution that displays high resolution moving maps with Jeppesen© enroute and terminal data as well as relative terrain depictions. When combined with the optional EFD 1000 MFD an independent redundant ADAHRS source provides secondary attitude information and a secondary HSI display at the push of a button. The EFD1000 MFD can instantly revert to a fully-functional flight display generated from ADAHRS data completely independent of that generated by the PFD.

The EFD1000 Pilot PFD is a Flight Display with Attitude indicator, heading indicator and moving map. The Pilot PFD cannot be installed with an EFD1000MFD.

The EFD500 is a fully functional MFD with all the capability of the EFD1000 MFD except reversion, HSI, Remote Sensor Module (RSM), Cross Link information (receive only) and the air data, attitude and heading features.

The standard internal battery in the EFD1000 or EFD500 is capable of providing 30 or more minutes of operation at typical cockpit temperatures if aircraft power to the system fails. An Emergency Backup Battery is not installed.

In the EXTRA 300LT the EFD1000/500 system is used as a secondary (back-up) instrument system.



CAUTION

Due to the capabilities of the aircraft - especially the extreme agility with high angular rates - the EFD1000/500 System cannot be operated reliably in acrobatics. Observe flags and reset EFD1000/500 System if required.

NOTE

Due to the location of the Remote Sensor Module (RSM) the outside air temperature data are available time-delayed.

The EFD1000/500 System must utilize the software version described below or later approved versions. The system software version for the Main Application Processor (MAP) and for the Input-Output Processor (IOP), both of which are contained within the EFD display head, is displayed via the Main Menu SYSTEM STATUS page.

This supplement is written for MAP SOFTWARE RELEASE 2.4.1 and IOP SOFTWARE RELEASE 2.0.2 and is not suitable for earlier software versions. Some differences in operation may be observed when comparing the information in this supplement to later software versions. Verify the information herein depending on the configuration installed with the EFD1000 PFD and/or EFD1000/500 MFD Pilot's Guide(s) (Doc. 091-00005-001(A) and/or 091-00006-001(-)) and/or the Evolution Synthetic Vision Pilot's Guide Supplement (Doc. 091-00032-001(B)) you received with your unit(s). Additional information can be found in these documents as well.

917.1.1 EQUIPMENT CONFIGURATION

The table below shows the various possible configurations of Aspen equipment for the 300LT. Refer to the Equipment List in Section 6 to verify, which configuration is actually installed in your aircraft.

Figure 1 provides a block diagram of a complete EFD1000/500 System installation.

Configuration	PFD Pilot	PFD Pro	500 MFD	1000 MFD	RSM GPS	RSM
1	X				X	
2	X		X		X	
3		X			X	
4		X	X		X	
5		X		X	X	X

917.2 LIMITATIONS

This supplement does not grant approval for IFR operations.

The Aspen flight displays have been installed on a no hazard, no credit basis. Therefore the information provided by these instruments shall not be relied upon for operation of the aircraft as well as for navigational purposes.

The navigation data incl. for final approach segments provided by the Aspen PFD/MFD is for situational awareness only and should not be relied upon for navigation.

The aircraft ownship position presented on the Airport Diagrams may be inaccurate - reference to the ownship position for navigation or maneuvering is prohibited.

917.2.1 PLACARDS AND DECALS

- PFD** (Next to the EFD PFD System circuit breaker)
- MFD** (Next to the EFD MFD System circuit breaker)
- For situational awareness only** (above the EFD display head(s))

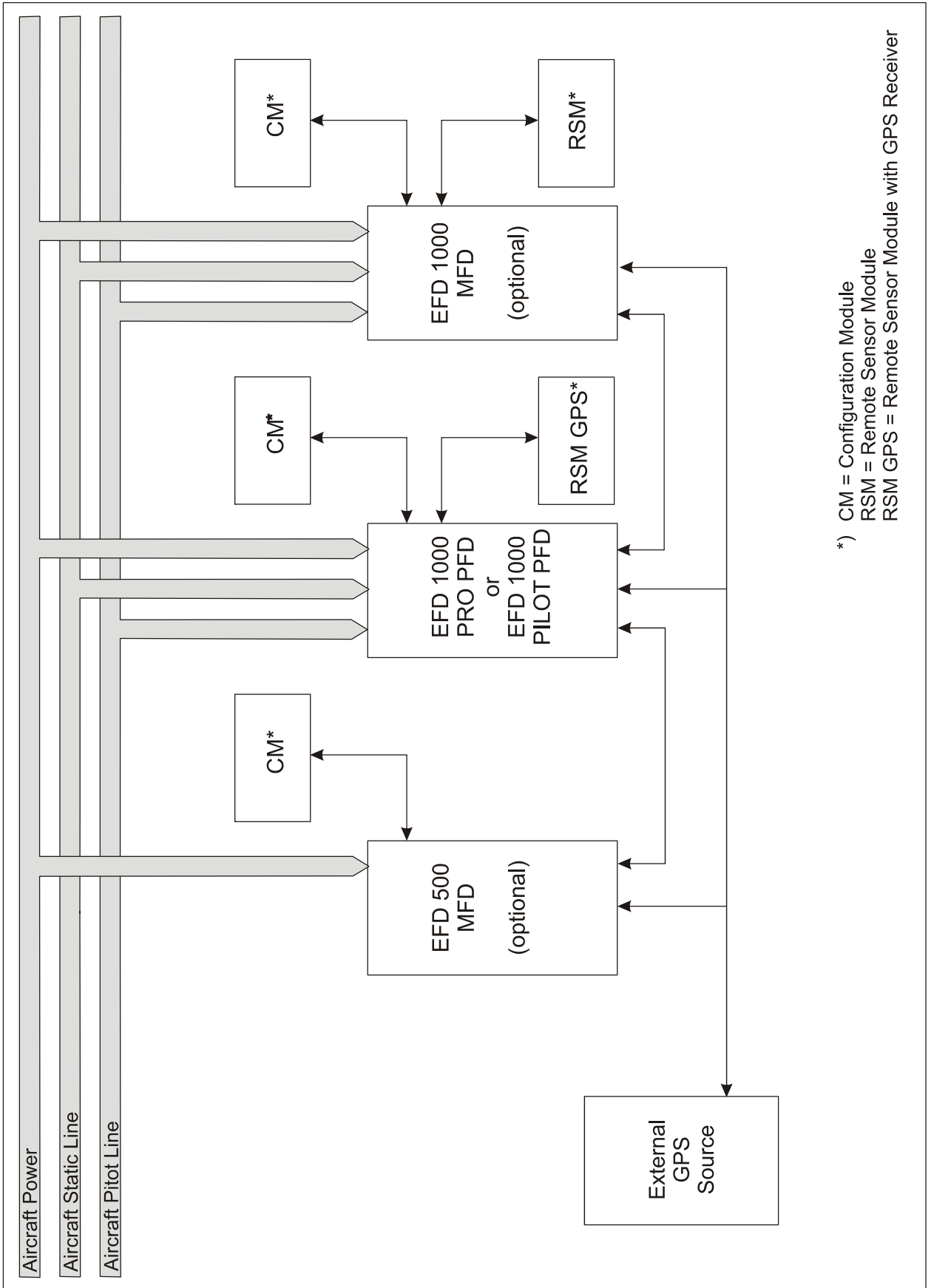

Figure 1, Equipment Configuration

917.3 EMERGENCY PROCEDURES

Not affected due to the use as a secondary instrument.

917.4 NORMAL PROCEDURES

Not affected due to the use as a secondary instrument.

917.5 PERFORMANCE

Not affected.

917.6 WEIGHT & CENTER OF GRAVITY

Refer to the Equipment List in Section 6 of this Handbook.

917.7 SYSTEM DESCRIPTION

917.7.1 GENERAL

Refer to the Aspen Pilot's Guide(s) as specified in paragraph 917.1 for description of the EFD1000/500 System.

917.7.2 PITOT OBSTRUCTION MONITOR (CONFIGURATION 5 ONLY)

The Pitot Obstruction Monitor is available only in configuration 5 (EFD1000 PFD Pro and EFD1000 MFD).

A common pitot and static input is shared between the EFD1000 PFD, the EFD1000 MFD and the primary airspeed indicator. Should one or both of these lines become blocked, such as might occur due to an inadvertent icing encounter or from water trapped in the lines, then both the EFD1000 PFD and the EFD1000 MFD, along with the primary indicators of airspeed and altitude, could display erroneous airspeed and altitude information.

Furthermore, because the EFD1000 uses pitot and static pressures as part of the ADAHRS attitude solution, loss or corruption of the pitot or static pressures could also influence the accuracy of attitude information.

The EFD1000 has been shown to be robust to these failures, either by being tolerant to incorrect pitot or static inputs, or by detecting and annunciating a degraded attitude solution. In combination with the installed GPS the system evaluates indicated airspeed and GPS groundspeed to identify conditions indicative of a blockage in the pitot system. If a blockage is detected the monitor will fail the attitude solution, post a red X in place of the attitude and heading information, and present

a „CHECK PITOT HEAT“ message as a reminder to the pilot to check for ice accumulating on the pitot probe. An „ATTITUDE FAIL“ annunciation will accompany the „CHECK PITOT HEAT“ amber annunciation, and will be presented when indicated airspeed is less than 30 KIAS (35 mph) and GPS groundspeed is greater than 50 kts (58 mph).

NOTE

The EXTRA 330LX doesn't feature a pitot heating system. So the „CHECK PITOT HEAT“ amber annunciation shall be taken as a note, that a failure of the pitot/static system has been detected.

In this case the following actions shall be performed:

1. Select the alternate static source (if installed).
2. Cross-check the readings of the primary airspeed indicator, the airspeed indications of the two EFD1000 displays and the GPS generated groundspeed indication, to find out which values are corrupt. In case of doubt use the visual horizon as a liable reference.

Once the system detects that the pitot obstruction has been cleared, the „CHECK PITOT HEAT“ annunciation is removed and the system automatically performs an ADAHRS in-flight reset.

Should a GPS failure be experienced in flight, the Pitot Obstruction Monitor continues to operate in a fail safe mode and will continue to detect obstructions in the pitot system that might occur. However, post landing the monitor remains active and as the airplane slows below 30 KIAS the system will post a red X in place of the attitude and heading information and post the „CHECK PITOT HEAT“ message. In this circumstance, restoring the GPS system, or cycling power to the affected EFD1000, will restore normal monitor operation.

In some (acrobatic) maneuvers it may be possible to activate the Pitot Obstruction Monitor for example at indicated airspeeds below 30 KIAS. Under these circumstances if the groundspeed exceeds 50kts the monitor will activate.

To restore normal ADAHRS operation, increase the indicated airspeed to a value greater than 30 KIAS; the affected display will then perform an automatic reset.

917.7.3 DATABASES (EFD1000/500 MFD ONLY)

NOTE

To operate the EFD1000 MFD and EFD500 MFD the database currency date must be acknowledged prior to each flight. Flight with an expired database is not recommended. An expired database does not prevent terrain or other Nav Map features from being displayed on the MFD.

Each EFD1000/500 MFD uses several databases. The EFD1000 PFD does not require a database. The Jeppesen NavData©, Cultural database and Obstacle database are all combined into a single download from Jeppesen. Terrain data is loaded at the factory and does not require periodic updating. Data base valid dates are displayed at power up and require a pilot action to acknowledge. Database information can also be accessed via the main menu.

Database Type	Includes	Update Cycle	Database Provider	Limitations
	High resolution terrain data for Americas, International, or Worldwide geographic regions. Terrain depiction is limited to the region between 65 deg N orth latitude to 65 deg South latitude	Delivered with unit, updated as desired	Jeppesen mail order	These databases are intended to improve flight crew awareness and are not to be used for navigation
NavData	Includes Navaids, Controlled Airspace, Restricted, Prohibited and Special Use Airspace, Airports, etc.	28 day update cycle	Jeppesen JSUM	
Cultural	Includes Roads, Rivers, Railroads, Political boundaries, Cities, etc.	28 day update cycle	Jeppesen JSUM	
Obstacles	Includes man made obstacles greater than 200 ft. AGL. This database relies upon data reported by government agencies and may not include all obstacles due to inherent reporting and processing delays in the data. In addition, obstacle data may not be available for all regions within the data card coverage area.	28 day update cycle	Jeppesen JSUM	
Charts	NACO Terminal Procedures Charts	28 day update cycle	Seattle Avionics	

917.7.4 RSM GPS USAGE

The EFD1000/500 System includes a non-certified GPS receiver. This GPS can provide positioning data when all other approved sources of GPS data have failed.

Position data from the RSM GPS will only become available for use following a loss of position information from all other connected GPS system(s). When the RSM GPS is in use, the current flight plan leg will be shown in white rather than magenta, and a message is presented limiting the RSM GPS to EMERGENCY USE ONLY.

917.7.5 OPERATION ON INTERNAL BATTERY

NOTE

Takeoff with aircraft voltage (as indicated on the EFD) below 12.3V is not recommended.

Each EFD1000 or EFD500 is equipped with an internal battery.

The EFD System incorporates sophisticated power logic to determine when to transition to the internal battery. On the ground, the system will turn on and turn off with the application or removal of aircraft power. In the air, the system will transition to battery if aircraft power is removed or degraded. Transition thresholds and times will vary as a function of the input voltage to the display, which can be observed via the Menu Power Settings Page.

Battery operation should be expected any time the aircraft charging system is unable to maintain a voltage at the EFD of 12.3 V. Under these circumstances, should the aircraft dispatch the EFD will transition to battery shortly after reaching flying speed.

917.7.6 GEOGRAPHIC RESERVATION

NOTE

Use of the EFD1000 in the region within 750 nautical miles of the magnetic North or South Pole, based solely upon the attitude and heading data provided by the EFD1000, is not recommended.

The ADAHRS solution in the EFD1000 uses multiple inputs, including the earth's magnetic field, to determine aircraft heading, pitch and roll. The system must be able to periodically sense the earth's magnetic vector to be able to correctly resolve heading and stabilize the ADAHRS attitude solution.

All magnetic sensors, including the one in the EFD1000, will experience degraded performance in the vicinity of the earth's magnetic poles. When the horizontal component of the earth's magnetic field is no longer strong enough to provide reliable heading data, the EFD1000 will detect this condition and compensate for the reduced magnetic fields. The system can continue to operate for a short time without reference to magnetic North, but must be able to periodically resolve the magnetic vector to continue operations.

If the EFD1000 is unable to resolve the earth's magnetic field for two minutes, the system will switch to and annunciate Free Gyro Mode. In this mode, the ADAHRS continues to provide attitude and heading data based on gyro-only operating logic. This will be accompanied by a „FREE GYRO MODE“ message posted on the HSI, and a „CROSS CHECK ATTITUDE“ annunciation posted on the attitude indicator. Under these circumstances, increased vigilance and instrument cross check is required.

If the weak magnetic conditions persist, and the EFD1000 is unable to resolve the magnetic vector for six minutes or greater, then the attitude and heading solution will be considered failed and will be removed (i.e. Red X'd). The ADAHRS solution will automatically restore once the magnetic vector can again be resolved.

Within a region approximately 750 nautical miles from the magnetic pole, the conditions described above are expected to be persistent.

917.7.7 HAZARD AWARENESS (EFD1000 PFD PRO AND MFDS ONLY)

NOTE

Maneuvering based solely on the EFD1000 terrain and obstacle display is extremely dangerous and prohibited. Pilot in command has the responsibility to see and avoid terrain and other obstacles.

The EFD1000/500 MFD display of terrain and obstacle information is advisory only. In addition, the system does not provide terrain or obstacle alerts. Not all obstacles within a given region will be charted. The pilot is responsible for terrain and obstacle avoidance by visual means.

NOTE

Maneuvering based solely on the EFD1000 traffic display is not authorized. The pilot in command has the responsibility to see and avoid traffic.

The EFD1000/500 MFD and EFD1000 PFD will display traffic when connected to a TIS source (e.g. Garmin GTX 33 or GTX 330). The TIS information is only available in the US. Traffic information is presented to assist the pilot in visually identifying nearby aircraft.

NOTE

The EFD1000/500 moving map display is not a substitute for approved maps or charts required by the operating rules. Approved maps and charts must be carried in the aircraft, as required by the applicable operating regulations.

NOTE

The aircraft ownship position presented on the Airport Diagrams may be inaccurate - reference to the ownship position for navigation or maneuvering is prohibited.

The intended function of Aerodrome Moving Map Display (AMMD) is to help flight crew orient themselves on the airport surface and improve pilot positional awareness during taxi operations. AMMD function is not sufficient to be used as the basis for maneuvering and shall not be used for navigation. This application is limited to ground operations only.

The intersection of the wings and fuselage of the aircraft ownship symbol on the AMMD corresponds to the ownship's actual position.

NOTE

The Terminal Procedures Charts depictions on the EFD are not substitutes for aeronautical charts required to be carried aboard the aircraft. This function does not replace any system or equipment required by the regulations. The aircraft ownship position presented on the Terminal Procedures Charts may be inaccurately portrayed due to errors in the charts - reference to the ownship position for navigation or maneuvering is prohibited.

The intended function of the Terminal Procedures Charts depiction without the aircraft ownship depicted on the chart is to provide a convenient location to view portions of the Terminal Procedures Charts information.

The Terminal Procedures Charts depiction is not sufficient to be used as the basis for maneuvering and must not be used for navigation.

917.7.8 EVOLUTION SYNTHETIC VISION (OPTIONAL)

NOTE

Navigation or maneuvering based solely on the EFD1000 or MFD500 Synthetic Vision background display and associated Terrain Warning System (TWS) is not authorized. The Pilot in command has the responsibility to use accepted visual procedures to avoid terrain and other obstacles.

NOTE

Flight with an expired database is not recommended. An expired database does not prevent terrain or other Synthetic Vision features from being displayed.

NOTE

No Sonalert installed. Only on-screen Alert Annunciations, FPM Alert Colors, and Terrain Coloring are configured

The EFD1000/500 Evolution Synthetic Vision system provides a computer-derived view of the nearby terrain, obstacles and airports. The Flight Path Marker graphically presents the aircraft vertical speed and the GPS track converted to an angular direction. The Terrain Warning System (TWS) uses the Flight Path Marker to present an estimated time-to-collision function for terrain and obstacles combined with a terrain proximity view that colorizes nearby terrain based on the relative aircraft height. Unless inhibited by the pilot, TWS even operates when SV is turned off.

The EFD100/500 display of Synthetic Vision information is advisory only. The pilot is responsible for terrain and obstacle avoidance by visual means. At system start up the pilot must acknowledge this operational limitation by pressing either MODE/SYNC knob.

Evolution Synthetic Vision is a computer-generated image of the external scene topography from the perspective of the flight deck, derived from aircraft altitude, high-precision navigation solution, and database of terrain, obstacles and cultural features, such as runways. Evolution Synthetic Vision creates an image relative to terrain, obstacles and airports within the limits of the navigation source, altimetry and databases. Evolution Synthetic Vision provides situation awareness, but no operational credit. The intended function is flight crew awareness of the external scene topography.

The Aspen Evolution Synthetic Vision System uses 9 arc-second resolution data enhanced with 3 arcsecond data to provide better depiction of the terrain. The depiction of terrain is most like the outside view in the narrow FOV1 view, and a more expansive view of the horizon is available in FOV2. The terrain depicted in FOV2 is closer than it appears.

The intended function of the Flight Path Marker is to display the current vertical and lateral path of the aircraft based on two parameters, barometric vertical speed and GPS track. These parameters lag during dynamic maneuvers. Therefore the Flight Path Marker should only be used during steady state, nonaccelerated flight. It is not intended to provide accurate information during turns, transitions to climb or descent or acrobatics.

The intended function of the Terrain Warning System associated with the Evolution Synthetic Vision application is to provide warnings when the system predicts a collision with the terrain or an obstacle. The Flight Path Marker is an integral part of this system and changes in shape and color

if the aircraft continues on the collision path. In addition, the terrain is colored based on the aircraft proximity to the terrain; yellow when the aircraft is within 500 feet vertically of the terrain or obstacle, and red when the aircraft is within 100 feet vertically.

NOTE

Synthetic Vision and the associated Terrain Warning System are dependant on accurate barometric altitude. An inaccurate altimeter setting will cause an incorrect depiction of the elevation of terrain and obstacles. Very cold temperatures can also cause significant errors in alimetry. The pilot in command has the responsibility to use accepted visual procedures to avoid terrain and obstacles.

Obstacles less than 200 feet AGL are not displayed. Terrain and obstacle information is intended to assist the flight crew in fulfilling the responsibility to avoid terrain and obstructions through visual means.

Pressing menu and selecting "TWS INH" will inhibit the Terrain Warning System. An annunciator will indicate that TWS is inhibited. TWS can be inhibited for all applications except Synthetic Vision by selecting "SV ONLY". When TWS is inhibited, no terrain warning is provided.

Terrain/obstacle caution and warning messages are generated due to nearby terrain or obstacles. On a non-precision approach a terrain caution or warning is probable depending on the rate of descent toward the terrain. Landings at most airports do not generate an alert. Some airports with unusual topography may generate alerts when the flight path marker points toward nearby higher terrain.

917.7.9 ASPEN PFD AS ENCODED ALTITUDE SOURCE

The EFD1000 PFD can provide encoded altitude informatio to connected units. Do not unpower the Aspen PFD when using the Garmin GTN 635/650/750 or the GTX 33 remote transponder.

917.8 HANDLING, SERVICING AND MAINTENANCE

If the temperature sensor of the RSM is suspected to fail, it is advisable to initiate a check of the RSM vent hole. Consider that it is necessary to remove the aircraft tail fairing for that purpose.

Replace the EFD internal battery every 3 years or 2200 hours.

Check unit and wiring every 100 hours or during annual inspection.

Refer to Aspen Document # 900-00012-001 latest revision for Instructions for Continued Airworthiness.

SECTION 918

EI MVP-50P

Table of Contents

<i>Paragraph</i>		<i>Page</i>
918.1	GENERAL	918-3
918.2	LIMITATIONS	918-3
918.2.1	Instrument Markings	918-3
918.3	EMERGENCY PROCEDURES	918-4
918.4	NORMAL PROCEDURES	918-4
918.5	PERFORMANCE	918-4
918.6	WEIGHT & CENTER OF GRAVITY	918-5
918.7	SYSTEM DESCRIPTION	918-5
918.7.1	Instrument Panel Layout	918-6
918.8	HANDLING, SERVICING AND MAINTENANCE	918-7

Left blank intentionally

918.1 GENERAL

The MVP-50P is a Glass Panel Engine Monitor that provides both analog and digital displays with digits that blink and change colors when yellow or red operating ranges are reached. All of these features are designed to alert the pilot the moment any monitored function exceeds its normal operating limit.

The following features are not available in the configuration installed in the EXTRA 330LX:

- External dimmer potentiometer
- External warning and caution light
- Voice alarm
- System Screen
- Weight and Balance (not applicable, do not use!)
- Checklists 1 - 3 (not applicable, do not use!)
- Gear warning and TAS Setup Screen
- Pressure Altitude Calibration Screen
- Flaps, Trim and Special Function Calibration Screen
- Calibrating Airspeed
- Gear Position and Unsafe Indicators
- Gear Warning

An additional fuel contents transmitter is installed in the RH wing, when the MVP-50P is used.

This supplement is written for Software Version 2.7 and is not suitable for earlier software versions. This software version corresponds to the MVP-50P Operating Instructions (Doc. OI 1002051 Revision D: 4/25/08). Some differences in operation may be observed when comparing the information in this supplement to later software versions. Verify the information herein with the MVP-50P Operating Instructions you received with your unit. There you will also find further information.

There are two different configurations available:

- MVP-50P-EX-03 max 2600 RPM for Normal Category
- MVP-50P-EX-04 max 2700 RPM for Acro Category

918.2 LIMITATIONS

918.2.1 INSTRUMENT MARKINGS

The following markings deviate from the values given in Section 2 of this Handbook:

RPM INDICATOR (for configuration MVP-50P-EX-03)

green range	2000 rpm - 2600 rpm
red line	2600 rpm

RPM INDICATOR (for configuration MVP-50P-EX-04)

green range	2000 rpm - 2700 rpm
red line	2700 rpm

FUEL PRESSURE INDICATOR

green range	0 psig - 14 psig
red line	14 psig

918.3 EMERGENCY PROCEDURES

Not affected.

918.4 NORMAL PROCEDURES

Magneto Check

- Check the magnetos at 1800 RPM. Allowed drop is 175 RPM (max. difference 50 RPM).
- Check Alternator Output.
- Move also the propeller control through its complete range to check operation and return to full "HIGH RPM" position.
Turn boost pump "ON" (check indicator movement on the fuel flow gauge).

During engine start:

MVP-50P

ON

918.5 PERFORMANCE

Not affected.

918.6 WEIGHT & CENTER OF GRAVITY

Refer to the equipment list in Section 6 of this Handbook.

918.7 SYSTEM DESCRIPTION

The MVP-50P Main Engine Screen displays the primary engine and aircraft instruments. This screen is displayed on power-up and is the screen that should be monitored for most of the flight.



Figure 1, MVP-50 with Main Engine Screen

Buttons operate as follows:

Push-Select Moves the cursor, selects functions and changes digits.

Exit Exits out of a field or screen and returns the display to the Main Engine Screen.

Screens Switches the display between screens as selected in the Screens Button Setup.

Menu Displays a menu (if available) for the current screen.

To assist the pilot in identifying the current operating band (green, yellow, red, etc.), the MVP-50P displays the digital value for each function in its appropriate color band. When a function reaches a red or yellow operating band, blinking digits for that function will alert the pilot. To acknowledge the alarm and stop the blinking on the MVP-50P display, press any button while viewing the Main Engine Screen. To determine the current operating band for a function, refer to the pointer position in the color band or the color of the digits.

NOTE

Any instrument can fail at any time. Acquire proper training to safely operate this aircraft without the use of this instrument. Refer to the Operating Instructions for further operating and safety information.

918.7.1 INSTRUMENT PANNELAYOUT

Generally an alternate panel is used to carry the MVP-50. For that reason the circuit breaker layout also changes as shown in Figure 2.

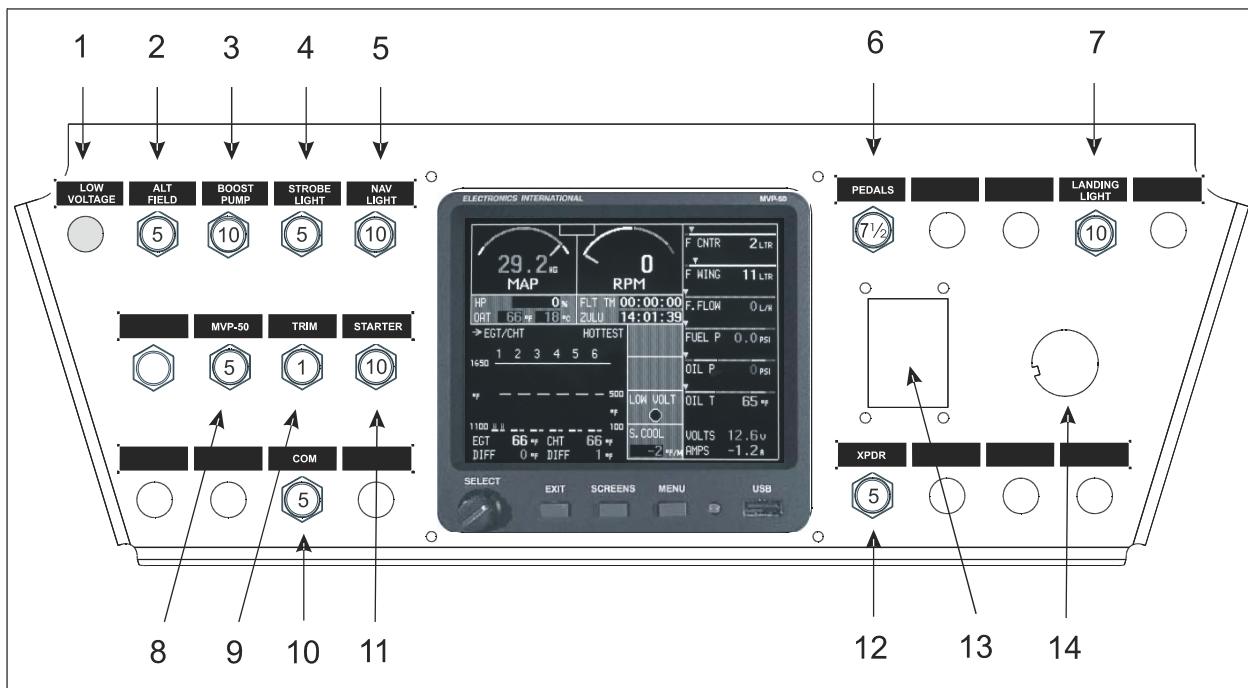

Figure 2, Alternate Panel Layout

Position Fig. 2	Item
1	Alternator warning light incl. press-to-test feature (located in the switch-row, if sub panel is not used)
2	Alternator field circuit breaker
3	Boost pump circuit breaker
4	Strobe light circuit breaker
5	NAV light circuit breaker
6	Electrical pedal adjustment circuit breaker
7	Landing light circuit breaker
8	MVP-50 circuit breaker
9	Electrical trim system circuit breaker
10	COM circuit breaker
11	Starter circuit breaker
12	Transponder circuit breaker
13	ELT Switch
14	Starter switch

918.8 HANDLING, SERVICING AND MAINTENANCE

The Level #1 password (for maintenance) is 00200.

The Level #2 Password (for system configuration) is published only by the aircraft manufacturer.

Left blank intentionally

**SECTION 919
LANDING LIGHT**

Table of Contents

<i>Paragraph</i>		<i>Page</i>
919.1	GENERAL	919-3
919.2	LIMITATION	919-3
919.3	EMERGENCY PROCEDURES	919-3
919.4	NORMAL PROCEDURES	919-3
919.5	PERFORMANCE	919-3
919.6	WEIGHT AND BALANCE	919-3
919.7	DESCRIPTION OF THE SYSTEM	919-3
919.8	HANDLING, SERVICING AND MAINTENANCE	919-4

Left blank intentionally

919 LANDING LIGHT

919.1 GENERAL

To improve the visibility of the aircraft during landing approach a landing light can be integrated in the RH lower cowling.

919.2 LIMITATION

No change.

919.3 EMERGENCY PROCEDURES

No change.

919.4 NORMAL PROCEDURES

No change.

919.5 PERFORMANCE

No change.

919.6 WEIGHT AND BALANCE

Refer to the Equipment List in section 6 of this Handbook.

919.7 DESCRIPTION OF THE SYSTEM

The landing light is controlled by the LANDING LIGHT switch on the right instrument panel. The system is protected by the LANDING LIGHT circuit breaker.

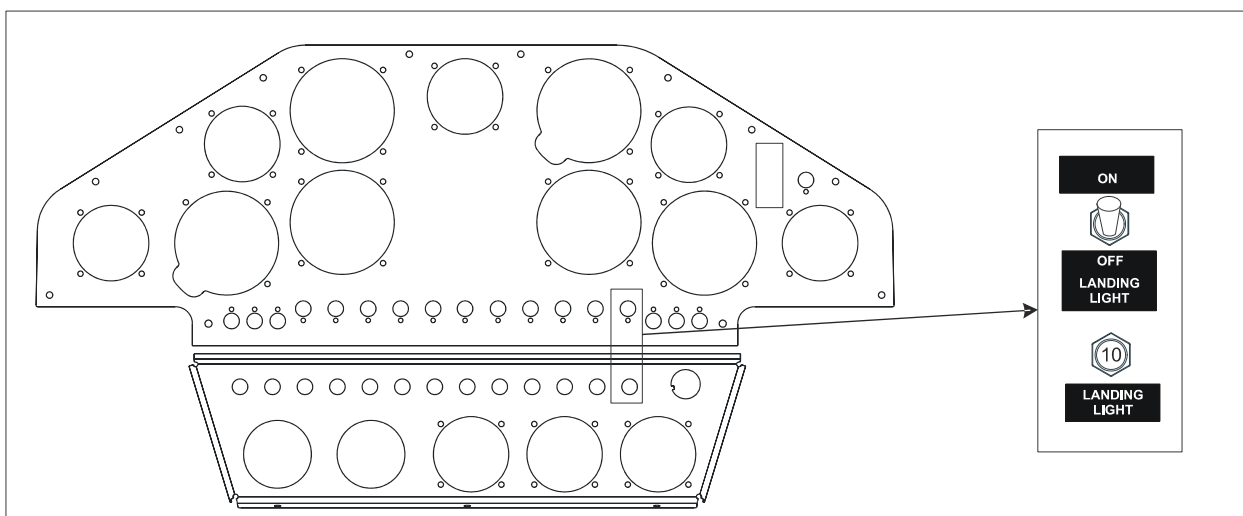

919.8 HANDLING, SERVICING AND MAINTENANCE

No change.

SECTION 920

AIRTOW HOOK

Table of Contents

<i>Paragraph</i>		<i>Page</i>
920.1	GENERAL	920-3
920.2	LIMITATIONS	920-3
920.3	EMERGENCY PROCEDURES	920-4
920.4	NORMAL PROCEDURES	920-4
920.5	PERFORMANCE	920-5
920.6	WEIGHT AND BALANCE	920-7
920.7	DESCRIPTION OF THE SYSTEM	920-7
920.8	HANDLING, SERVICING AND MAINTENANCE	920-7

Left blank intentionally

920.1 GENERAL

The EXTRA 330LX can optionally be equipped with a "TOST" glider air-tow release Typ E 85. The release mechanism is mounted at the tail spring end and actuated from the cockpit by a yellow knob.

920.2 LIMITATIONS

The following combinations are certified:

Aircraft

- Engine: AEIO-580-B1A
- Propeller: MTV-9-B-C/C 198-25 or MTV-14-B-C/C190-130
- Exhaust system: Typ Gomolzig EA 300-606000
- Air-tow release system according to replacement instruction: UA-300-4-95
- Air-tow release: "TOST, E 85"

Glider

- MTOW of the glider: 765Kg (1687 lbs)
- Max. air towing speed of the glider: 152 km/h or above

Air tow cable and breaking piece (weak links)

- Length of the synthetic tow between 40 m (130 ft) and 60 m (195 ft)
- Ultimate load of the air-tow max. 850 kp (1875 lbs)
- If tows with higher ultimate load are used a breaking piece (weak links) of max. 850 kp (1875 lbs) must be interconnected.

For a safe air towing the following points must be observed:

	1-seat	2-seats *
Max. Takeoff Weight	820 kg (1813 lbs)	870 kg (1924 lbs)
Max. Empty Weight	701 kg (1546 lbs)	665 kg (1466 lbs)
Min. Air-Towing Speed	69 KIAS (128 km/h)	72 KIAS (133 km/h)
Best Air-Towing Speed	76-80 KIAS (141 - 148 km/h)	78-82 KIAS (144 - 152 km/h)

NOTE *

2-seats only in case of an instruction flight!

- 1.) Maximum air-towing speed = maximum permissible air-towing speed of the glider.
- 2.) The maximum permissible cylinder head temperature is 465° F (red line).
- 3.) Interior mirror mounted.

For the location of the yellow release knob the following placard has to be attached in the near of the knob:

AIR TOW

920.3 EMERGENCY PROCEDURES

A) ABORTED TAKE OFF

- | | |
|------------------------|--------------------|
| 1. Pilot of the glider | INFORM |
| 2. Throttle | IDLE |
| 3. Mixture | IDLE CUT OFF |
| 4. Brakes | APPLY AS PRACTICAL |

B) ENGINE FAILURE IMMEDIATELY AFTER TAKEOFF

Stall speed: 64 KIAS (119 km/h)

- | | |
|------------------------|----------------------|
| 1. Pilot of the glider | INFORM |
| 2. Air tow | RELEASE |
| 3. Airspeed | 90 KIAS (167 km/h) |
| 4. Mixture | IDLE CUT OFF |
| 5. Fuel shutoff valve | OFF |
| 6. Ignition switch | OFF |
| 7. Master switch | OFF |
| 8. Forced landing | PERFORM AS PRACTICAL |

C) EXCESSIVE "CLIMB OVER" BY THE TOWING GLIDER

- | | |
|------------------------|----------------------|
| 1. Pilot of the glider | INFORM |
| 2. Air tow | RELEASE |
| 3. Landing | PERFORM AS PRACTICAL |

D) TOW BREAK

- | | |
|------------------------|----------------------|
| 1. Pilot of the glider | INFORM |
| 2. Landing | PERFORM AS PRACTICAL |

920.4 NORMAL PROCEDURES

Preflight inspection, starting procedures, take-off procedure and the following climbing flight have to be carry out in accordance with Chapter 4 "Normal procedure". In addition to this procedures the following points have to be observed:

A) PRIOR TO THE TAKE OFF

A release test needs to be conducted to determine safe release operation. The test shall be made on both, aircraft and glider.

B) TAKE OFF

After air-tow hook up the tow shall be tightened gently. During the following take-off and climb the maximum air-tow speed of the glider must be observed.

C) CLIMB

While climbing the max C.H.T. must be observed. Towing light gliders, the intial climb angle may be very steep. Information of the glider pilot is recomended.

D) RELEASE

After the release of the glider a gently left handed descent shall be flown to avoid collision of glider and air-tow.

E) DESCENT AND LANDING

While descending the engine temperatures shall be observed (avoid overcooling). Final approach should account for the air-tow hanging below the aircraft flight path.

920.5 PERFORMANCE

The existing POH-Data remain valid with the exception of:

TAKE-OFF DISTANCE

Conditions:

Power: 2600 Rpm and full throttle, mixture rich,
short grass, dry and paved level runway, no wind,
takeoff weight of the towing aircraft: 820Kg (1808lbs)

Liftoff speed (T/O): 68 KIAS = 126 Km/h indicated

Obstacle clearance speed over 15m (50ft) : 74 KIAS = 137 Km/h indicated

For every 5 kts (9 km/h) headwind, the takeoff (T/O) distance can be decreased by 5%. For every 2 kts (4 km/h) tailwind [up to 10 kts (19 km/h)], the (T/O) distance is increased by 10%.

CAUTION

All values are valid for **single-pilot** air-towing operation [820kg (1808 lbs) TOW]. In case of an instruction flight with copilot, the higher takeoff weight has to be considered!
The maximum permissible air-towing speed of the glider needs to be observed!

TAKE-OFF DISTANCE

Takeoff weight glider: 350 kg (772 lbs)

	OAT -10°C(14°F)		0°C(32°F)		10°C(50°F)		20°C(68°F)		30°C(86°F)		40°C(104°F)	
	T/O roll m(ft)	15 m (50 ft) m(ft)	T/O roll m(ft)	15 m (50 ft) m(ft)	T/O roll m(ft)	15 m (50 ft) m(ft)	T/O roll m(ft)	15 m (50 ft) m(ft)	T/O roll m(ft)	15 m (50 ft) m(ft)	T/O roll m(ft)	15 m (50 ft) m(ft)
PA ft(m)	134 (440)	219 (719)	150 (492)	244 (801)	166 (545)	271 (889)	184 (604)	300 (984)	202 (663)	331 (1086)	223 (732)	364 (1194)
SL	156 (512)	256 (840)	174 (571)	285 (935)	194 (636)	316 (1037)	214 (702)	350 (1148)	236 (774)	386 (1266)	260 (853)	424 (1391)
2000 (610)	183 (600)	299 (981)	204 (669)	333 (1093)	226 (741)	370 (1214)	251 (823)	409 (1342)	276 (906)	451 (1480)	304 (997)	497 (1631)
4000 (1219)	214 (702)	350 (1148)	239 (784)	390 (1280)	265 (869)	434 (1424)	294 (965)	480 (1575)	324 (1063)	530 (1739)	357 (1171)	583 (1913)
6000 (1829)	252 (827)	411 (1348)	281 (922)	459 (1506)	312 (1024)	510 (1673)	346 (1135)	565 (1854)	382 (1253)	624 (2047)	421 (1381)	687 (2254)
8000 (2438)												

Takeoff weight glider: 600 kg (1323 lbs)

	OAT -10°C(14°F)		0°C(32°F)		10°C(50°F)		20°C(68°F)		30°C(86°F)		40°C(104°F)	
	T/O roll m(ft)	15 m (50 ft) m(ft)	T/O roll m(ft)	15 m (50 ft) m(ft)	T/O roll m(ft)	15 m (50 ft) m(ft)	T/O roll m(ft)	15 m (50 ft) m(ft)	T/O roll m(ft)	15 m (50 ft) m(ft)	T/O roll m(ft)	15 m (50 ft) m(ft)
PA ft(m)	176 (577)	287 (942)	196 (643)	320 (1050)	217 (712)	355 (1165)	240 (787)	393 (1289)	265 (869)	433 (1421)	291 (955)	476 (1562)
SL	205 (673)	334 (1096)	228 (748)	373 (1224)	253 (830)	414 (1358)	280 (919)	458 (1503)	309 (1014)	505 (1657)	340 (1115)	555 (1821)
2000 (610)	239 (784)	391 (1283)	267 (876)	436 (1430)	296 (971)	484 (1588)	328 (1076)	535 (1755)	362 (1188)	591 (1939)	398 (1306)	650 (2133)
4000 (1219)	280 (919)	458 (1503)	313 (1027)	511 (1677)	347 (1138)	567 (1860)	385 (1263)	628 (2060)	425 (1394)	693 (2274)	467 (1532)	763 (2503)
6000 (1829)	329 (1079)	538 (1765)	368 (1207)	600 (1969)	409 (1342)	668 (2192)	453 (1486)	740 (2428)	500 (1640)	817 (2680)	550 (1804)	899 (2949)
8000 (2438)												

Takeoff weight glider: 765 kg (1687 lbs)

	OAT -10°C(14°F)		0°C(32°F)		10°C(50°F)		20°C(68°F)		30°C(86°F)		40°C(104°F)	
	T/O roll m(ft)	15 m (50 ft) m(ft)	T/O roll m(ft)	15 m (50 ft) m(ft)	T/O roll m(ft)	15 m (50 ft) m(ft)	T/O roll m(ft)	15 m (50 ft) m(ft)	T/O roll m(ft)	15 m (50 ft) m(ft)	T/O roll m(ft)	15 m (50 ft) m(ft)
PA ft(m)	220 (722)	360 (1181)	245 (804)	401 (1316)	272 (892)	445 (1460)	301 (988)	492 (1614)	332 (1089)	542 (1778)	365 (1198)	596 (1955)
SL	257 (843)	419 (1375)	286 (938)	467 (1532)	317 (1040)	518 (1699)	351 (1152)	574 (1883)	387 (1270)	633 (2077)	426 (1398)	696 (2283)
2000 (610)	300 (984)	489 (1604)	334 (1096)	546 (1791)	371 (1217)	606 (1998)	411 (1348)	671 (2201)	453 (1486)	740 (2428)	499 (1637)	814 (2671)
4000 (1219)	351 (1152)	574 (1883)	392 (1286)	640 (2100)	435 (1427)	711 (2333)	482 (1581)	787 (2582)	532 (1745)	869 (2851)	585 (1919)	956 (3136)
6000 (1829)	413 (1355)	674 (2211)	461 (1512)	752 (2467)	512 (1680)	836 (2743)	567 (1860)	926 (3038)	626 (2054)	1023 (3356)	690 (2264)	1126 (3694)
8000 (2438)												

CLIMBRATE

Conditions:

Power: 2500 Rpm and full throttle, mixture rich,
Speed of the aircraft tow: 80 KIAS = 148 Km/h,
Weight of the towing aircraft: m = 820 Kg (1808 lb)

Tow force: glider with m = 350 kg (772 lbs)

PA ft (m)	0°C (32°F) OAT		10°C (50°F)		20°C (68°F)		30°C (86°F)	
	ft/min	m/s	ft/min	m/s	ft/min	m/s	ft/min	m/s
SL	1610	8.2	1540	7.8	1480	7.5	1410	7.2
1000 (305)	1540	7.8	1475	7.5	1410	7.2	1345	6.8
2000 (610)	1475	7.5	1400	7.1	1340	6.8	1275	6.5
3000 (914)	1400	7.1	1335	6.8	1270	6.4	1210	6.1
4000(1219)	1330	6.8	1265	6.4	1200	6.1	1140	5.8
5000(1524)	1260	6.4	1195	6.1	1130	5.7	1070	5.4
6000(1829)	1190	6.0	1130	5.7	1065	5.4	1000	5.1
7000(2134)	1120	5.7	1060	5.4	995	5.1	935	4.7
8000(2438)	1050	5.3	990	5.0	925	4.7	865	4.4

Tow force: glider with m = 600 kg (1323 lbs)

PA ft (m)	0°C (32°F) OAT		10°C (50°F)		20°C (68°F)		30°C (86°F)	
	ft/min	m/s	ft/min	m/s	ft/min	m/s	ft/min	m/s
SL	1280	6.5	1210	6.1	1150	5.8	1080	5.5
1000 (305)	1210	6.1	1145	5.8	1080	5.5	1015	5.2
2000 (610)	1140	5.8	1080	5.5	1010	5.1	950	4.8
3000 (914)	1080	5.5	1005	5.1	940	4.8	880	4.5
4000(1219)	1005	5.1	935	4.7	870	4.4	810	4.1
5000(1524)	935	4.7	870	4.4	800	4.1	740	3.8
6000(1829)	865	4.4	800	4.1	735	3.7	675	3.4
7000(2134)	800	4.1	730	3.7	670	3.4	605	3.1
8000(2438)	730	3.7	670	3.4	600	3.0	545	2.8

Tow force: glider with m = 765 kg (1687 lbs)

PA ft (m)	0°C (32°F) OAT		10°C (50°F)		20°C (68°F)		30°C (86°F)	
	ft/min	m/s	ft/min	m/s	ft/min	m/s	ft/min	m/s
SL	920	4.7	850	4.3	785	4.0	725	3.7
1000 (305)	850	4.3	780	4.0	720	3.7	655	3.3
2000 (610)	780	4.0	715	3.6	650	3.3	585	3.0
3000 (914)	710	3.6	645	3.3	580	2.9	515	2.6
4000(1219)	645	3.3	575	2.9	510	2.6	450	2.3
5000(1524)	575	2.9	505	2.6	445	2.3	380	1.9
6000(1829)	505	2.6	440	2.2	375	1.9	310	1.6
7000(2134)	435	2.2	370	1.9	305	1.5	240	1.2
8000(2438)	365	1.9	300	1.5	235	1.2	180	0.9

920.6 WEIGHT AND BALANCE

Not affected.

920.7 DESCRIPTION OF THE SYSTEM

The release mechanism is a typ "E 85" of the "TOST" company, Munich. It is mounted at the tail spring rear end aft the tail wheel and activated with a yellow handle located at the rear seat cockpit via a bowden cable.

920.8 HANDLING, SERVICING AND MAINTENANCE

Service and maintenance needs to be conducted in accordance with the latest operation handbook (Typ E 85) of the manufacturer TOST GmbH, Germany. Additionally during the 100 h inspection the bowden cable and the release handle have to be checked.

SECTION 921

**AIRPLANES REGISTERED IN BRAZIL AND OPERATING UNDER THE
AGÊNCIA NACIONAL DE AVIAÇÃO CIVIL REQUIREMENTS**

Table of Contents

<i>Paragraph</i>		<i>Page</i>
921.1	GENERAL	3
921.2	LIMITATIONS	4
921.2.1	KINDS OF OPERATIONAL LIMITS	4
921.2.2	OPERATING PLACARDS	4
921.3	EMERGENCY PROCEDURES	4
921.4	NORMAL PROCEDURES	4
921.5	PERFORMANCE	4
921.6	WEIGHT & CENTER OF GRAVITY	4
921.7	SYSTEM DESCRIPTION	4
921.8	HANDLING, SERVICING AND MAINTENANCE	5

<p>EASA Approved On Behalf of ANAC of Brazil</p> <p>_____ Date: (Maximilian Maas) European Aviation Safety Agency</p>

Left blank intentionally

921.1 GENERAL

This supplement is approved by the EASA on behalf of the „Agência Nacional de Aviação Civil“ – ANAC for Brazilian registered aircraft, in accordance with the „Regulamento Brasileiro da Aviação Civil“ – RBAC 21, Section 21.29.

The information contained within this supplement is to be used in conjunction with the basic AFM/ POH and supplements. The information contained herein supplements or supersedes that in the basic manual and approved supplements only in those areas indicated.

The following POH/AFM supplements are ANAC approved:

Section	Title
901	Steerable Tail Wheel
902	Electric Pedal Adjustment
903	Cabin Heating System
904	Accelerometer TL-3424_EXT
905	External Power
906	Digital RPM Indicator
907	Smoke System
908	Single Seat Canopy
909	ARTEX ME-406 ELT
910	NAT AA83-001 Intercom
911	BECKER ATC 4401 Transponder
912	BECKER BXP 6401 Transponder
913	GARMIN GTX 327 Transponder
914	GARMIN GTX 328 Transponder
915	GARMIN GTX 330 Transponder
916	GARMIN GNC 420W / GNS 430W
917	ASPEN EFD1000/500 System
919	Landing Light
920	Airtow Hook
922	Garmin GTN 635/650/750
923	funke TRT800H Transponder

Compliance with the limitations contained in the basic manual and approved supplements is mandatory.

Foreign operating rules and any references to such rules in the basic manual and approved supplements are not applicable in Brazil. The aircraft must be equipped and operated in accordance with Brazilian operating requirements.

NOTE

A Kinds of Operation Equipment List may not necessarily apply in Brazil.

921.2 LIMITATIONS

921.2.1 KINDS OF OPERATIONAL LIMITS

Operation is limited to VFR-day. Use of GPS is prohibited as primary means for navigation. Optional GPS is approved as supplemental means for navigation only.

Wide Area Augmentation System (WAAS) functionality:

Since the WAAS is not available in Brazil, any kind of Global Navigation Satellite System (GNSS) approaches is prohibited even though optional GPS System installed (e.g. *GARMIN GNC420W*) may be capable of receiving WAAS.

921.2.2 OPERATING PLACARDS

The following placard has to be attached to the aircraft replacing the related placard in English language:

**COMBUSTÍVEL
AVGAS 100/100LL**

(adjacent to both wing fuel tank filler caps and fuselage center fuel tank filler cap)

921.3 EMERGENCY PROCEDURES

Not affected.

921.4 NORMAL PROCEDURES

Not affected.

921.5 PERFORMANCE

Not affected.

921.6 WEIGHT & CENTER OF GRAVITY

Not affected.

921.7 SYSTEM DESCRIPTION

Not affected.

921.8 HANDLING, SERVICING AND MAINTENANCE

Not affected.

Left blank intentionally

SECTION 922
GARMIN GTN 635/650/750

Table of Contents

<i>Paragraph</i>		<i>Page</i>
922.1	GENERAL	922-3
922.2	LIMITATIONS	922-3
922.2.1	Placards	922-5
922.2.2	SD Card	922-5
922.2.3	Terrain	922-5
922.2.4	Traffic (TIS only)	922-5
922.2.5	Flight Planning/Calculation Functions	922-5
922.2.6	Glove use	922-6
922.2.7	Demo mode	922-6
922.3	EMERGENCY/ABNORMAL PROCEDURES	922-6
922.3.1	Emergency Procedures	922-6
922.3.2	Abnormal Procedures	922-6
922.4	NORMAL PROCEDURES	922-7
922.5	PERFORMANCE	922-7
922.6	WEIGHT & CENTER OF GRAVITY	922-8
922.7	SYSTEM DESCRIPTION	922-8
922.7.1	Touchscreen, Key and Knob Functions	922-8
922.7.2	Secure Digital Card	922-9
922.7.3	Selecting com/nav frequencies	922-9
922.7.4	Remote transponder operation	922-10
922.7.5	Remote audio panel operation (GTN 750 only)	922-12
922.7.6	Powering up the GTN 635/650/750	922-14
922.7.7	Map Page	922-15
922.7.8	Ground Operation	922-15
922.7.9	Traffic Display (Optional)	922-15
922.8	SCREEN CLEANING	922-15

Left blank intentionally

922.1 GENERAL

This Airplane Flight Manual Supplement (AFMS) is written for the Garmin GTN 635/650/750 units. The Garmin GTN 635 is a GPS (WAAS/SBAS capable) panel-mounted unit that includes an airborne VHF communications transceiver. The GTN 650 & 750 units include all of the features of the GTN 635 in addition to airborne VOR/localizer (LOC) and glideslope (G/S) receivers. The GTN 750 features a larger display.

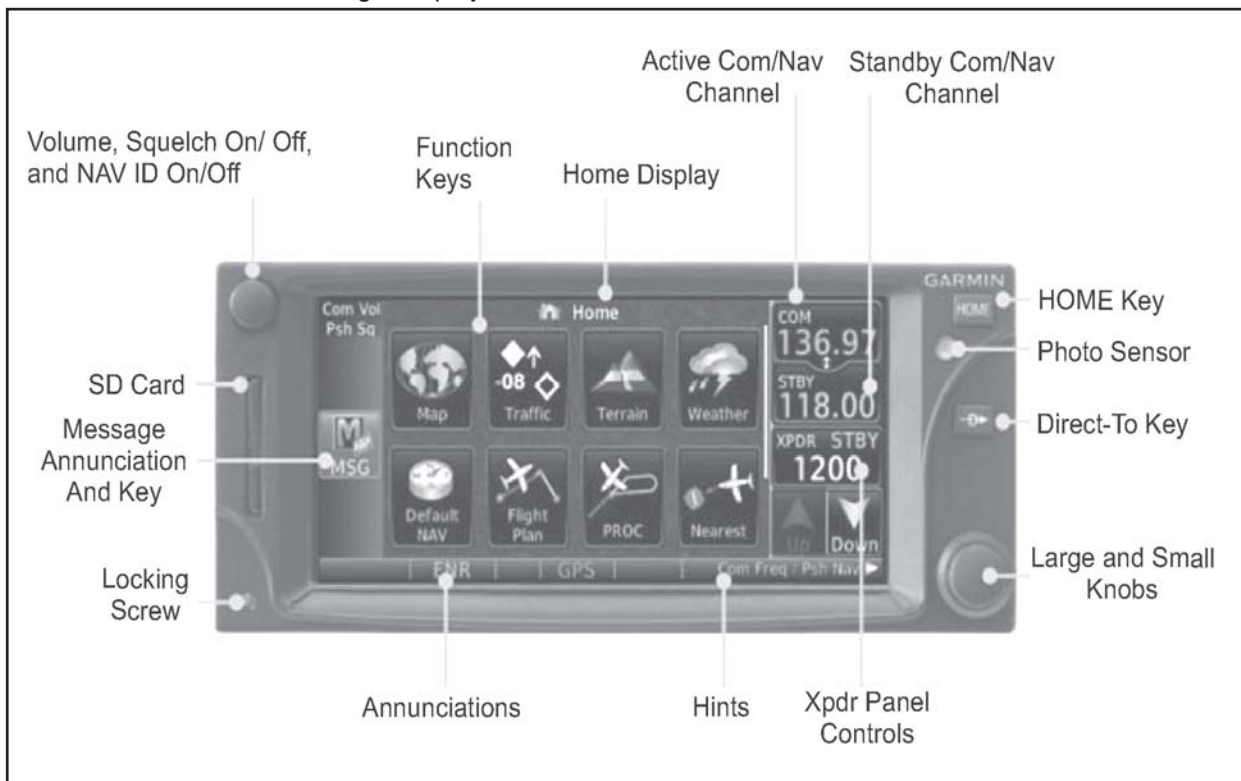

Figure 1, GTN 6xx Display Layout

All GTN units can be used to control the remote transponder GTX 33. The GTN 650 & 750 also feature NAV functionality. Additionally, the GTN 750 can be used to display Charts and to control the optional GMA 35 remote audio panel.

This supplement is written for main software version 2.00, GPS software version 4.0, COM software version 2.01 and NAV software version 6.01 and is not suitable for earlier software versions. Some differences in operation may be observed when comparing the information in this supplement to later software versions. Verify the information herein with the GTN Series Pilot's Guide & Cockpit Reference Guide (GTN 6xx P/N 190-01004-03 Issue B & P/N 190-01004-04 Issue C, GTN 750 P/N 190-01007-03 Issue B & P/N 190-01007-04 Issue B) you received with your unit. There you will also find further information.

922.2 LIMITATIONS

This supplement does not grant approval for IFR operations.

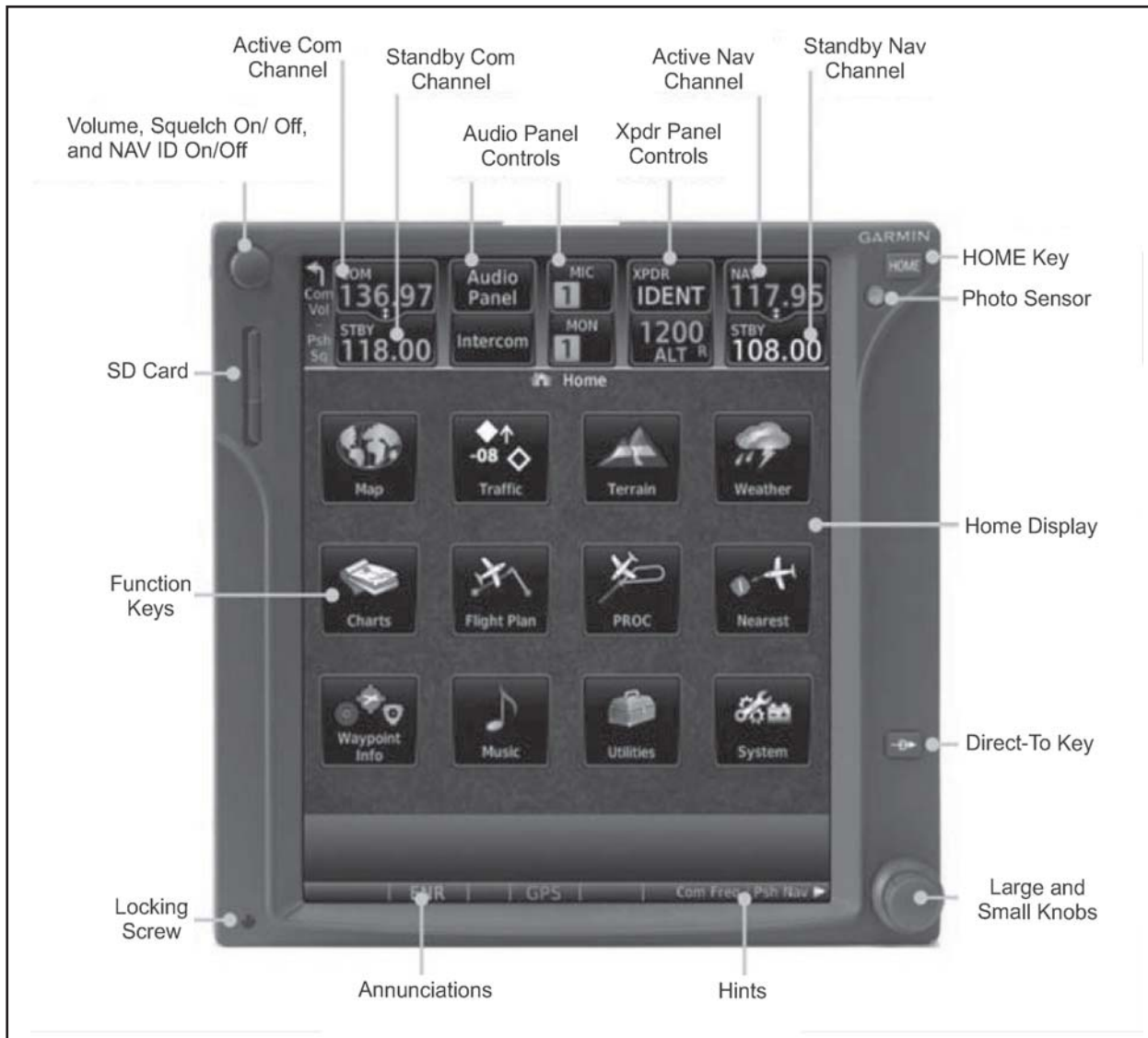

Figure 2, GTN 750 Display Layout

The system must utilize main software version 2.00, GPS software version 4.0, COM software version 2.01 and NAV software version 6.01 or later EASA/FAA approved versions. Valid and compatible databases must be installed and contain current data.

The navigation data incl. for final approach segments provided by the GTN series (e.g. moving map & CDI depiction) is for situational awareness only and should not be relied upon for navigation.

Do not use SafeTaxi or ChartView functions as the basis for ground maneuvering. SafeTaxi and ChartView are to be used for the pilot to orient himself on the airport surface to improve situational awareness during ground operation.

922.2.1 PLACARDS

**GARMIN GPS
limited to VFR use only**

(In close proximity to the GTN unit
in clear view of the pilot)

GPS

(Next to the GTN unit GPS circuit breaker)

INTERCOM

(Next to the GMA 35 Remote Audio Panel circuit breaker, if installed)

922.2.2 SDCARD

Proper function of any of the units is predicated on the SD card being present.

922.2.3 TERRAIN

Terrain proximity and obstacle information appears on the map and terrain display pages as red and yellow tiles or towers, and is depicted for advisory use only. Aircraft maneuvers and navigation must not be predicated upon the use of the terrain display. Terrain proximity and obstacle information is advisory only.

The terrain display is intended to serve as a situational awareness tool only. By itself, it may not provide either the accuracy or the fidelity on which to base decisions and plan maneuvers to avoid terrain or obstacles.

922.2.4 TRAFFIC (TIS ONLY)

Traffic may be displayed on the GTN when connected to an approved optional TIS traffic device. This system is capable of providing traffic monitoring and alerting to the pilot. Traffic shown on the display may or may not have traffic alerting available. The display of traffic is an aid to visual acquisition and may not be utilized solely for aircraft maneuvering.

922.2.5 FLIGHT PLANNING/CALCULATION FUNCTIONS

When using the calculator/planner pages data must be entered into all data fields and verified by the pilot prior to use of the data. The pilot must verify the desired altitude and appropriate barometric pressure setting to ensure valid calculations. Aircraft performance or fuel loading must not be predicated upon the use of data derived from these functions.

922.2.6 GLOVE USE

No device may be used to cover fingers used to operate the GTN unless the Glove Qualification Procedure located in the Pilot's Guide has been successfully completed. The Glove Qualification Procedure is specific to a pilot/glove/GTN unit combination.

922.2.7 DEMO MODE

Demo mode may not be used in flight under any circumstances.

922.3 EMERGENCY/ABNORMAL PROCEDURES

922.3.1 EMERGENCY PROCEDURES

LOSS OF REMOTE AUDIO PANEL FUNCTIONS (IF INSTALLED WITH GTN 750)

Pull INTERCOM circuit breaker

NOTE

This procedure will restore COM operation on the GTN 750. The intercom functions will not be available.

922.3.2 ABNORMAL PROCEDURES

GPS NAVIGATION INFORMATION NOT AVAILABLE OR INVALID

If GTN 635/650/750 GPS navigation information is not available or invalid the GTN will enter one of two modes: Loss of Integrity (LOI) mode or Dead Reckoning (DR) mode. Utilize remaining operational navigation equipment as appropriate.

A) LOSS OF INTEGRITY MODE

If the amber Loss of Integrity (LOI) Mode message is displayed, revert to an alternate means of navigation appropriate to the route and phase of flight or periodically cross-check the GPS guidance to other, approved means of navigation.

B) DEAD RECKONING MODE

If the amber Dead Reckoning (DR) Mode message is displayed, the course guidance will be removed from the CDI. The airplane position will be based on the last valid GPS position, then estimated by Dead Reckoning methods. All information normally derived from GPS will become less accurate over time.

SEARCHING A NEARBY AIRPORT

To select a nearby airport as a direct-to waypoint:

1. Press the **Direct-To** key on the right side of the unit.
2. Touch the **NRST APT** tab in the Direct-To window. The nearest 25 airports within 200NM will be listed. The airport at the top of the list is the nearest airport. To review the other nearest airports, touch the **Up** and **Down** keys to scroll through the list.
3. Touch the desired airport to select it. The selected airport will be displayed in the Waypoint page.
4. Touch the Activate key or press the **small right** knob to activate the selection.
5. The Map page will now be displayed with the new **Direct-To** course.

922.4 NORMAL PROCEDURES

TO ACTIVATE AN EXISTING FLIGHT PLAN:

1. Press the **Direct-To** key on the right side of the unit.
2. Touch the **FPL** tab in the **Direct-To** window.
3. Touch the flight plan waypoint you want to navigate directly to. The Direct-To Waypoint page will display information about the selected flight plan waypoint.
4. Touch the **Activate** key or press the **small right** knob to activate the selection.
5. The Map page will now be displayed with the new Direct-To course.

922.5 PERFORMANCE

Not affected.

922.6 WEIGHT & CENTER OF GRAVITY

Refer to the equipment list in Section 6 of this Handbook.

922.7 SYSTEM DESCRIPTION

922.7.1 TOUCHSCREEN, KEY AND KNOB FUNCTIONS

Controls are a combination of a dual concentric rotary knob and push-keys on the bezel with the color display providing information as well as active touch areas on the display.

TOUCHSCREEN

The GTN 635/650/750 units feature a touch panel that provides a visual display of both controls and functions. The required controls are displayed for the selected function. Keys on the display allow you to access and control their functions by touching the interactive display. A list of menu items may be scrolled by touching the screen and retaining pressure while sliding your finger up or down. Map displays may be panned by touching the screen and retaining pressure while sliding your finger in the desired direction.

Touchscreen keys are placed at the lower portion of the display. The keys vary depending on the page selected. Touch the key to perform the function or access the described information.

You can return to the previous page or exit the current function by touching the **Back** key.

KEYS

Quickly return to the Home page by pressing the **HOME** key. Press and hold the **HOME** key to reach the Map page.

The **Direct_To** key provides access to the direct-to function, which allows you to enter a waypoint and establishes a direct course to the selected destination.

KNOBS

The **Volume** knob controls audio volume for the selected COM radio or NAV receiver (if installed) and any external audio input devices (if installed). When the COM radio is active, press the **Volume** knob momentarily to disable automatic squelch control for the COM radio. When the NAV radio is active, press the **Volume** knob momentarily to enable/disable the ident tone for the NAV radio.

The **large right** and **small right** knobs are used for data entry and to set the frequencies for the communications transceiver or the VOR/Localizer receiver (if installed).

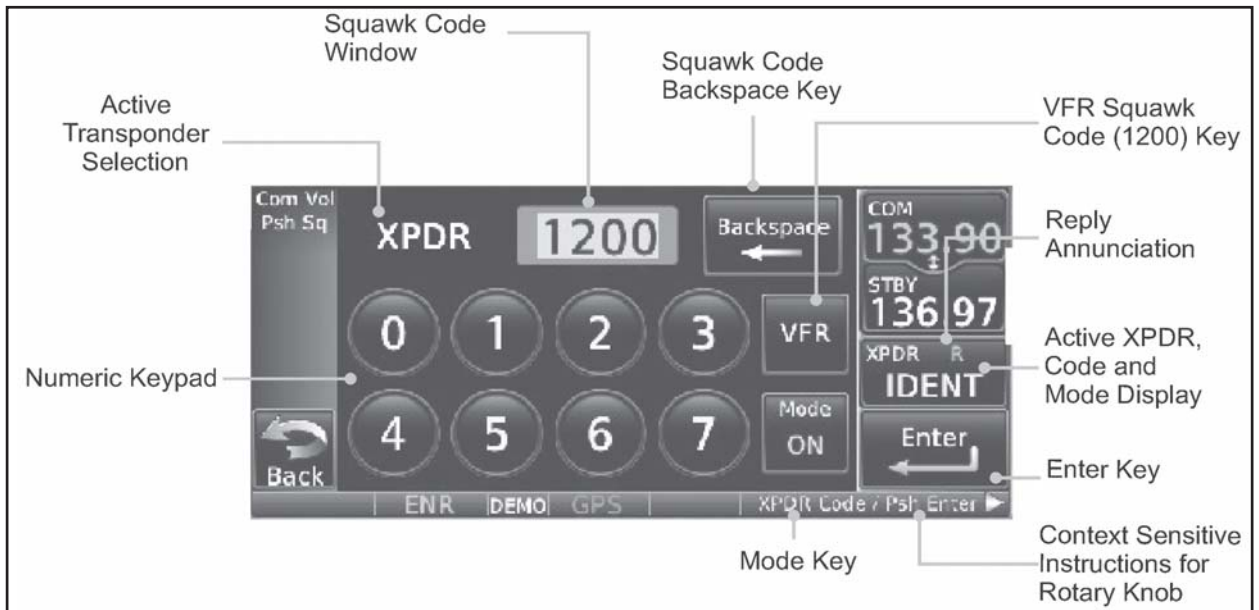

Figure 3, GTN 6xx XPDR Operation

922.7.2 SECURE DIGITAL CARD

A Secure Digital (SD) card is used to load and store various types of data and for various database updates. Ensure the GTN unit is powered off before inserting or removing an SD card.

922.7.3 SELECTING COM/NAV FREQUENCIES

Tuning control normally remains in the COM window and will return after 30 seconds of inactivity.

USING KNOBS

Press the **small right** knob momentarily to make the NAV window active for editing. The standby frequency in blue is active for editing. Turn the **large right** knob to select the desired megahertz (MHz) value. Turn the **small right** knob to select the desired kilohertz (kHz) value. Press the **small right** knob to transfer the standby frequency to the active window.

USING TOUCHSCREEN

Touch the Standby window. A pull down keypad will appear with the current Standby frequency highlighted. Touch the numeric keys to add the desired values and touch **Enter** to accept the displayed value and place it into the Standby window. Touching the **XFER** key will place the selected frequency directly in the Active window. Touch the Active (top) frequency window to flip/flop the Active and Standby frequencies.

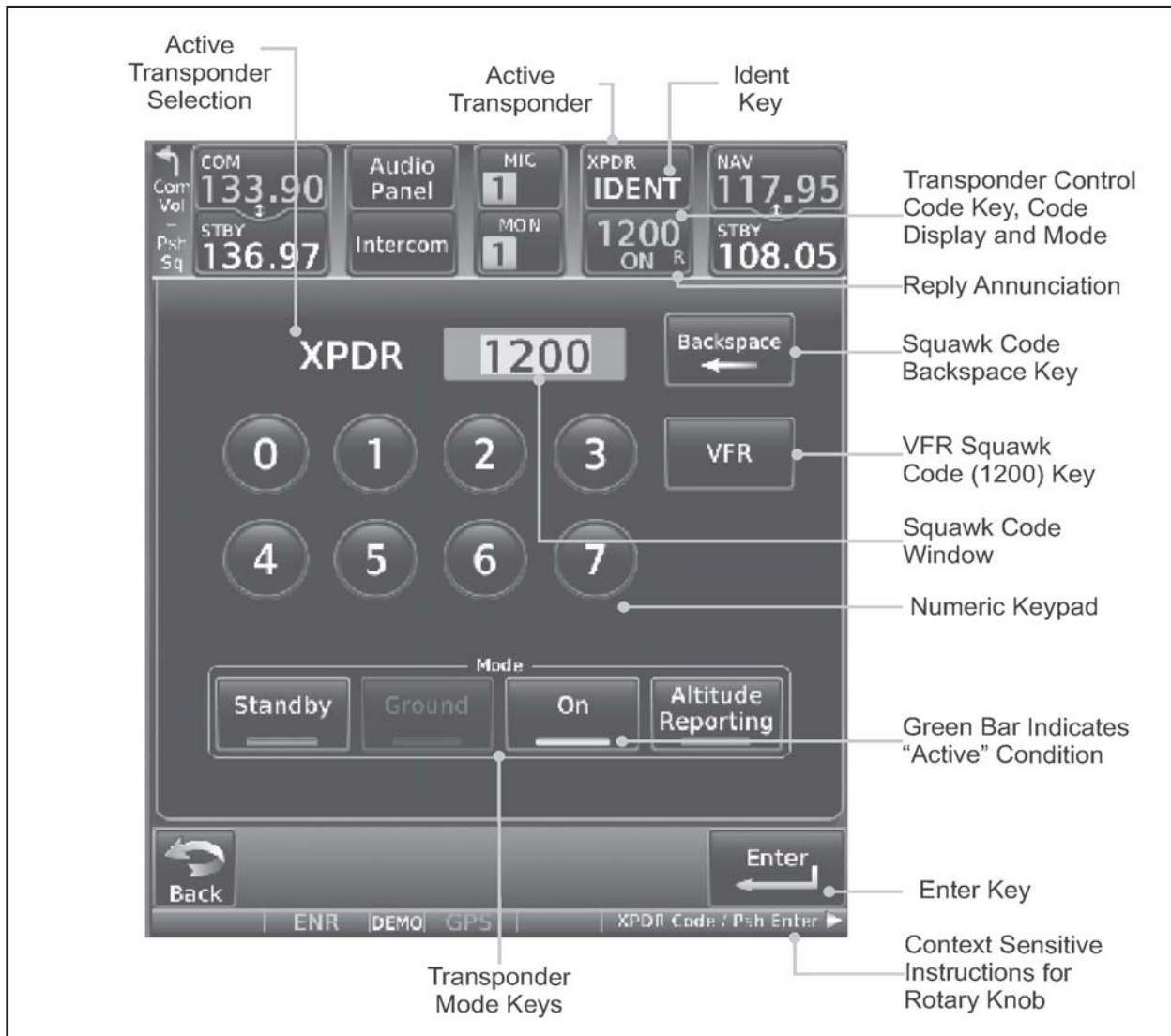

Figure 4, GTN 750 XPDR Operation

922.7.4 REMOTE TRANSPONDER OPERATION

Optionally, a remote transponder (GTX 33) can be controlled via the GTN 635/650/750 unit. Touch the transponder window to enter the transponder operation page. See figures 3 and 4 for the GTN 6xx and the GTN 750 respectively.

IDENT

1. Touch the **IDENT** key once to reply with an identifying squawk code.
2. The **IDENT** key text will change to green to indicate active Ident.

STANDBY

1. Touch the **Mode** key to show a list of available modes (directly accessible from the transponder operation page on the GTN 750). Touch the **Standby** key to place the transponder into Standby mode. The transponder will still be powered, but will not transmit information. The active transponder indication and Ident annunciation will be grayed to show they are disabled.

GROUND

1. Touch the **Ground** key to place the transponder into Ground mode. Mode S replies will be allowed in Ground mode.

ON

1. Touch the **On** key for Mode A operation. The transponder is "On" and will transmit its squawk code when interrogated.

ALTITUDE REPORTING

1. Touch the **Altitude Reporting** key for Mode C operation.
2. The transponder will be "On" and will transmit its squawk code and altitude when interrogated. An "ALT" annunciation will appear when the squawk code is transmitted.

VFR

1. Touch the **VFR** key to set the VFR squawk code (1200 or 7000 depending on location, see below).

SELECTING A SQUAWK CODE

The selected squawk code will always be in use. As you change the squawk code, the original code will be used until you are finished selecting the new code.

1. Touch the transponder squawk code window at the top of the display.
 2. The XPDR page will be displayed. The Squawk Code value will be active for selection for use by the active transponder.
 3. Touch the numeric keypad, or use the rotary knobs, to select the desired Squawk Code.
 4. Then, touch **Enter** or press the **small right** knob.
 5. The selected Squawk Code will be shown in the XPDR window at the top of the display.
-

IMPORTANT CODES:

1200 The VFR code for any altitude in the US (Refer to ICAO standards elsewhere)

7000 The VFR code commonly used in Europe (Refer to ICAO standards)

7500 Hijack code (Aircraft is subject to unlawful interference)

7600 Loss of communications

7700 Emergency

7777 Military interceptor operations (Never squawk this code)

0000 Military use (Not enterable)

Avoid selecting code 7500 and all codes in the 7600-7777 range. These trigger special indicators in automated facilities. Only the code 7500 will be decoded as the hijack code. An aircraft's transponder code (if available) is utilized to enhance the tracking capabilities of the ATC facility, therefore care should be taken when making routine code changes.

NOTE

When an Aspen EFD1000 PFD is installed, it is used as the encoded altitude source. Do not power down the Aspen PFD while using the Garmin GTN 635/650/750 unit or the Garmin GTX 33 remote transponder.

922.7.5 REMOTE AUDIO PANEL OPERATION (GTN 750 ONLY)

The remote audio panel (GMA 35) can be operated from the GTN 750 only. It incorporates an intercom functionality. The Passenger Address, Cabin Speaker, Marker Beacon and Telephone functionalities are not used. See Figure 5 for the GTN750 audio panel operation page.

MIC WINDOW MIC SELECTION

1. Touch the **Mic** window to toggle between Mic 1 and Mic 2.
2. Note that the selected Mic is automatically monitored.

AUDIO PANEL PAGE MIC SELECTION

1. Touch the **Audio Panel** key at the top of the display.
2. Touch the desired Mic from the MIC Selection list on the right side of the display.

3. The selected Mic will be shown in the MIC window.

MONITOR

1. Monitor is automatically selected for the associated Com Mic Radio.
2. Touch the **Mon** key to toggle between the automatically selected monitored channel (selected Mic) and the other available channels.

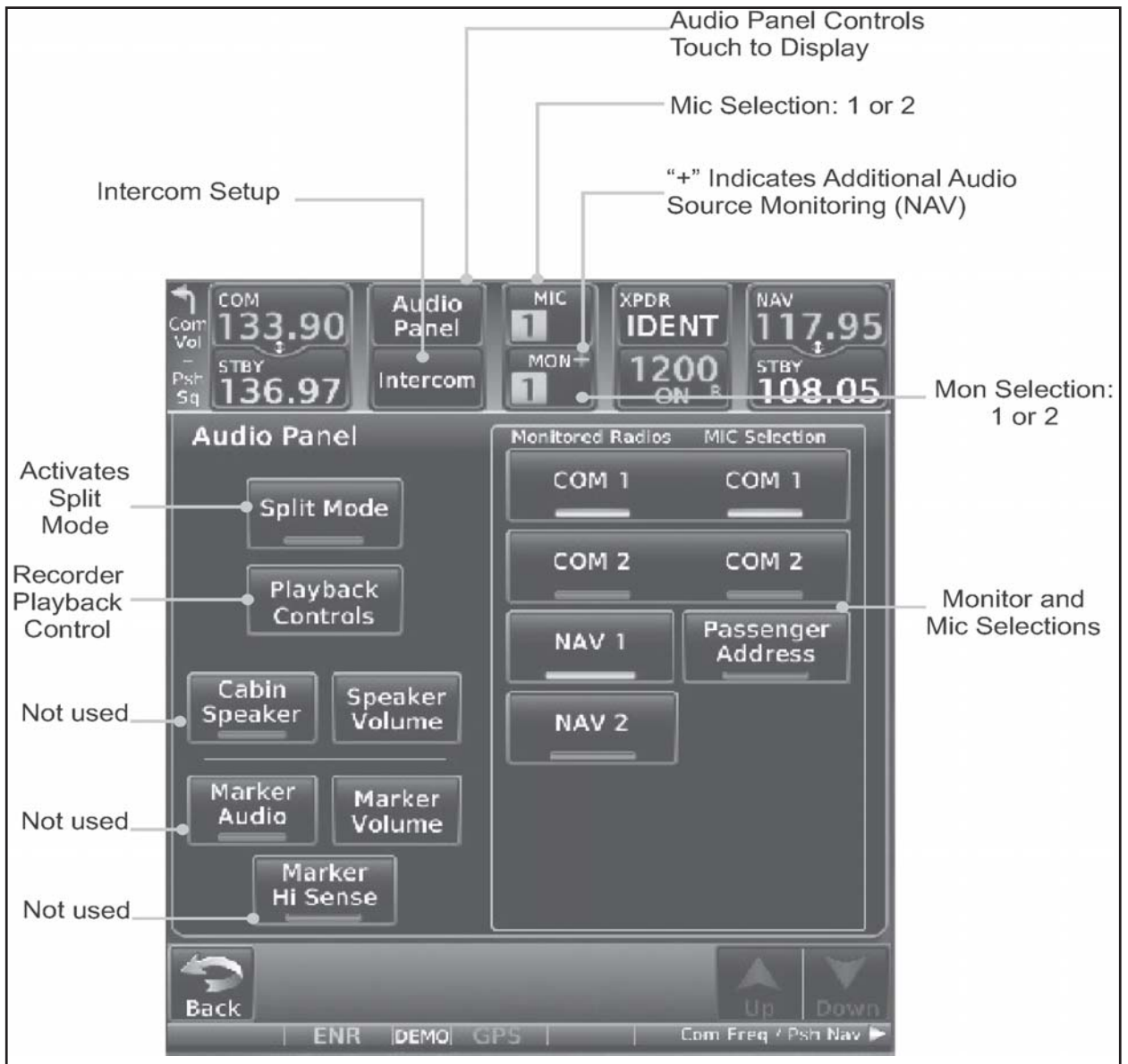

Figure 5, GTN 750 Audio Panel Operation

PLAYBACK CONTROLS

1. While the Audio Control page is displayed, touch the **Playback Controls** key to display the Playback Controls selections.
2. Touch the **Playback Volume** arrows to set volume.
3. Touch the **Backward**, **Play** or **Forward** keys to control the playback of the currently selected recording.
4. Touch the **Previous** or **Next** keys to select a recording.

INTERCOM SETUP

1. Touch the **Intercom** window at the top of the display to display the intercom Setup page.
2. Touch the arrow between the Pilot and CO-Pilot to activate communication between those recipients. The arrow will be green when communication is active. Touch the arrow again to deactivate communication.
3. Touch the **Pilot** or **Co-Pilot** keys to set the Volume and Squelch for the selected item.
4. Touch the **Volume** arrows to set the desired Volume level.
5. Touch the **Auto Squelch** key to allow the unit to set the Squelch level automatically. When enabled, the **Auto Squelch** key will display a green bar.
6. Touch the **Squelch** arrows to set the desired Squelch level.
7. Touch the **Back** key to return to the Intercom Setup page.
8. Touch the **Music 1** or **Music 2** keys to set their configuration.
9. Select the recipients for Music Distribution by touching any combination of the **Pilot** and **Co-Pilot** keys.
10. Touch the **Radio** and/or **Intercom keys** to select the function that when active Music will be muted.
11. Touch the **Volume** arrows to set the desired Volume level.

922.7.6 POWERING UP THE GTN 635/650/750

The GTN 635/650/750 power and COM volume are controlled using the power/volume knob at the top left corner of the unit. Turning it clockwise will turn unit power on and increase the COM radio volume. After turning the unit on, several system startup pages will be displayed: A copyright page, a software & database versions and dates page and a self-test page. The database confirmation page shows the current database information on the NavData card (with the valid operating dates, cycle number and database type indicated). The database is updated every 28 days, and must be current. Information on database subscriptions is available inside your GTN 635/650/750 package.

To acknowledge or advance to the next page, touch **Continue**.

922.7.7 MAP PAGE

During most flights, the *Map page* will be used for situational awareness. The *Map page* displays Airports, NAVAIDs, airspace, airways, land data (highways, cities, lakes, rivers, borders, etc.) with names, wind direction and speed, icons for enabled map features, aircraft icon (with the nose representing present position), nav range ring, flight plan legs, a graphic course deviation indicator (CDI) with From - To - Next waypoints, topography scale, terrain overlay.

The *Map page* is reached by touching the MAP key on the Home page or by pressing and holding the Home key.

922.7.8 GROUND OPERATION

NOTE

Do not use SafeTaxi or Chartview functions as the basis for ground maneuvering. SafeTaxi and Chartview functions are not qualified to be used as an airport moving map display (AMMD).

SafeTaxi and Chartview are to be used by the flight crew to orient themselves on the airport surface to improve pilot situational awareness during ground operations.

922.7.9 TRAFFIC DISPLAY (OPTIONAL)

Traffic may be displayed on the GTN when connected to an approved TIS traffic device (e.g. GTX 330 or GTX 33). The TIS information is only available in the US. The Garmin GTN 6xx or 7xx Cockpit Reference Guide or Pilot's Guide provides additional information regarding the functionality of the traffic device.

The display of traffic is an aid to visual acquisition and may not be utilized solely for aircraft maneuvering.

922.8 SCREEN CLEANING

The Clean Screen mode makes the touchscreen inactive so the display can be manually cleaned. The front bezel, keypad, and display can be cleaned with a microfiber cloth or with a soft cotton cloth dampened with clean water. **DO NOT** use any chemical cleaning agents. Care should be taken to avoid scratching the surface of the display.

While viewing the Utilities page group, touch the **Clean Screen** key to start the Screen Cleaning Mode. Touch the **HOME** key to exit Screen Cleaning Mode.

Left blank intentionally

SECTION 923

f.u.n.k.e. TRT800H TRANSPONDER

Table of Contents

<i>Paragraph</i>		<i>Page</i>
923.1	GENERAL	923-3
923.1.1	Features	923-3
923.1.2	Operation	923-4
923.1.3	Display-Contrast	923-6
923.1.4	Flight-ID (FID)	923-6
923.1.5	Display Flight-ID	923-6
923.1.6	Configure Flight-ID	923-6
923.1.7	Transponder Mode selection	923-7
923.1.8	Squawk-Setting	923-7
923.1.9	VFR – Squawk	923-8
923.1.10	ID – Special Position Identification (SPI): “Squawk Ident”	923-8
923.1.11	Error-Codes	923-8
923.2	LIMITATIONS	923-9
923.3	EMERGENCY PROCEDURES	923-9
923.3.1	Important Codes	923-9
923.4	NORMAL PROCEDURES	923-9
923.5	PERFORMANCE	923-9

Left blank intentionally

923.1 GENERAL

NOTE

In order to operate the Mode S transponder it is necessary to request an ICAO 24-bit Aircraft Address at the responsible national aviation authorities. The received Code is assigned to the specific transponder/aircraft and must be configured within the transponder. The 24-bit address is stored in an external memory which allows the transponder being exchanged without requiring any further configuration.

NOTE

The TRT800H owner accepts all responsibility for obtaining the proper license before using the transponder. For this purpose and for detailed and further information refer to f.u.n.k.e. TRT800H Operation and Installation Manual (Doc. No. 03.2125.010.71e).

923.1.1 FEATURES

- Class 1 Level 2es non-diversity Mode S transponder for ground based interrogations at 1030 MHz and response at 1090 MHz
- Replies to (Secondary) Radar Interrogations
 - Mode A replies with a Squawk (one of 4096 possible Codes; e.g. flight plan number, Squawk assigned by a controller or the VFR Squawk 7000)
 - Mode C replies, including encoded flight level
 - Mode S replies, including aircraft address and flight level
 - Extended Squitter, containing additional information on position and velocity
- IDENT capability for activating the „Special Position Identification“- Pulse (SPI) for 18 seconds, which is requested by the Controller „Squawk Ident“
- Display information contains Squawk code, mode of operation and pressure altitude.
- Temperature compensated high precision piezo-resistive pressure sensor
- 8 storable entries for AA-/AC-Code, FID, Ground-Switch, RI-Code and GPS-/Interface-setting (stored in external memory TRT800EMxx)

923.1.2 OPERATION

CONTROLS

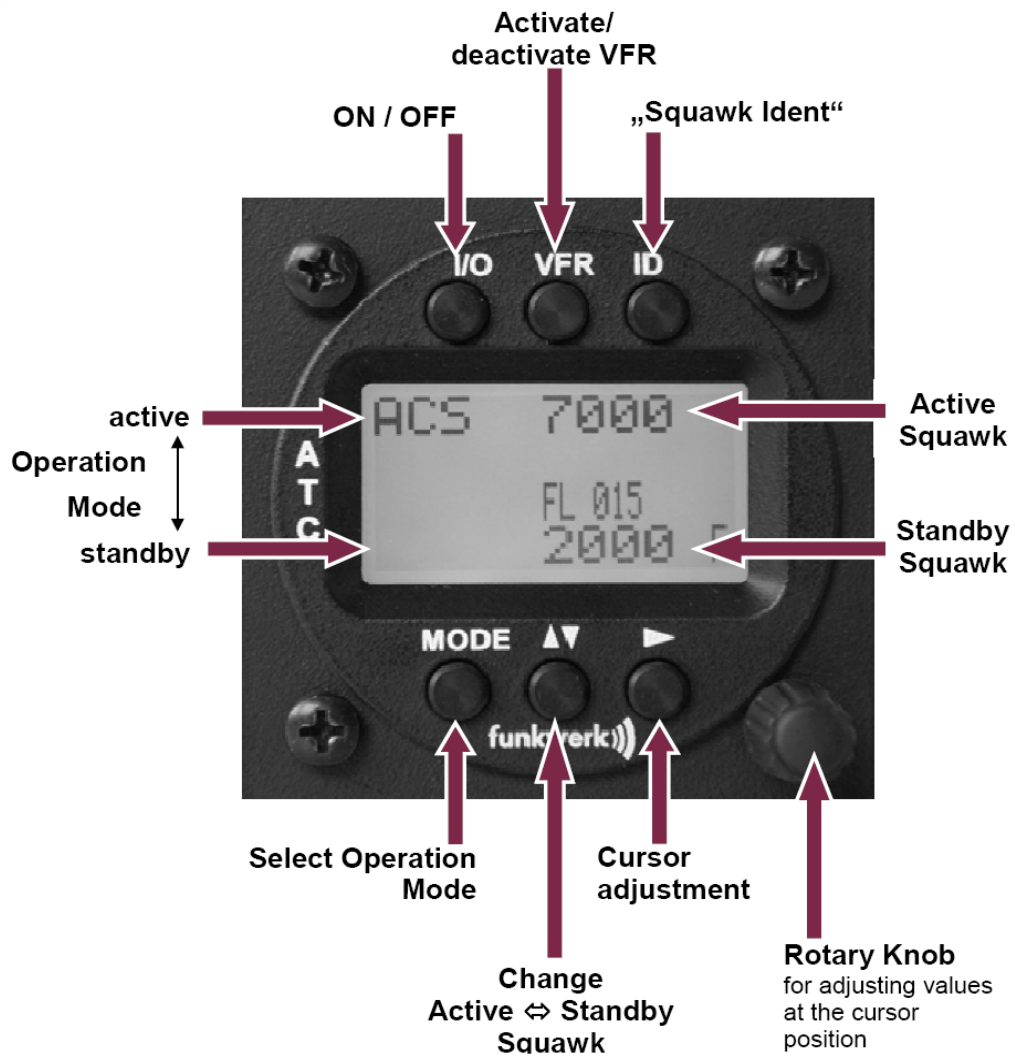

I/O ON/OFF

Switch ON: press **I/O** button for approx. 0,5 s

Switch OFF: press **I/O** button for approx. 3 s

VFR VFR

activate/deactivate VFR Squawk (press shortly)

store active Squawk as VFR/VFRW-Squawk (press button 3 s)

▼▲CHANGE

change between active and standby-Squawk

works as cursor back button (opposite function of the cursor button) during entering values and also for navigating backwards through the configuration menu.

ID IDENT

„Squawk Ident“, sends Ident marking (SPI) for 18 s

Enter Flight-ID (FID) setup (in standby mode, press button for approx. 5s)

MODE MODE

Select transponder operational mode

► CURSOR

Set position of Cursor

● Rotary Knob

Adjust/Enter values at current cursor position, select options; set standby Squawk

DISPLAY

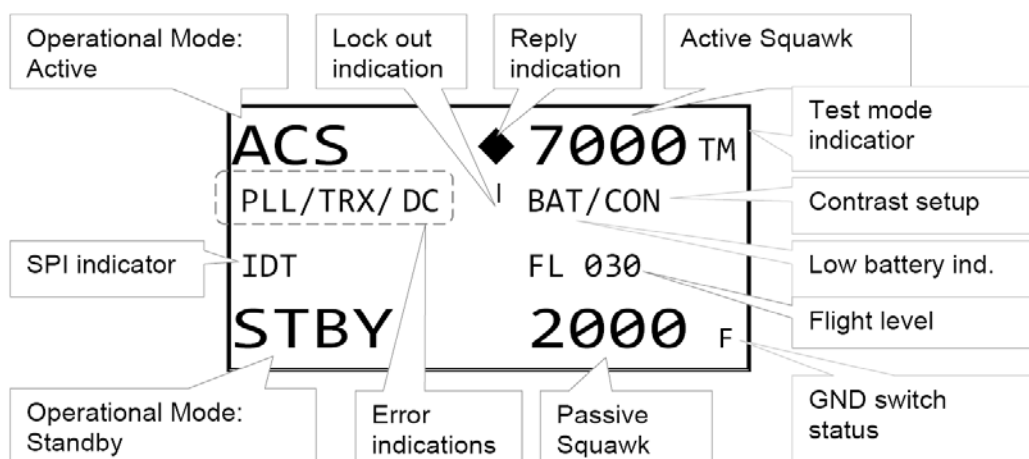

923.1.3 DISPLAY-CONTRAST

In active mode (not standby) press ► for 2 s.

Display indicates "CON" Now adjust contrast (CON) with **rotary knob**.

Return to normal operation: press ► or wait 5 s.

923.1.4 FLIGHT-ID (FID)

The FID is an identifier required for Mode S Operation. During future application of flight plans a FID could be assigned on a per flight basis. If no FID is assigned (today's normal case) the registration marking of the aircraft should be used as FID. The FID should not contain dashes or blanks. The FID must not be confused with the 24-bit Aircraft Address.

923.1.5 DISPLAY FLIGHT-ID

Press **MODE** (repeatedly) until „STBY“ appears

Press and hold **ID** while a counter is shown beside the active squawk.

During a few seconds Flight Identification is displayed.

923.1.6 CONFIGURE FLIGHT-ID

Press **MODE** (repeatedly) until „STBY“ appears

Press and hold **ID** while a counter is shown beside the active squawk.

Release **ID** when "CHANGE FID" is displayed

NOTE

Enter FID left-aligned, without any blanks or dashes (!), e.g. 12345621DEFAV for the marking D-EFAV. The last remaining digits shall be filled with blanks.

Enter Flight-Id with ► and **rotary knob**.

Press **MODE** to save and return to STBY

Please refer to TRT800H Operation and Installation Manual (Doc. No. 03.2125.010.71e) Section 4.5.4 for configuration of the 24-bit Address (AA) and Aircraft Category (AC).

923.1.7 TRANSPONDER MODE SELECTION

Press **MODE** (repeatedly) to select from following Modes:

- **STBY** „Standby“
Transponder does not respond to any interrogation. Squitter and ADS-B output is not active.
- **A C S** „Mode A+C+S“
Standard condition; transponder responds to mode A, C and S interrogations.
- **A – S** „Mode A+S, no C“
Altitude is not transmitted (neither on C nor on S requests). All other Mode-S data as well as Mode-A replies are transmitted.

If no 24-bit address (AA) was defined or entered as “000000” the transponder operates as a Mode A/C transponder, in that case the following Modes are possible apart from Standby:

- **A C –** „Mode A+C“
Transponder replies only on Mode A and Mode-C interrogations.
- **A – –** „Mode A“
Transponder replies only on Mode A interrogations.

NOTE

In STBY (Standby) mode, all transponder transmissions are disabled completely! Therefore, the transponder is not visible in this mode to air traffic control or the anti-collision systems onboard other aircraft.

Never use the STBY mode in flight unless you are requested to do so by air traffic control. Always remember to put the transponder in active mode prior to take off!

923.1.8 SQUAWK-SETTING

The active Squawk is displayed in the upper line, while the standby Squawk is presented at the lower line.

Setting the Standby Squawk:

- Press **▶** to set the cursor („^“), turn **rotary knob** to set numbers of the standby Squawk.
- Press **▼▲** to activate the Standby Squawk (this moves the current active Squawk into Standby)

923.1.9 VFR – SQUAWK

The transponder features a user-defined squawk code for VFR-flight (factory setting: 7000):

- **Activate VFR-Squawk:**
Press **VFR** („VFR“ is indicated), now the active Squawk is moved into Standby but not visible because the indication of the Standby Squawk is overlapped by „VFR“
- **Display Standby Squawk:**
Press **VFR** or **▼▲** or use the **rotary knob** (the VFR Squawk remains active!)
- Now the Standby Squawk can be adjusted by using the **rotary knob** and activated with **▼▲**.
- In order to store the current active Squawk as new VFR-Squawk (replacing the factory setting 7000):
Press and hold **VFR** until an „S“ is indicated (approx. 3 s); after releasing the button „VFR“ is shown.

923.1.10 ID – SPECIAL POSITION IDENTIFICATION (SPI): “SQUAWK IDENT”

Press **ID** to activate transmission of the special position identification pulse with every reply within 18 seconds; “IDT” appears on the display

By pressing **ID** a special position identification pulse (SPI) is transmitted with every reply within 18 seconds, which causes an accented marking on the controller's screen. The „Special Position Identification“ has to be activated after the „Squawk Ident“ request of the controller.

923.1.11 ERROR-CODES

Value	Meaning	Remarks
PLL	PLL Error	Internal Error
TRX	Transmit Failure	Check antenna and wiring
DC	Low internal voltage	Internal error
FPG	FPGA Failure	Internal error
BAT	Battery Power too low	maybe battery/generator fault

923.2 LIMITATIONS

Not applicable.

923.3 EMERGENCY PROCEDURES

923.3.1 IMPORTANT CODES

7600 Loss of communications.

7500 Hijacking.

7700 Emergency (All secondary surveillance radar sites are ready to receive this code at all times).

See the Airman's Information Manual (AIM) for a detailed explanation of identification codes.

923.4 NORMAL PROCEDURES

Not applicable.

923.5 PERFORMANCE

Not applicable.

Left blank intentionally

SECTION 924
KANNAD 406 AF COMPACT/INTEGRA ELT

Table of Contents

<i>Paragraph</i>		<i>Page</i>
924.1	GENERAL	924-3
924.2	LIMITATIONS	924-3
924.3	EMERGENCY PROCEDURES	924-4
924.4	NORMAL PROCEDURES	924-4
924.5	PERFORMANCE	924-5
924.6	WEIGHT & CENTER OF GRAVITY	924-5
924.7	SYSTEM DESCRIPTION	924-5
924.7.1	Switch Operation	924-6
924.8	HANDLING, SERVICING AND MAINTENANCE	924-6
924.8.1	Periodic Inspection	924-6
924.8.2	Battery Replacement	924-7

Left blank intentionally

924.1 GENERAL

To improve the passive security, the EXTRA 330LX can be equipped with an optional Emergency Locator Transmitter KANNAD AF 406 COMPACT or INTEGRA ELT.

In the event of a crash, the AF 406 activates automatically (automatic fixed „AF“ configuration), and transmits the standard swept tone on 121.5 MHz lasting until the battery is depleted. This 121.5 MHz signal is mainly used to pinpoint the beacon during search and rescue operations. In addition, for the first 24 hours of operation, a 406 MHz signal is transmitted at 50-second intervals. This transmission lasts 440 ms and contains identification data programmed into the beacon and is received by Cospas-Sarsat satellites. The transmitted data is referenced in a database (maintained by the national authority responsible for ELT registration) and used to identify the beacon and owner.

When the ELT is activated, the panel LED pulses periodically. The time between pulses lengthens after a predetermined transmitter 'on' time.

NOTE

In October 2000 the International Cospas-Sarsat Program, announced at its 25th Council Session held in London, UK that it plans to terminate satellite processing of distress signals from 121.5 and 243 MHz emergency beacons on February 1, 2009.

ACCURACY

Doppler positioning is employed using both 121.5 MHz and 406 MHz signals. Position accuracy of the 121.5 MHz signal is within an area of approximately 15-20 km radius about the transmitter. Due to the better integrity of the 406 MHz signal, its location accuracy is within about a 3 km radius.

924.2 LIMITATIONS

The operation limitations are not affected by the installation of the KANNAD AF 406 COMPACT or INTEGRA ELT.

For the operation of the transmitter the following placard is on the front face of the remote switch:



(on the ELT remote switch)

924.3 EMERGENCY PROCEDURES

- In case of a forced landing switch the remote switch in the rear instrument panel to the "ON" position prior to touch down.

Although the ELT will be activated automatically after an aircraft accident or forced landing with high G-force,

- switch additionally the remote switch in the rear panel to the "ON" position.

After sighting rescue aircraft:

- Switch the remote switch to the "ARM" position to prevent radio interference.
- Attempt contact with rescue aircraft with the radio transceiver set to a frequency of 121.5 MHz. If no contact is established, switch the remote switch to the "ON" position immediately.

If the function of the remote switch is in doubt proceed as follows:

- Remove quick pins from the backrest adjustment and swivel the backrest forward to get access to the ELT unit.
- Use the master switch at the ELT unit analogously.

FUNCTION CHECK OF THE ELT

- If the aircraft receiver is operable, check ELT function by listening on 121.5 MHz for ELT transmission. Ensure that the ELT antenna is clear of any obstructions.

924.4 NORMAL PROCEDURES

It is recommended by the manufacturer to test the ELT to detect any possible failure.

An operational check must be performed regularly by a pilot or maintenance personnel from the cockpit (Remote Control Panel). It is recommended to perform a self-test once a month but it **should not be done more than once a week.**

Each self-test consumes energy from the battery. Should self-tests be carried out more often than the maximum allowed, the battery life-time might be shorter than specified.

SELF-TEST PROCEDURE

- Check that the antenna is correctly connected

Do not perform self-test without antenna connected.

- Tune aircraft radio to 121.5 MHz and adjust volume to ensure you can hear it.

- Switch from position „OFF“ to position „ARM“ or press RESET & TEST on the Remote Control Panel (ensure that the ELT switch is in position „ARM“).

Close to the end of the self-test a short (3-4 sweeps) 121.5 transmission is made.

- confirm this on the aircraft radio.
- After a few seconds, the test result is displayed with the red visual indicator:
- One long flash indicates that the system is operational and that no error conditions were found.
- A series of short flashes indicates the test has failed.

Remark: The number of flashes gives an indication of the faulty parameter detected during the self-test.

Flashes	Meaning
3 + 1	Low Battery Voltage
3 + 2	Low RF Power
3 + 3	Faulty VCO Locking (Faulty Frequency)
3 + 4	No Identification Programmed

If self-test fails, contact the distributor as soon as possible. Unless a waiver is granted, flight should be cancelled.

924.5 PERFORMANCE

Not affected.

924.6 WEIGHT & CENTER OF GRAVITY

Refer to the equipment list in Section 6 of this Handbook.

924.7 SYSTEM DESCRIPTION

The ELT installation consists of the ELT unit fastened to the fuselage structure aft of the back seat, an antenna located on the main fuselage cover behind the cockpit, and a remote switch with a red visual indicator (LED) located on the instrument panel. The remote switch has the positions 'ON', 'ARMED' and 'RESET/TEST'. The switch on the ELT unit has the positions 'ARM', 'OFF' and 'ON'.

924.7.1 SWITCH OPERATION

In a crash, an acceleration activated crash sensor (G-switch) turns the ELT 'on' automatically. Activation is also accomplished by switching the cockpit mounted remote switch or the switch on the ELT to the 'ON' position. To deactivate the ELT switch the switch on the ELT unit to the 'OFF' position.

NOTE

With remote switch disconnected or during transport the ELT can still be manually activated using the local switch on the front of the ELT. Care should be taken when transporting or shipping the ELT not to move the switch or allow packing material to become lodged such as to toggle the switch.

It is possible to stop the ELT in case of unintentional activation:

- Switch to 'OFF'.

Regulations state that no transmission must be interrupted unless all means are used to contact and inform the Air Traffic Controller of this action.

NOTE

As 406 MHz transmission is effective 50 seconds after the ELT activation, if it is switched off within this delay, no further radio contact will be necessary.

924.8 HANDLING, SERVICING AND MAINTENANCE

Refer to the following applicable manufacturer instructions for further detailed information or when working on the Kannad 406 AF ELT:

- Installation and Operation Manual 406 AF-COMPACT ELT (P/N: DOC08038E Rev. 04)
- Initial Installation Manual 406 AF-INTEGRA ELT (P/N: DOC09081C Rev. 02)
- Operation Manual 406 AF-INTEGRA ELT (P/N: DOC09078C Rev. 02)

Manufacturer:

Kannad Aviation (McMurdo Group)
Orolia SAS
Z.I. des 5 Chemins BP 23
56520 Guidel (F)

924.8.1 PERIODIC INSPECTION

Depending if the ELT is opened or not, PART 145 or FAR 145 (or equivalent) may be required. Refer to local regulations.

924.8.2 BATTERY REPLACEMENT

Carried out by an accredited PART 145 or FAR 145 (or equivalent) maintenance station.

BATTERY REPLACEMENT REQUIREMENTS

Battery replacement is mandatory:

- after more than 1 hour of real transmission (cumulated duration);
- before or on the battery expiration date;
- after use in an emergency;
- after an inadvertent activation of unknown duration.

Only an original and approved battery pack included in battery KIT BAT200 (P/N S1840510-01) supplied by KANNAD must be installed. [SAFT-FRIWO, Lithium Manganese Dioxide, 2 x M20 (D-type) cells]

KANNAD refuses all responsibility and invalidates all warranty should other packs be installed.

Battery packs or KITs are available from any KANNAD distributor or dealer.

A list of distributors is available on <http://www.kannad.com>

Left blank intentionally